

SIRUBA®

零件圖

PARTS LIST

■ D007R(B)

From the library of: Diamond Needle Corp

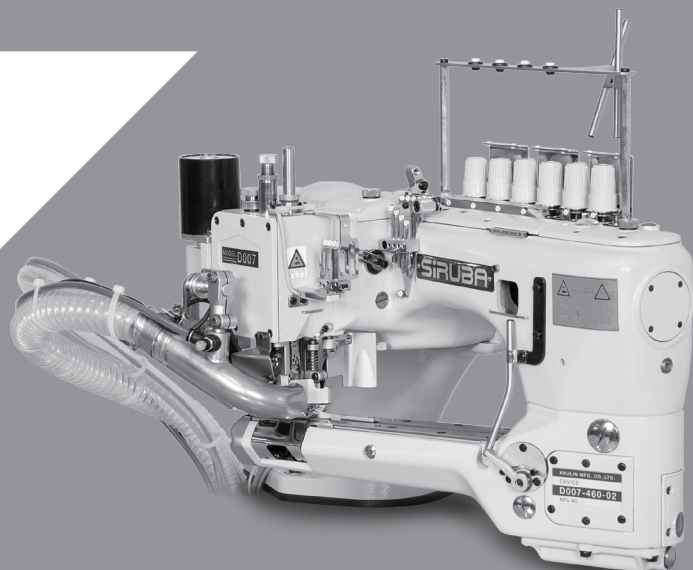

CE

CONTENTS 目次

頁數

MISCELLANEOUS COVERS (1)	
機殼機構 (1).....	1
MISCELLANEOUS COVERS (2)	
機殼機構 (2).....	2
MISCELLANEOUS THREAD EYELETS-4NEEDLE	
過線機構-四針六線.....	3
MISCELLANEOUS BUSHINGS	
套管機構.....	4
MAIN SHAFT DRIVING MECHANISM	
上主軸與針棒機構.....	5
ONE SIDE CUT PRESSER FOOT MECHANISM	
單切押腳與押腳驅動機構.....	6
UPPER KNIFE , CARRIER AND HOOK DRIVING MECHANISM	
上切刀及上勾針驅動機構.....	7
LOOPER DRIVING MECHANISM	
下勾針驅動機構.....	8
FEED DRIVING MECHANISM	
送料具驅動機構.....	9
FEED DRIVING CONTROL MECHANISM	
送料具調節機構.....	10
LUBRICATING MECHANISM	
給油機構.....	11
DEIRCTLY DRIVING TYPE MINI-SERVO MOTOR C. SET	
伺服馬達機構.....	12
SUPPORTING BLOCK MECHANISM	
車台固定座機構.....	14
" AW1" DEVICE C. SET (SELECT DEVICE)	
外接式吸布屑組-AW1 (選擇配備).....	15
" AW2" DEVICE C. SET (SELECT DEVICE)	
密封式(箱型)吸布屑組-AW2 (選擇配備).....	16
THREAD STAND	
線架組.....	17

CONTENTS 目次

頁數

DOBLE SIDE CUT PRESSER FOOT MECHANISM	
雙切押腳機構.....	18
ATTACHMENT BOX	
附件盒.....	19
ACCESSORIES	
附件箱.....	20
SELECT DEVICE (02-T1)	
選擇配備(02-T1)-織帶.....	21
SELECT DEVICE (01-T2)	
選擇配備(01-T2)-貼條.....	22
SELECT DEVICE (S)	
選擇配備(S)-襪子.....	23
SELECT DEVICE (01-DS)-452.460	
選擇配備(01-DS)-452.460潛水衣.....	24
SELECT DEVICE(02R)	
選擇配備(02R)-弧狀車縫.....	25
SELECT DEVICE(02H)	
選擇配備(02H)-包縫過骨/特厚刷毛.....	26
SELECT DEVICE(02RH)	
選擇配備(02RH)-弧狀車縫包縫過骨.....	27
SELECT DEVICE (02-T2)	
選擇配備(02-T2) -貼條.....	28
SELECT DEVICE (FEED DOG)	
特殊勾齒(膠齒、細齒).....	29
SELECT DEVICE (EK PRESSER FOOT)	
選擇配備(EK)-押腳.....	31
SELECT DEVICE (MISCELLANEOUS THREAD EYELETS-5NEEDLE)	
選擇配備(過線機構-五針七線).....	33
SELECT DEVICE (01-DS)-470.480	
選擇配備(01-DS)-470.480潛水衣.....	34
SELECT DEVICE (02-4LXX)	
選擇配備(02-4LXX)-段差厚料.....	35
SELECT DEVICE (EK)	
選擇配備(EK)-自動切線.....	36

CONTENTS 目次

頁數

" AW9L、AW9S" DEVICE C. SET (SELECT DEVICE)	
EK集塵裝置-AW9L、AW9S(選擇配備).....	37
SELECT DEVICE(01-T3)	
選擇配備(01-T3)-織帶裝飾.....	38
SELECT DEVICE(T4)	
選擇配備(T4)-雙貼條.....	39
" AW10 " DEVICE C. SET (SELECT DEVICE)	
EK集塵裝置-AW10(選擇配備).....	41
" AW11、AW11S " DEVICE C. SET (SELECT DEVICE)	
筒型吸布屑組-AW11L、AW11S(選擇配備).....	42
SELECT DEVICE(01-T5)	
選擇配備(01-T5)-滾條裝飾車縫.....	43
SELECT DEVICE(02-T2A)	
選擇配備(02-T2A)-貼條.....	44
SELECT DEVICE(MOTOR SUPPORT)	
底座增高選配件.....	45
TABLE	
桌板圖.....
STITCH LENGTH SPECIFICATION	
針距規格表.....	附件1

※零件本使用說明:

- 1、當零件用虛線表示，零件編號為 X-X 時，表示非該頁面零件，且僅用於輔助說明組裝位置；
 例如：7-14 為第7頁、零件序號14的零件。

- 2、當零件用實線表示，零件編號為 X-X 時，表示該頁需使用此零件，但已編制在其他頁，為避免銷售人員與客戶有遺漏而繪製；例如：36-32為第36頁、零件序號32的零件。

- 3、當組件中有包含其他頁的零件時，零件用實線表示，零件編號為 X-X
 例如：4-5 為第4頁、零件序號15的零件。

- 4、組件中的零件用虛線表示一律代表不包含該零件，實線則為包含。

1

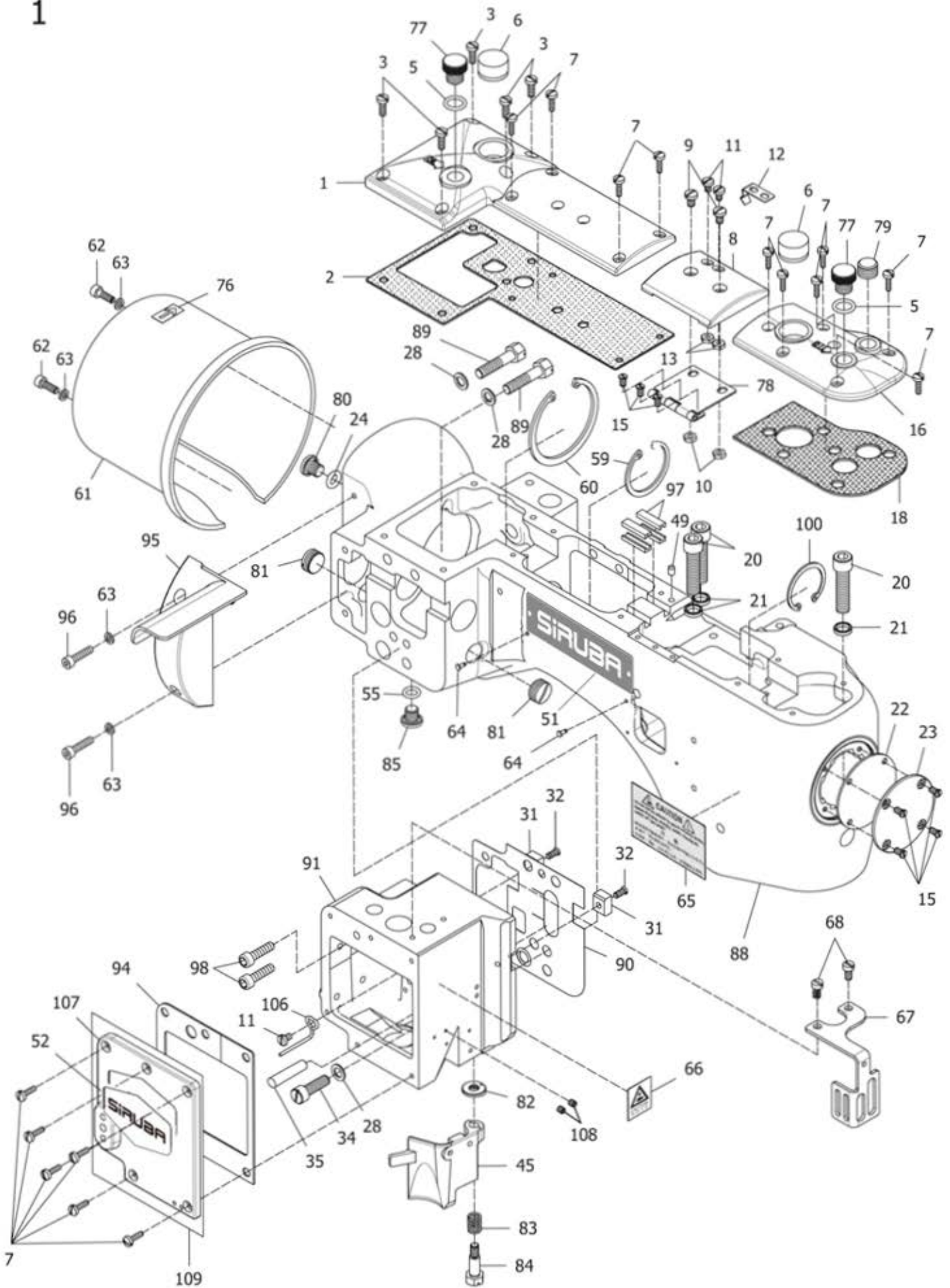

MISCELLANEOUS COVERS (1)**機殼機構 (1)****1**

Ref.	Parts			Amt.
<u>No.</u>	<u>No.</u>	<u>Description</u>	<u>品 名</u>	<u>Req.</u>
1	07400101	Crank Chamber Cover.....	曲軸室上蓋.....	1
2	07400102	Crank Chamber Cover Gasket.....	曲軸室墊片.....	1
3	07400103	Screw(11/64-40X10.5).....	螺絲.....	5
5	07400105	O-Ring.....	O型橡膠環.....	2
6	07400106	Oil Sight Top Window.....	上油鏡.....	2
7	07400107	Screw (9/64-40X10.8).....	螺絲.....	16
8	07400108	Top Cover (Middle).....	上蓋(中).....	1
9	07400109	Screw (11/64-40X6.5).....	螺絲.....	2
10	07400110	Nut.....	螺帽.....	2
11	07400111	Screw (9/64-40X5.6).....	螺絲.....	3
12	07400112	Top Cover (Middle) Spring.....	上蓋(中)彈簧.....	1
13	07400113	Nut.....	螺帽.....	2
15	07400115	Screw (9/64-40X6).....	螺絲.....	7
16	07400116	Top Cover (Front).....	上蓋(前).....	1
18	07400118	Top Cover (Front) Gasket.....	上蓋墊片(前).....	1
20	07400120	Screw (5/16-24X32).....	螺絲.....	3
21	07400121	Washer.....	墊片.....	3
22	07400122	Machine Frame End Cover Gasket.....	防油墊片.....	1
23	07400123	Machine Frame End Cover.....	前方圓蓋.....	1
24	07400124	O-Ring.....	O型橡膠環.....	1
28	07400128	Washer.....	墊片.....	3
31	07400131	Sewing Head Key.....	車台四角固定銷.....	2
32	07400132	Screw (9/64-40X8).....	螺絲.....	2
34	07400134	Screw (1/4-28X20).....	螺絲.....	1
35	07400135	Pin.....	插銷.....	1
45	07400145	Frame Chip Guard.....	導布蓋.....	1
49	07400149	Oil Seal Plug.....	止油塞.....	1
51	07400151	Emblem.....	銘牌.....	1
52	07400152	Emblem.....	銘牌.....	1
55	07400155	O-Ring.....	O型橡膠環.....	1
59	07400159	Retaining Ring.....	扣環.....	1
60	07400160	Retaining Ring.....	扣環.....	1
61	07400161	Motor Cover.....	馬達護蓋.....	1
62	07870623	Screw (M4-0.7X12).....	螺絲.....	2

1

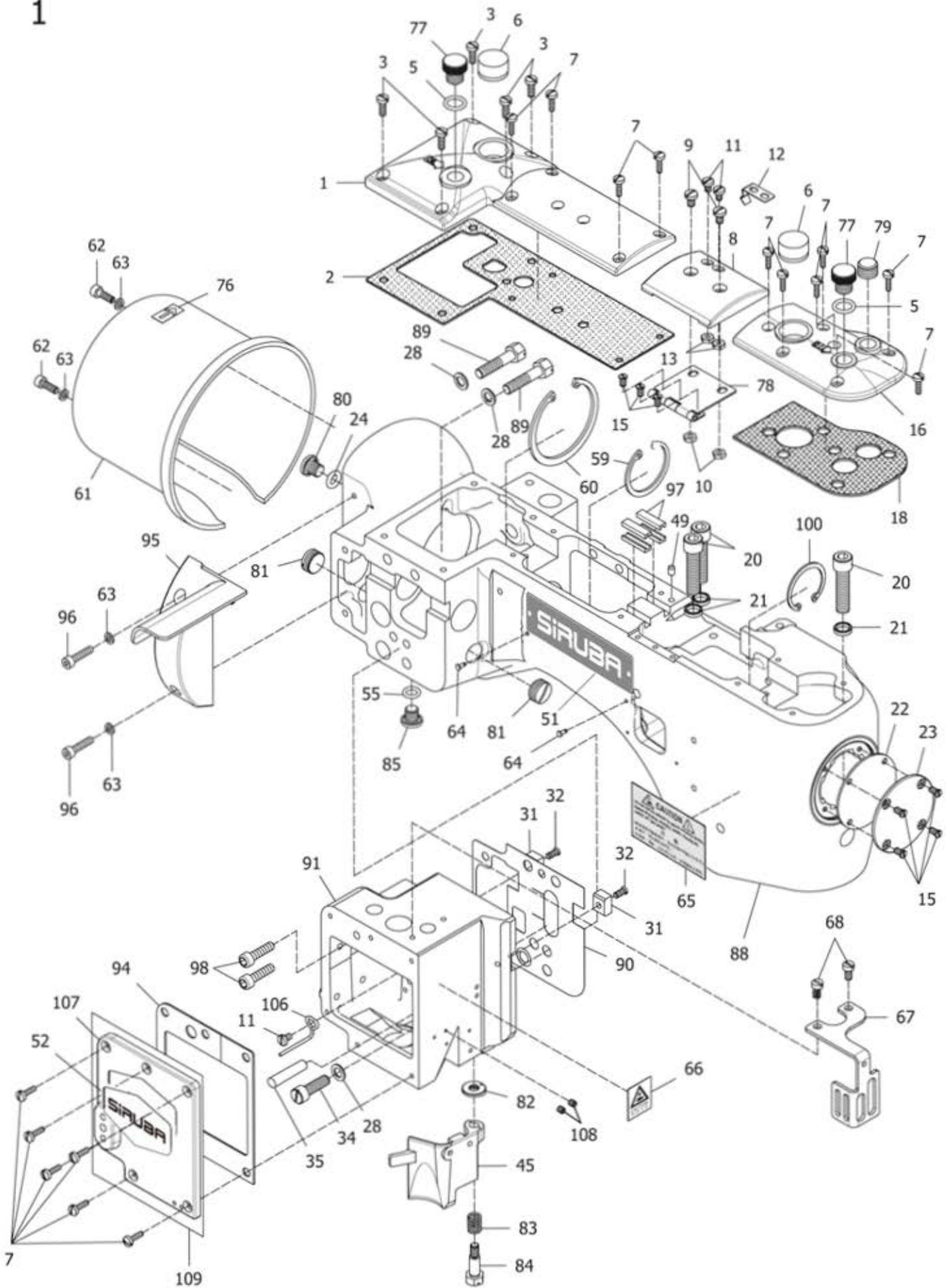

MISCELLANEOUS COVERS (1)**機殼機構 (1)****1**

Ref.	Parts			Amt.
<u>No.</u>	<u>No.</u>	<u>Description</u>	<u>品 名</u>	<u>Req.</u>
63	07870650	Washer.....	墊片.....	4
64	07400164	Rivet.....	鉚釘.....	2
65	07400165	Warning Sticker.....	警告貼紙.....	1
66	07400166	Warning Sticker.....	警告貼紙.....	1
67A	07400167A	Cover.....	打線器護蓋.....	1
68	07400168	Screw (M4-0.7X8).....	螺絲.....	2
76	07400176	Direction Sticker.....	箭頭貼紙.....	1
77	07400177	Screw(M12-1.75X9).....	螺絲.....	2
78	07400178	Top Cover (Middle) Hinge.....	上翻蓋.....	1
79	07400179	Plug Screw (M12-1.75X7).....	止油螺絲.....	1
80	07400180	Screw (3/8-24X8).....	螺絲.....	1
81	07400181	Plug Screw (M14-1X4).....	止油螺絲.....	2
82	07400182	Frame Chip Guard Washer.....	導布蓋固定墊片.....	1
83	07400183	Frame Chip Guard Spring.....	導布蓋彈簧.....	1
84	07400184	Screw (M5-0.8X8.5).....	螺絲.....	1
85	07400185	Screw (M8-1.25X8).....	螺絲.....	1
88	07400188	Machine Frame.....	機殼.....	1
89	07400189	Screw (1/4-28X17.5).....	螺絲.....	2
90	07400190	Sewing Head Oil Defense.....	車台結合防油擋板.....	1
91	07400191	Sewing Head.....	車頭.....	1
94	07400194	Seal Gasket.....	止油墊片.....	1
95	07400195	Cover.....	馬達側蓋.....	1
96	07870724	Screw (M4-0.7X18).....	螺絲.....	2
97	07400197	Rubber Block.....	橡膠塊.....	4
98	07801319	Screw (M5-0.8X20).....	螺絲.....	2
100	074001100	Retaining Ring.....	扣環.....	1
106	074001106	Oil Guide Wire.....	導油棉線固定架.....	1
107	074001107	Sewing Head Cover(Left).....	車頭蓋(左).....	1
108	074001108	Screw (9/64-40X4).....	螺絲.....	2
109	074001109	Sewing Head Cover(Left) C.Set.....	車頭蓋(左)組.....	1

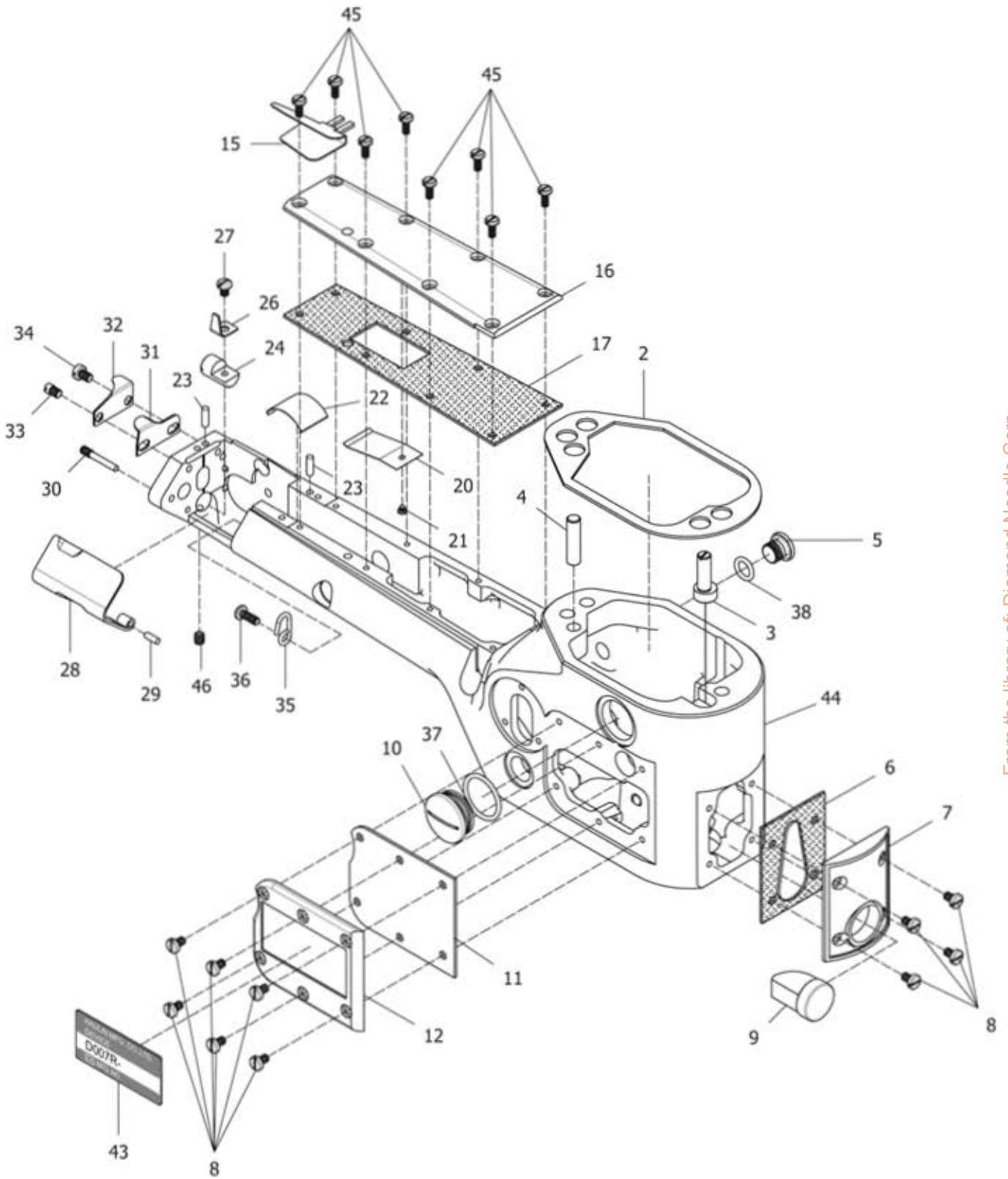

MISCELLANEOUS COVERS (2)**機殼機構 (2)****2**

Ref.	Parts			Amt.
<u>No.</u>	<u>No.</u>	<u>Description</u>	<u>品 名</u>	<u>Req.</u>
2	07400202	Sewing Head Oil Defense.....	防油擋板.....	1
3	07400203	Alignment Pin.....	調節插銷.....	1
4	07400204	Knock Pin.....	頂出銷.....	1
5	07400205	Screw(3/8-24X8).....	螺絲.....	1
6	07400206	Seal Gasket.....	止油墊片.....	1
7	07400207	Cylinder Frame Cover (Front).....	前蓋.....	1
8	07400208	Screw (9/64-40X8).....	螺絲.....	10
9	07400209	Oil Gauge.....	油錶.....	1
10	07400210	Screw (M22-1.5X7).....	螺絲.....	1
11	07400211	Seal Gasket.....	止油墊片.....	1
12	07400212	Cylinder Frame Cover (Left).....	左蓋.....	1
15	07400215	Folder.....	導布器.....	1
16	07400216	Cylinder Frame Cover (Upper).....	上蓋.....	1
17	07400217	Seal Gasket.....	止油墊片.....	1
20	07400220	Dust Defender (Upper).....	防塵蓋(上).....	1
21	07400221	Screw (3/32-56X1.8).....	螺絲.....	1
22	07400222	Dust Defender (Lower).....	防塵蓋(下).....	1
23	07400223	Pin.....	插銷.....	2
24	07400224	Looper Cover Spring Support.....	彈簧片座.....	1
26	07400226	Looper Cover Spring.....	下勾針蓋彈簧片.....	1
27	07400227	Screw (9/64-40X5).....	螺絲.....	1
28	07400228	Looper Cover.....	下勾針蓋.....	1
29	07400229	Pin.....	插銷.....	1
30	07400230	Screw (9/64-40X5.7).....	螺絲.....	1
31	07400231	Chain-off Cutting Knife.....	割線刀.....	1
32	07400232	Chain-off Cutting Knife Guard.....	割線刀擋.....	1
33	07400233	Screw (M4-0.7X4.5).....	螺絲.....	1
34	07400234	Screw (M4-0.7X5.7).....	螺絲.....	1
35	07400235	Looper Thread Guide Wire.....	過線圈.....	1
36	07400236	Screw (9/64-40X10).....	螺絲.....	1
37	07400237	O-Ring.....	O型橡膠環.....	1
38	07400238	O-Ring.....	O型橡膠環.....	1
43	07400243	Model Plate.....	型號銘牌.....	1
44	07400244	Cylinder Frame.....	圓筒部機殼.....	1
45	07400245	Screw (1/8-44X10).....	螺絲.....	8
46	07400246	Screw (11/64-40X6).....	螺絲.....	1

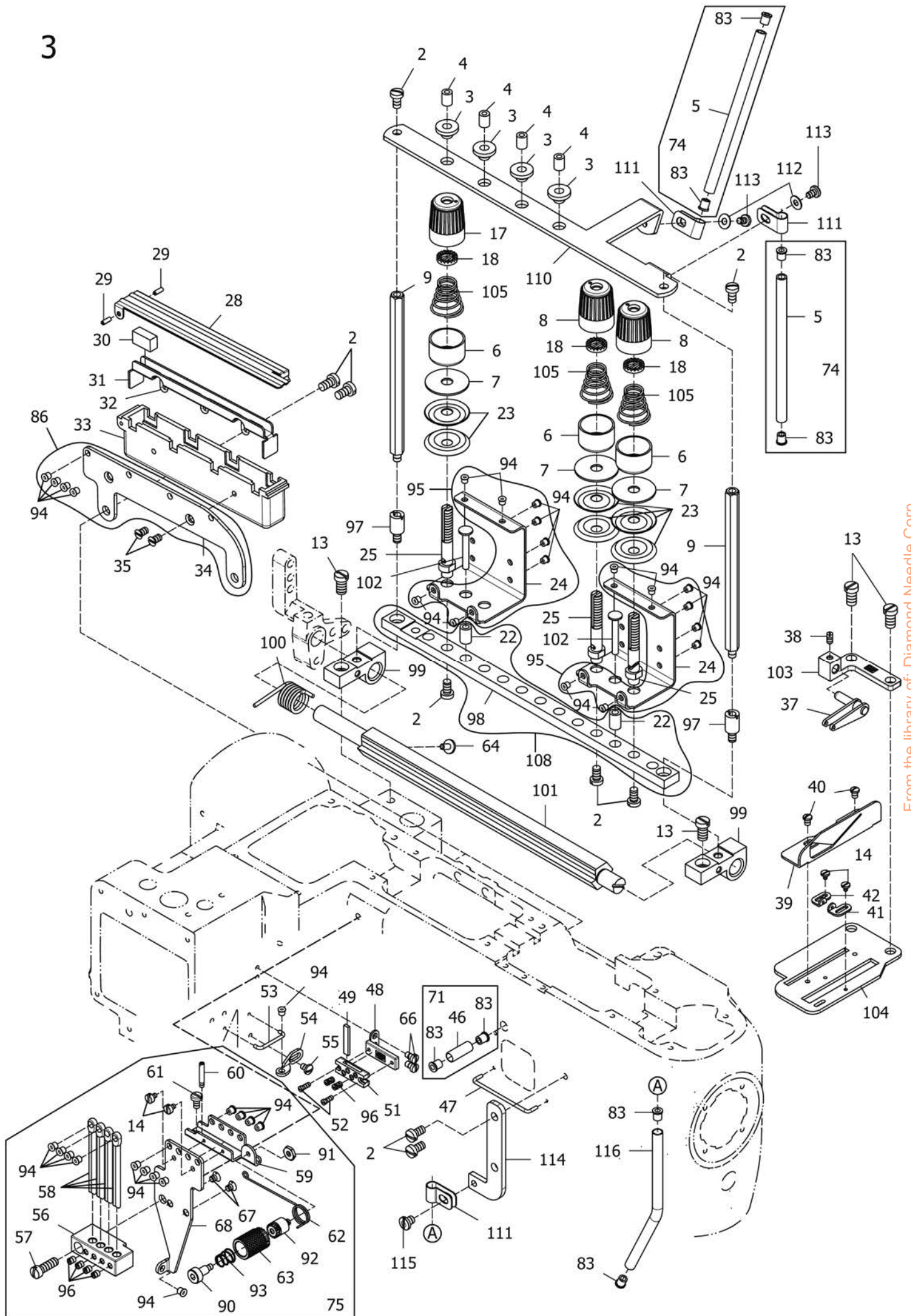

MISCELLANEOUS THREAD EYELETS-4NEEDLE

過線機構-四針六線

3

Ref.	Parts			Amt.
<u>No.</u>	<u>No.</u>	<u>Description</u>	<u>品 名</u>	<u>Req.</u>
2	07400302	Screw (11/64-40X7.8).....	螺絲.....	12
3	07400303	Thread Eyelet Bushing.....	過線孔套圈.....	4
4	07400304	Thread Eyelet.....	過線孔.....	4
5	07870321	Thread Pipe (Long).....	過線管(長).....	2
6	07870306	Spring Retainer.....	彈簧固定座.....	6
7	07870307	Felt.....	氈墊.....	6
8	07870343	Spring Cap.....	彈簧調整鈕.....	2
9	07400309	Thread Guide Plate Support.....	線架板支撐棒.....	2
13	07400313	Screw (7/32-32X10).....	螺絲.....	4
14	07400314	Screw (3/32-56X3.1).....	螺絲.....	4
17	07870301	Spring Cap.....	彈簧調整鈕.....	4
18A	07870302A	Tension Spring Disc Support.....	張力彈簧調整圓盤.....	6
22	07400322	Tension Release Pin Bushing.....	張力釋放插銷套管.....	7
23	07400323	Thread Tension Disc.....	張力調整盤.....	12
24A	07400324A	Thread Tension Disc Eyelet.....	張力調整過線架.....	3
25A	07400325A	Tension Post.....	張力彈簧支柱.....	6
28	07400328	Oil Cup Lip.....	矽油儲存槽蓋.....	1
29	07400329	Hinge Pin.....	鉸鏈插銷.....	2
30	07400330	SP Felt.....	SP吸油氈.....	4
31	07400331	SP Felt Stay.....	SP吸油氈支柱.....	1
32	07400332	Oil Wick.....	油芯.....	1
33	07400333	SP Container.....	矽油儲存槽.....	1
34A	07400334A	SP Container Support.....	矽油儲存槽固定座.....	1
35	07400335	Screw (9/64-40X4.6).....	螺絲.....	2
37	07400337	Thread Take-up Eyelet.....	提線桿.....	1
38	07400338	Screw (1/8-44X5).....	螺絲.....	1
39	07400339	Looper Thread Take-up Guide.....	下勾針提線桿護架.....	1
40	07870366	Screw (1/8-44X4.3).....	螺絲.....	2
41	07400341	Looper Thread Take-up Eyelet(Front).....	下勾針提線桿.....	1
42	07400342	Looper Thread Take-up Eyelet(Rear).....	下勾針提線桿.....	1

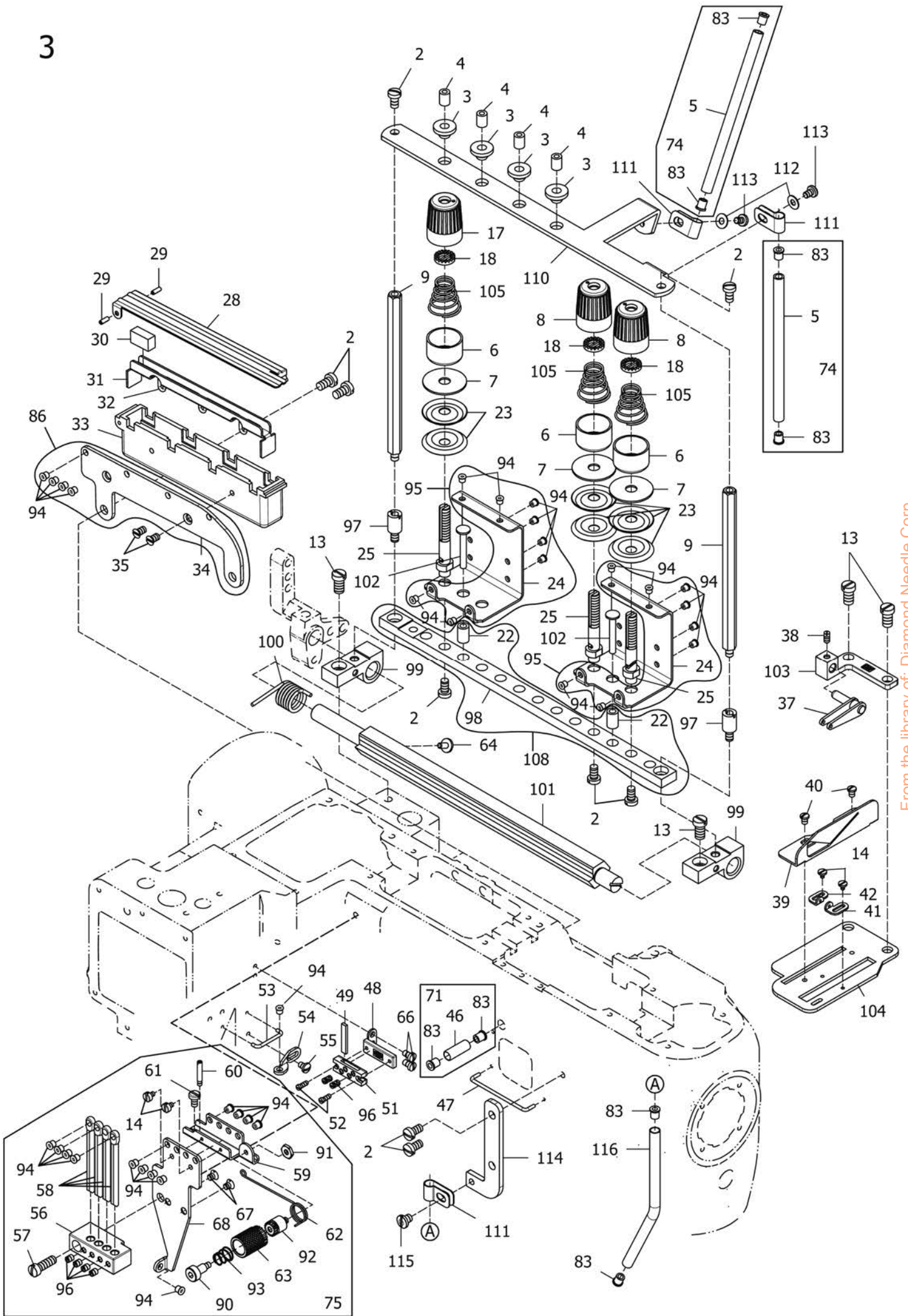

MISCELLANEOUS THREAD EYELETS-4NEEDLE

過線機構-四針六線

3

Ref.	Parts			Amt.
<u>No.</u>	<u>No.</u>	<u>Description</u>	<u>品 名</u>	<u>Req.</u>
46	07400346	Top Cover Thread Pipe.....	上飾線過線導管.....	1
47	07400347	Looper Thread Guide Wire (Upper).....	下勾針線導架金屬線.....	1
48A	07400348A	Needle Thread Strike-off Pin Holder Bracket...	打線片固定架.....	1
49A	07400349A	Needle Thread Strike-off Pin.....	打線片.....	4
51A	07400351A	Needle Thread Strike-off Pin Holder.....	打線片固定座.....	1
52	07400352	Screw (3/32-56X6.2).....	螺絲.....	2
53	07400353	Needle Thread Guide Wire.....	針線導架金屬線.....	1
54A	07400354A	Head Cover Thread Eyelet.....	車台前蓋過線孔.....	1
55	07400355	Screw (1/8-44X4.4).....	螺絲.....	1
56A	07400356A	Needle Thread Eyelet Holder.....	針線過線棒座.....	1
57	07400357	Screw (11/64-40X13).....	螺絲.....	1
58A	07870330B	Needle Thread Eyelet.....	針線過線棒.....	4
59A	07400359A	Stitch Unlocker Mounting Bracket.....	過線架.....	1
60	07400360	Screw (M2.3-0.4X3).....	螺絲.....	1
61	07400361	Screw (1/8-44X5.9).....	螺絲.....	1
62	07400362	Stitch Unlocking Spring.....	過線彈簧.....	1
63	07400363	Stitch Unlocking Spring Holder.....	過線彈簧調節鈕.....	1
64	07400364	Screw (1/8-44X6.4).....	螺絲.....	1
66	07400366	Screw (1/8-44X5.6).....	螺絲.....	2
67	07400367	Screw (1/8-44X2.7).....	螺絲.....	2
68A	07400368A	Stitch Unlocking Holder.....	過線座.....	1
71	07400371	Top Cover Thread Pipe C.Set.....	上飾線過線導管組.....	1
74	07400374	Thread Pipe C.Set (Long).....	過線管組(長).....	2
75A	07400375A	Needle Thread Eyelet C.Set.....	針線過線棒組.....	1
83	07870363	Thread Eyelet.....	過線陶瓷(深灰).....	8
86	07400386	SP Container Support C.Set.....	矽油儲存槽固定座組.....	1
90	07400390	Screw (M3-0.5X4).....	螺絲.....	1
91	07400391	Nut.....	螺帽.....	1
92	07400392	Screw (1/8-44X3.8).....	螺絲.....	1

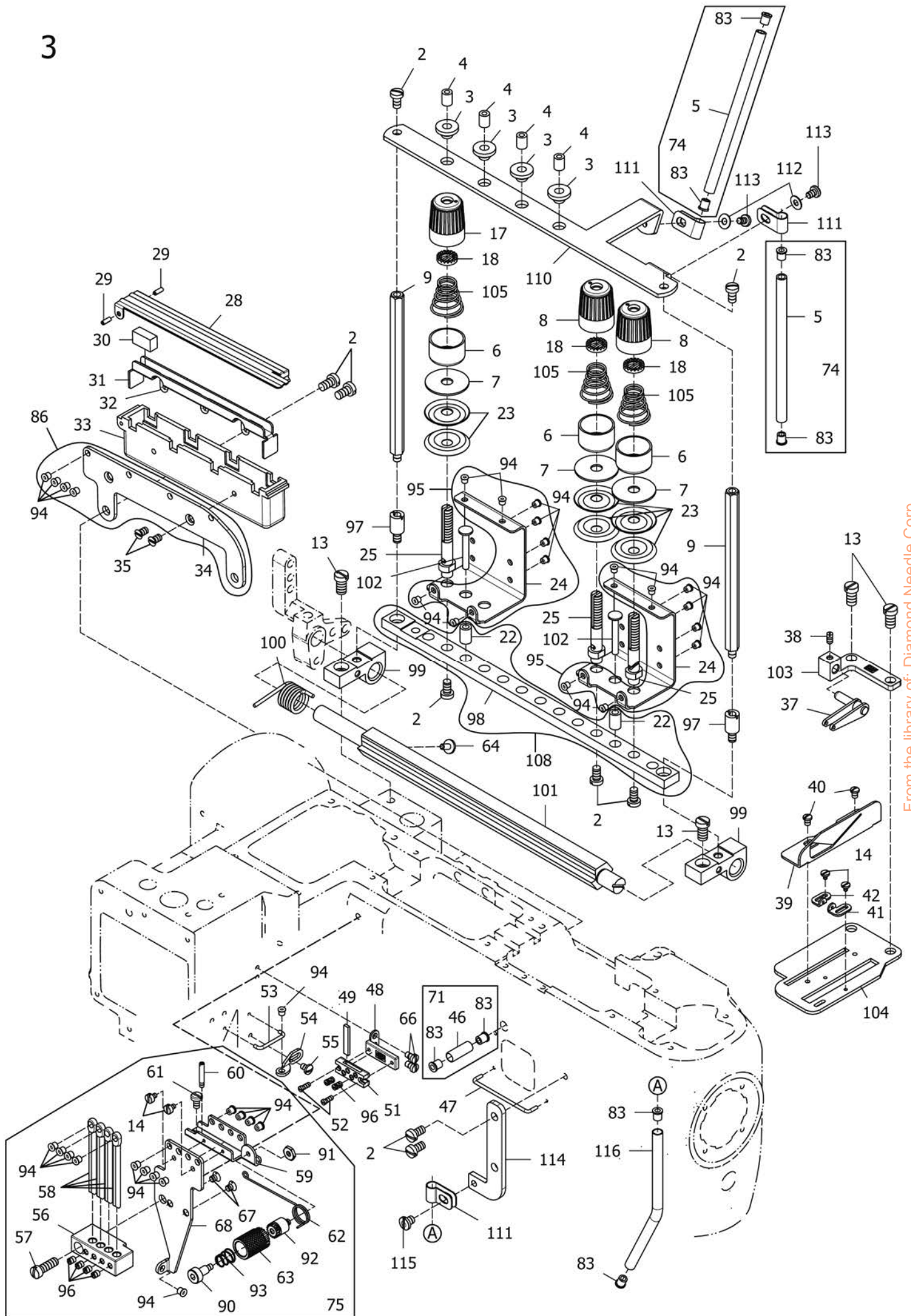

MISCELLANEOUS THREAD EYELETS-4NEEDLE

過線機構-四針六線

3

Ref.	Parts			Amt.
<u>No.</u>	<u>No.</u>	<u>Description</u>	<u>品 名</u>	<u>Req.</u>
93	07400393	Stitch Unlocking Spring.....	過線彈簧.....	1
94	07870365	Thread Eyelet.....	過線陶瓷(白).....	42
95	07400395	Thread Tension Disc Eyelet C.Set.....	張力調整過線架組.....	3
96	07870319	Screw (1/8-44X2.6).....	螺絲.....	8
97	07400397	Screw (11/64-40X7).....	螺絲.....	2
98	07400398	Thread Tension Support.....	上線張力固定座.....	1
99	07400399	Thread Tension Support Bracket.....	上線張力固定座支架.....	2
100	074003100	Tension Release Shaft Spring.....	張力釋放軸彈簧.....	1
101	074003101	Tension Release Shaft.....	張力釋放軸.....	1
102	074003102	Tension Release Pin.....	張力釋放插銷.....	7
103	074003103	Thread Take-up Eyelet Holder.....	提線桿托架.....	1
104	074003104	Eyelet Supporting Plate.....	提線桿固定板.....	1
105	07870372	Needle Thread Tension Spring.....	針線張力彈簧.....	4
108	074003108	Thread Tension Support C.Set.....	上線張力固定座組.....	1
109	074003109	Thread Guide C.Set (4 Needle).....	線架組(四針六線).....	0
110	074003110	Thread Guide Plate.....	線架板.....	1
111	074003111	Tube Clip.....	管夾.....	3
112	07400139	Washer.....	墊片.....	2
113	07400227	Screw (9/64-40X5).....	螺絲.....	2
114	07410334	Looper Thread Guide.....	下勾針線導架.....	1
115	07410345	Screw (11/64-40X5).....	螺絲.....	1
116	074003116	Thread Pipe.....	過線管.....	1

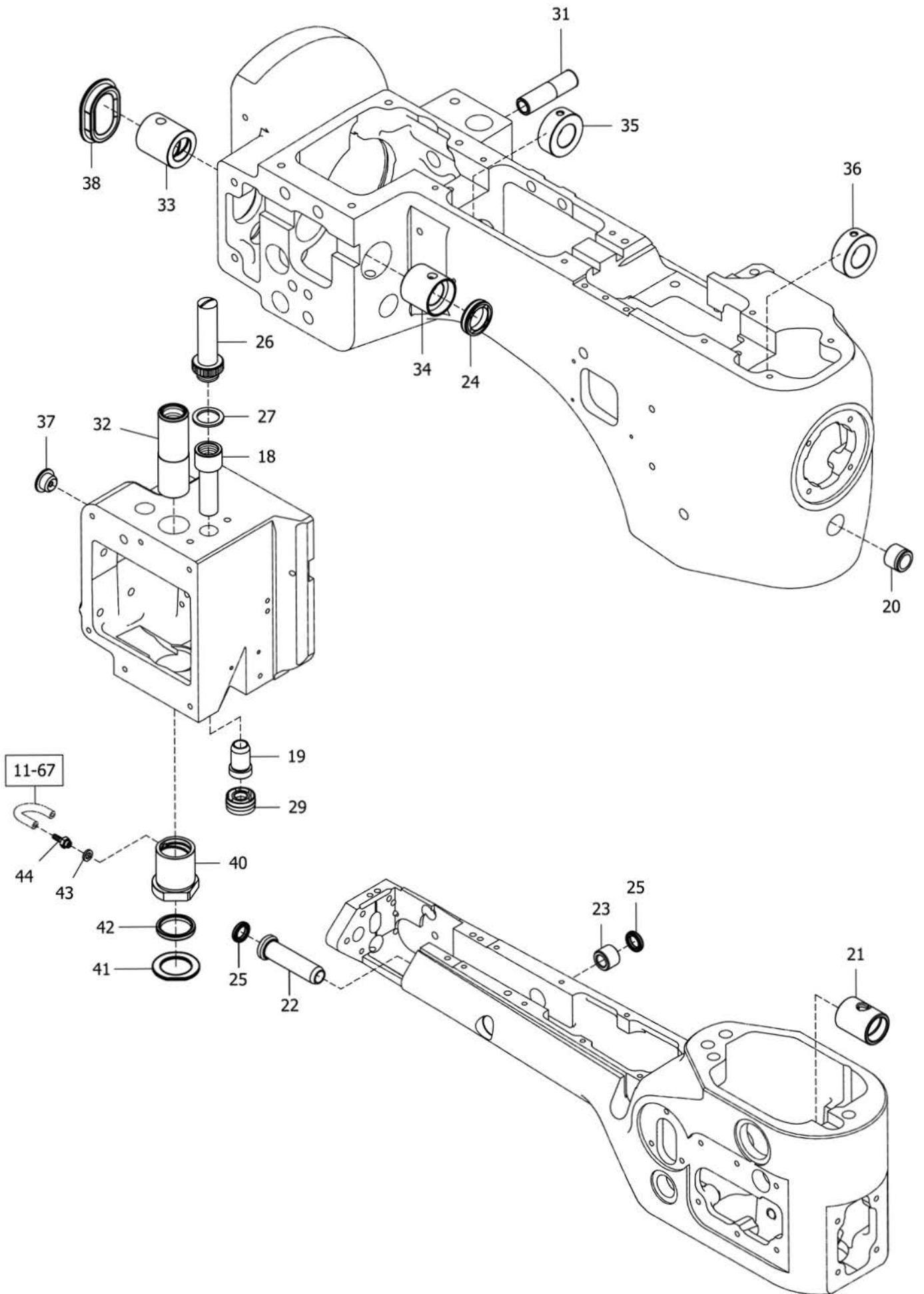

MISCELLANEOUS BUSHINGS**套管機構****4**

Ref.	Parts			Amt.
<u>No.</u>	<u>No.</u>	<u>Description</u>	<u>品 名</u>	<u>Req.</u>
18	07400418	Needle Bar Bushing(Upper).....	針柱套管(上).....	1
19	07400419	Needle Bar Bushing(Lower).....	針柱套管(下).....	1
20	07400420	Looper Driving Lever Shaft Bushing.....	下勾針驅動軸套管.....	1
21	07400421	Looper Rocker Shaft Bushing (Front).....	下勾針搖桿軸套管(前).....	1
22	07400422	Looper Rocker Shaft Bushing (Rear).....	下勾針搖桿軸套管(後).....	1
23	07400423	Feed Bar Eccentric Pin Bushing.....	送料具偏心銷套管.....	1
24	07400424	Oil Seal.....	油封.....	1
25	07400425	Oil Seal.....	油封.....	2
26	07400426	Needle Bar Bushing(Upper)Lid.....	針柱套管(上)蓋.....	1
27	07400427	Gasket.....	墊片.....	1
29	07400429	Oil Seal.....	油封.....	1
31	07400431	Presser Foot Lifter Stop Plunger Bushing.....	擡押腳軸套管.....	1
32	07400432	Presser Bar Bushing.....	押腳套管.....	1
33	07400433	Knife Driving Lever Bushing (Rear).....	傳動刀軸銅套(後).....	1
34	07400434	Knife Driving Lever Bushing (Front).....	傳動刀軸銅套(前).....	1
35	07400435	Main Shaft Bushing (Rear).....	主軸套管(後).....	1
36	07400436	Main Shaft Bushing (Front).....	主軸套管(前).....	1
37	07400437	Seal Plug.....	止油膠塞.....	1
38	07400438	Seal Plug.....	止油膠塞.....	1
40	07400440	Thread Carrier and Hook Sleeve Bushing.....	上飾線銅套.....	1
41	07400441	Bushing Ring.....	墊片.....	1
42	07400442	Oil Seal.....	油封.....	1
43	07400443	Washer.....	墊片.....	1
44	07400444	Lubrication Connector.....	潤滑接頭.....	1

5

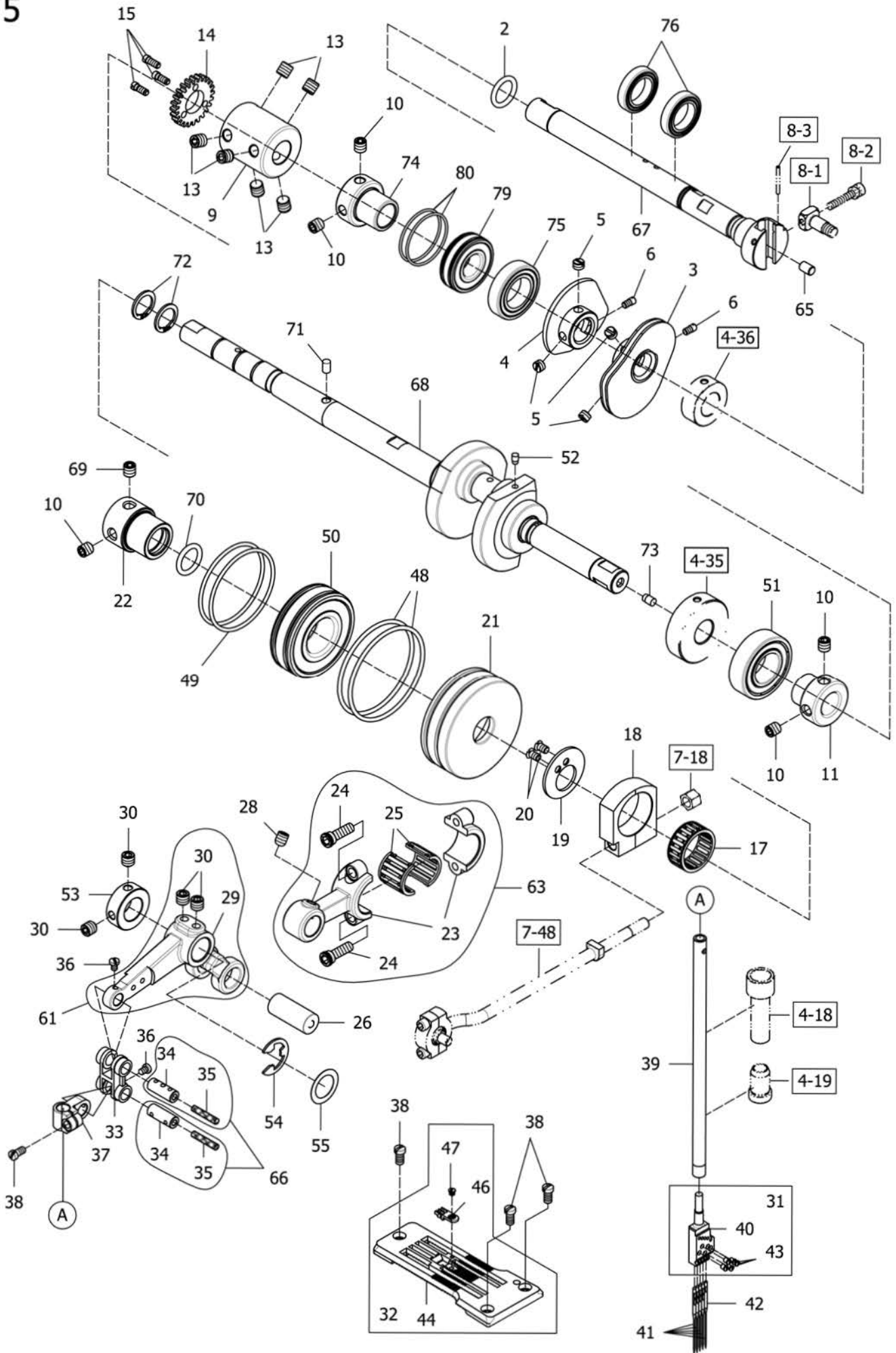

MAIN SHAFT DRIVING MECHANISM**上主軸與針棒機構****5**

Ref.	Parts			Amt.
No.	No.	Description	品名	Req.
2	07400502	O-ring.....	O型橡膠環.....	1
3	07400503	Looper Thread Take-Up.....	底線提線凸輪.....	1
4	07400504	Top Cover Thread Take-Up.....	上飾線提線凸輪.....	1
5	07400505	Screw (7/32-32X3.6).....	螺絲.....	4
6	07400506	Positioning Screw (1/8-44X4).....	螺絲.....	2
9	07400509	Front and Rear Connecting Sleeve.....	前後軸連接襯套.....	1
10	07400510	Screw (M6-1X6).....	螺絲.....	5
11	07400511	Collar.....	固定軸環.....	1
13	07400513	Screw (1/4-28X6.3).....	螺絲.....	6
14	07400514	Pump Driving Gear.....	油泵驅動齒輪.....	1
15	07400515	Screw (1/8-44X6).....	螺絲.....	3
17	07400517	Needle Bearing.....	滾針軸承.....	1
18	07400518	Thread Carrier and Hook Driving Rod (Right).	上飾線驅動培林外殼.....	1
19	07400519A	Needle Bearing Retaining Plate.....	滾針軸承扣板.....	1
20	07400520	Screw (9/64-40X6).....	螺絲.....	2
21	07400521A	Bearing Sleeve.....	培林襯套.....	1
22	07400522A	Motor Connecting Rod Sleeve.....	馬達連接襯套.....	1
23	07400523	Needle Bar Lever Connecting Rod.....	針柱槓桿連桿.....	1
24	07400524	Screw (3/16-32X14).....	螺絲.....	2
25	07400525	Needle Bearing.....	滾針軸承.....	2
26	07400526	Needle Bar Lever Connecting Rod Pin.....	針柱槓桿連桿插銷.....	1
28	07400528	Screw (7/32-32X4.5).....	螺絲.....	1
29	07400529	Needle Bar Lever.....	針柱槓桿.....	1
30	07400530	Screw (M5-0.8X5).....	螺絲.....	4
31	★	Needle Clamp C.Set.....	針鑷組.....	1
32	★	Stitch Plate C.Set.....	針板組.....	1
33	07400533	Needle Bar Connecting Link.....	針柱連桿.....	1
34	07400534	Needle Bar Connecting Link Pin.....	針柱連桿插銷.....	2
35	07871259	Oil Wick.....	吸油繩.....	2
36	07400536	Screw (1/8-44X5).....	螺絲.....	2
37	07400537	Needle Bar Connecting Bracket.....	針柱連結架.....	1
38	07400538	Screw (9/64-40X6.4).....	螺絲.....	4
39	07400539	Needle Bar.....	針柱.....	1
40	★	Needle Clamp.....	針鑷.....	1
41	★	Needle.....	機針.....	4

★ 請參照附件1【針距規格表】

5

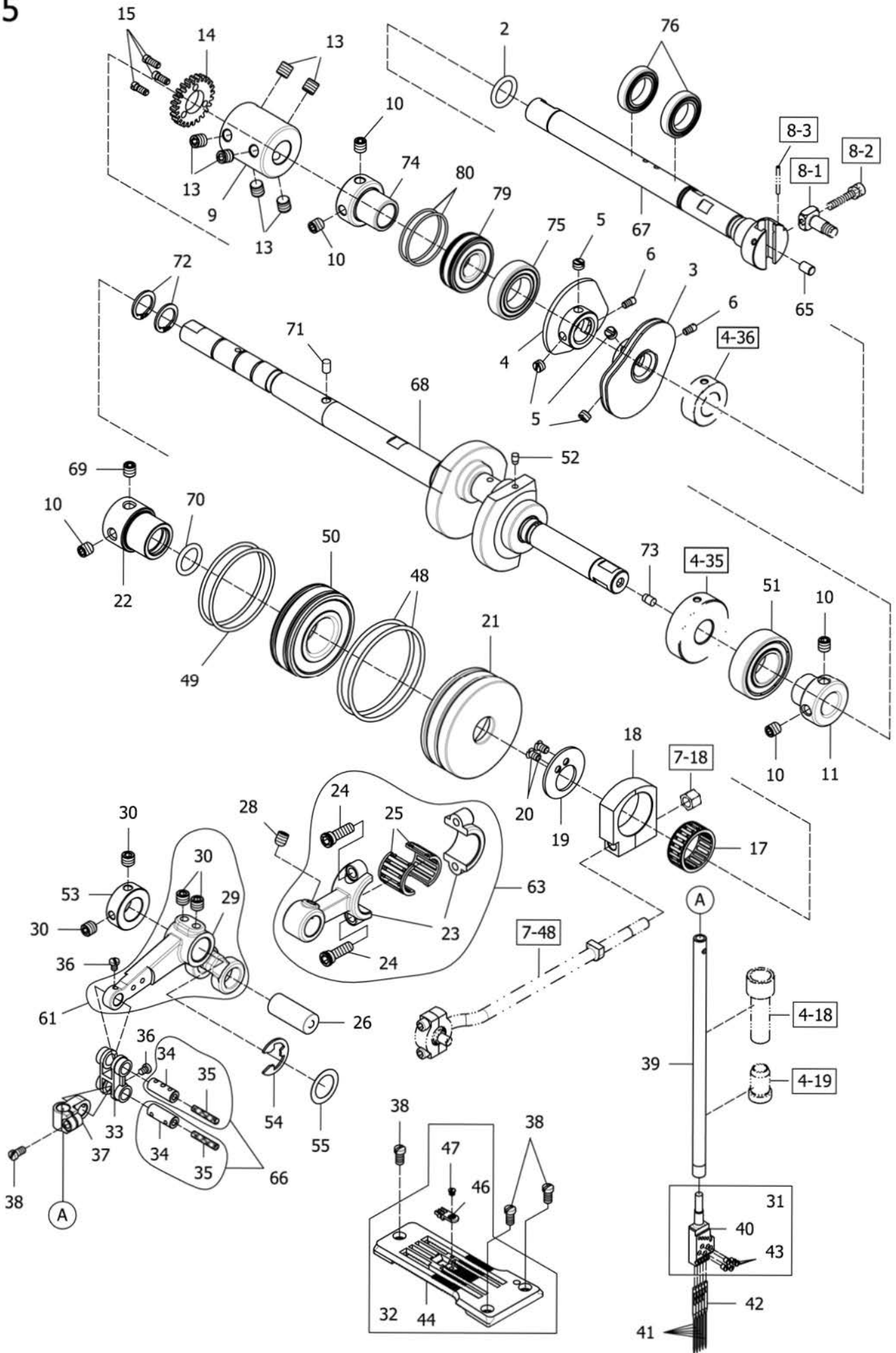

MAIN SHAFT DRIVING MECHANISM

上主軸與針棒機構

5

Ref.	Parts			Amt.
<u>No.</u>	<u>No.</u>	<u>Description</u>	<u>品 名</u>	<u>Req.</u>
42	★	Retainer.....	假針.....	1
43	07400543	Screw (3/32-56X2.5).....	螺絲.....	5
44	★	Stitch Plate.....	單切針板.....	1
46	★	Stitch Plate Tongue.....	針板舌.....	1
47	07400547	Screw (3/32-56X2).....	螺絲.....	1
48	07400548	O-ring.....	O型橡膠環.....	2
49	07400549	O-ring.....	O型橡膠環.....	2
50	07400550	Ball Bearing.....	滾珠軸承.....	1
51	07400551	Ball Bearing.....	滾珠軸承.....	1
52	07870518	Seal Plug.....	止油塞.....	1
53	07400553	Collar.....	軸環.....	1
54	07400554	Retaining Ring.....	E型扣環.....	1
55	07400555	Thrust Ring.....	墊片.....	1
61	07400561	Needle Bar Lever C.Set.....	針柱槓桿組.....	1
63	07400563	Needle Bar Lever Connecting Rod C.Set.....	針柱槓桿連桿組.....	1
65	07400565	Seal Plug.....	止油塞.....	1
66	07400566	Needle Bar Connecting Link Pin C.Set.....	針柱連桿插銷組.....	2
67	07400567	Main Shaft.....	主軸.....	1
68	07400568	Crankshaft.....	曲軸.....	1
69	07400569	Screw (M6-1X6).....	螺絲.....	1
70	07400570	O-ring.....	O型橡膠環.....	1
71	07870338	Pin.....	插銷.....	1
72	07400572	Retaining Ring.....	扣環.....	2
73	07871249	Seal Plug.....	止油塞.....	1
74	07400574	Collar.....	固定軸環.....	1
75	07400575	Sleeve.....	襯套.....	1
76	07400576	Sleeve.....	襯套.....	2
79	07400579	Ball Bearing.....	滾珠軸承.....	1
80	07400580	O-ring.....	O型橡膠環.....	2

★ 請參照附件1【針距規格表】

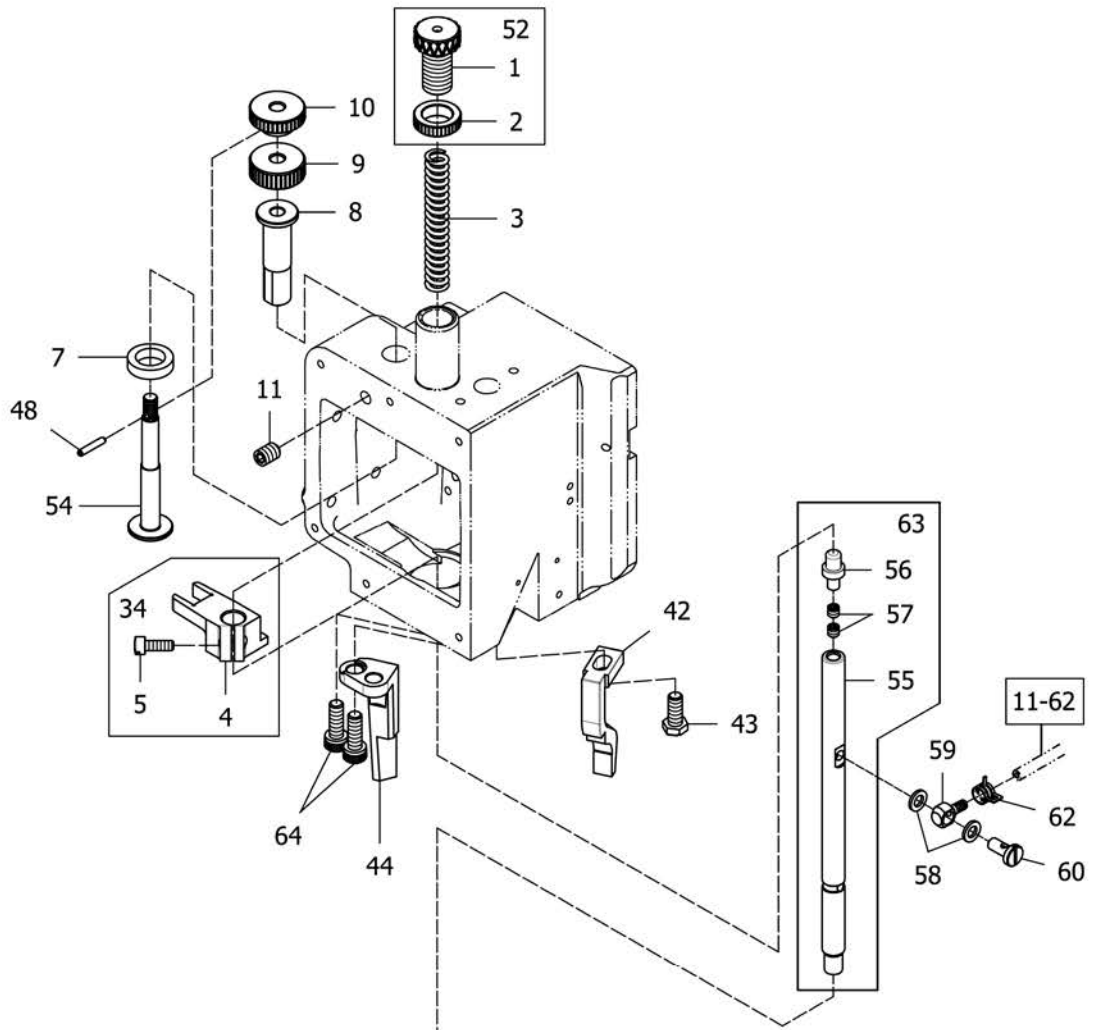

單切刀押腳組

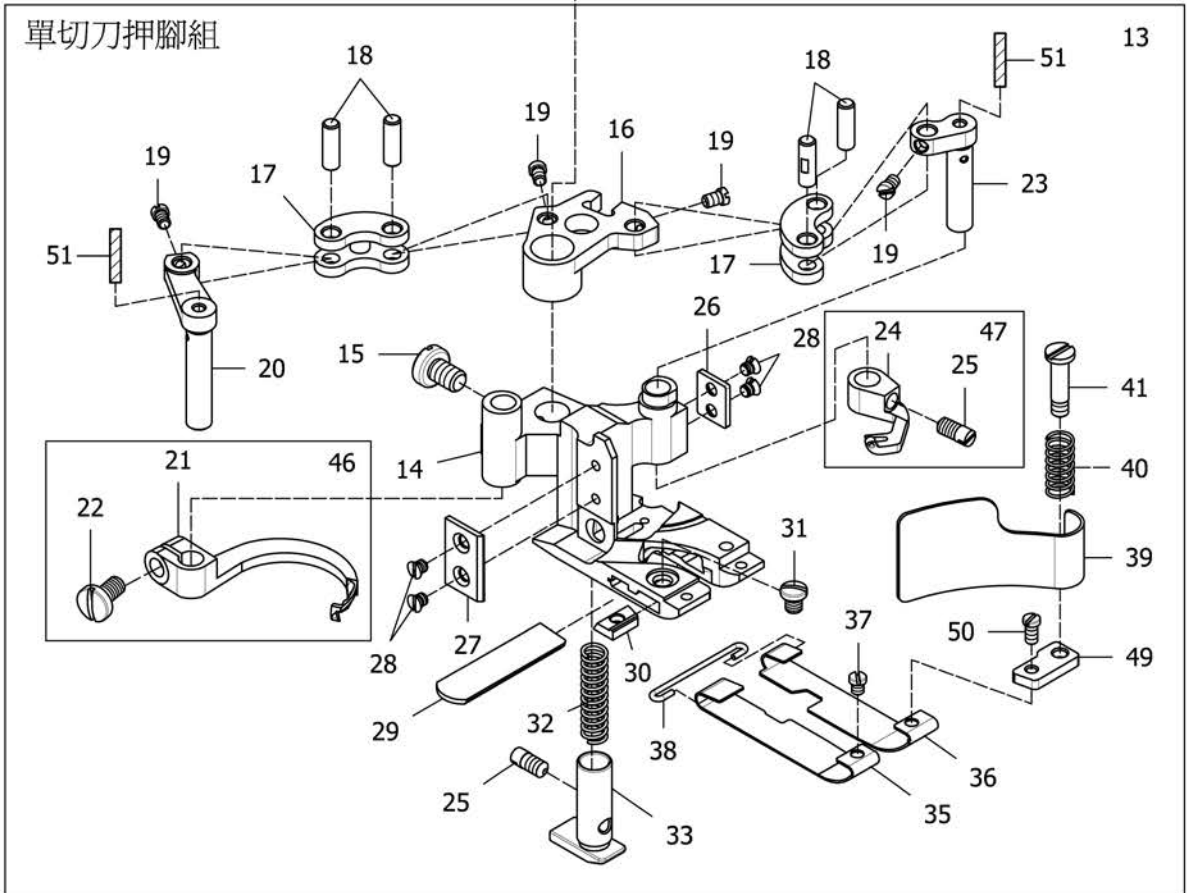

MAIN SHAFT DRIVING MECHANISM**上主軸與針棒機構****6**

Ref.	Parts			Amt.
No.	No.	Description	品名	Req.
1	07400601	Adjusting Screw (M12-1X17).....	調節螺絲.....	1
2	07400602	Lock Nut.....	保險螺帽.....	1
3	07400603	Presser Spring.....	押腳彈簧.....	1
4	07400604	Presser Bar Connecting Bracket.....	押腳推桿連結架.....	1
5	07400605	Screw (1/64-40X10.3).....	螺絲.....	1
7	07400607	Connecting Bracket Cushion.....	連結架襯墊.....	1
8	07400608	Presser Bar Guide.....	押腳導件.....	1
9	07400609	Lock Nut.....	保險螺帽.....	1
10	07400610	Adjusting Nut.....	調節螺帽.....	1
11	07400611	Screw (M6-1X8).....	螺絲.....	1
13	★	One Side Cut Presser Foot C. Set.....	單切押具組.....	1
14	★	One Side Cut Presser Foot.....	單切押腳.....	1
15	07400615	Screw (1/64-40X6.3).....	螺絲.....	1
16	★ 07400616	Carrier/Hook Driving Segment.....	上勾針驅動扇形片.....	1
17	★ 07400617	Carrier/Hook Driving Lever Link.....	上勾針驅動連桿.....	2
18	★ 07400618	Link Pin.....	連桿插銷.....	4
19	07400619	Screw (3/32-56X3.3).....	螺絲.....	4
20	★ 07400620	Thread Hook Driving Lever.....	勾針驅動槓桿.....	1
21	★ 07400621MF	Top Cover Thread Hook.....	上飾線勾針(長).....	1
22	07400622	Screw (9/64-40X6.8).....	螺絲.....	1
23	★ 07400623	Top Cover Thread Carrier Driving Lever.....	上飾線托架驅動槓桿.....	1
24	★ MF	Top Cover Thread Carrier.....	上飾線勾針(短).....	1
25	07400338	Screw (1/8-44X5).....	螺絲.....	2
26	★ 07400626	Presser Foot Attach Piece (Right).....	押腳連接片(右).....	1
27	★ 07400627	Presser Foot Attach Piece (Left).....	押腳連接片(左).....	1
28	07400628	Screw(3/32-56X1.5).....	螺絲.....	4
29	★ 07400629	Lower Knife.....	下切刀片.....	1
30	★ 07400630	Lower Knife Clamp.....	下刀片夾板.....	1
31	07400631	Screw (1/8-44X3.5).....	螺絲.....	1
32	★ 07400632	Yielding Section Spring.....	押腳輔助座彈簧.....	1
33	★ 07400633	Yielding Section.....	押具輔助座.....	1
34	07400634	Presser Bar Connecting Bracket C.Set.....	押腳推桿連結架組.....	1
35	★ 07400635A	Presser Foot Spring Plate (Left).....	押具押板(左).....	1
36	★ 07400636A	Presser Foot Spring Plate (Right).....	押具押板(右).....	1
37	07400637	Screw (3/32-56X2.6).....	螺絲.....	1
38	★ 07400638	Spring Plate Holder.....	彈簧片固定座.....	1
39	★ 07400639	Chip Guard.....	切角防護片.....	1

★ 請參照附件1【針距規格表】

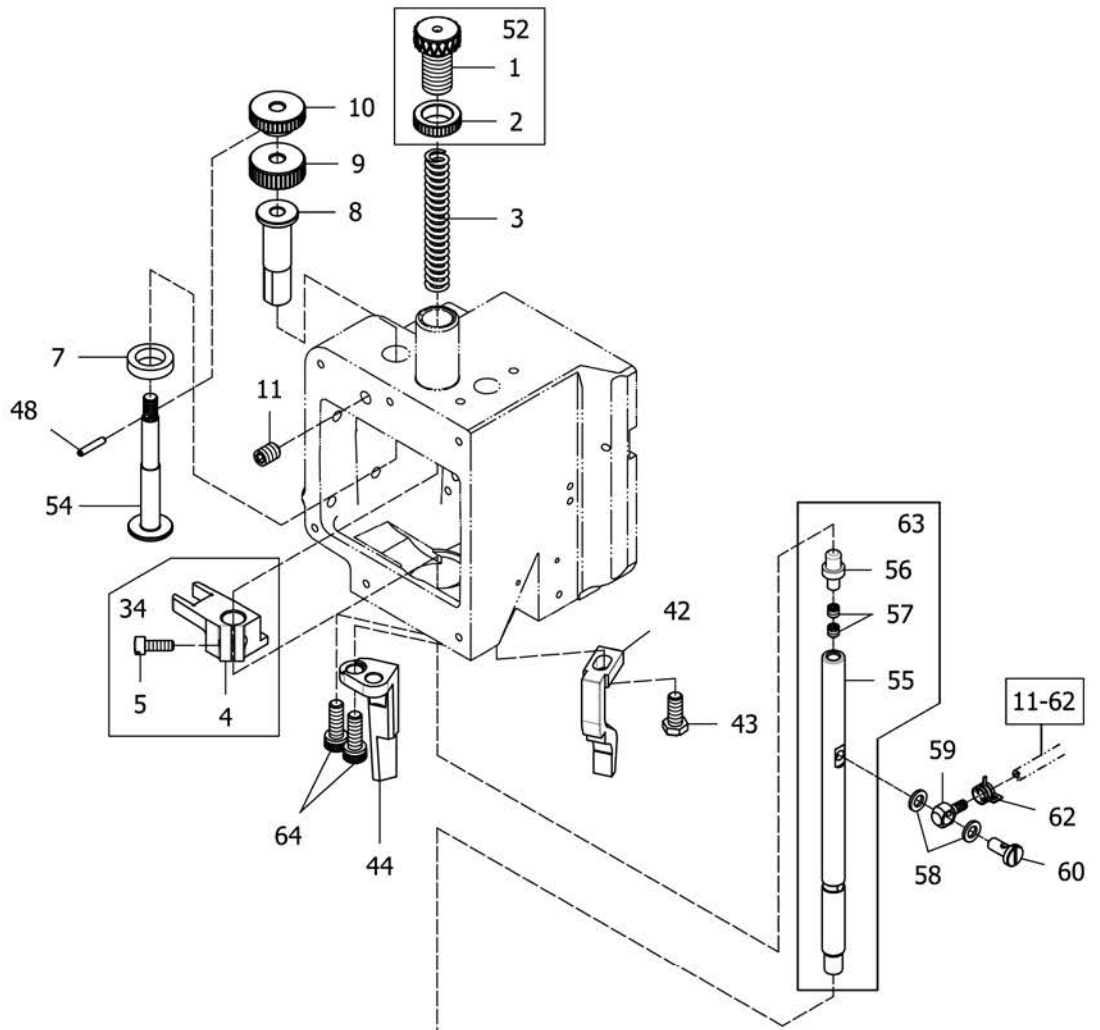

單切刀押腳組

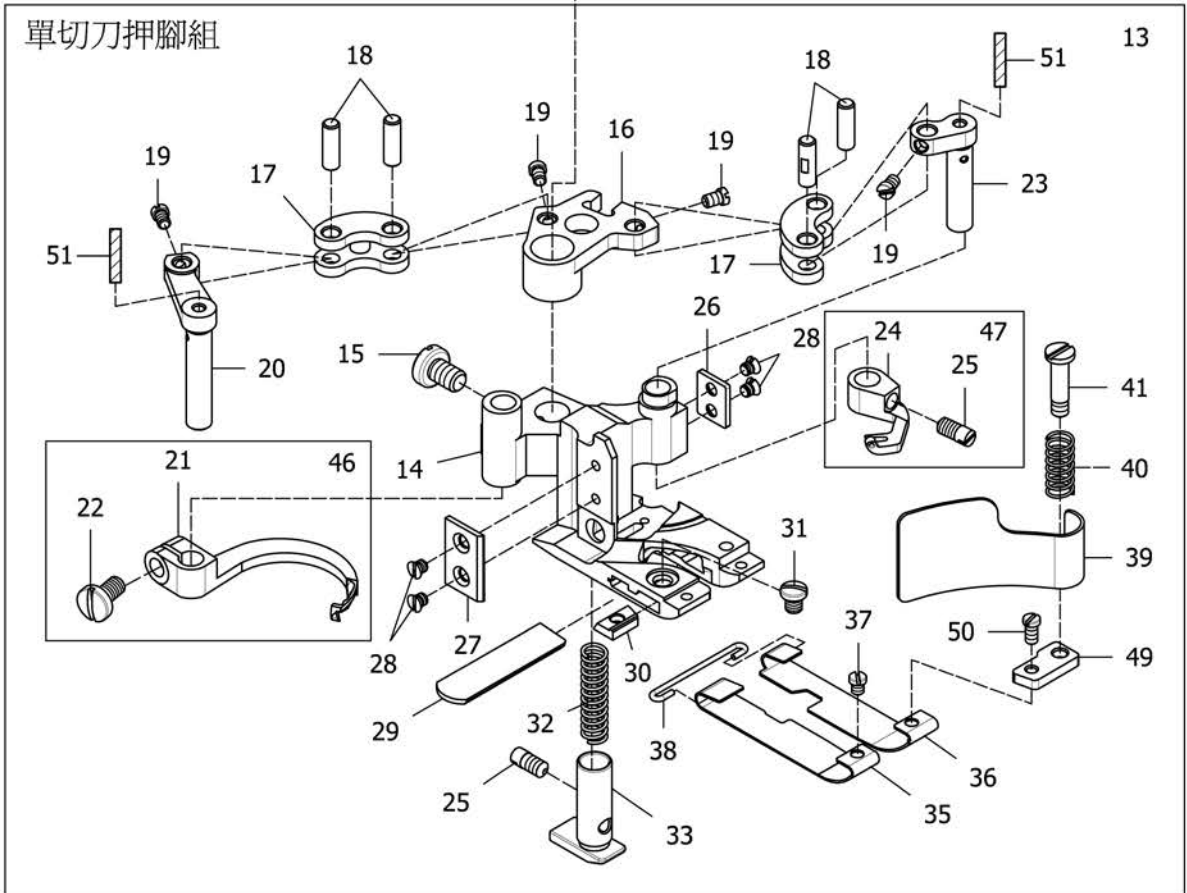

MAIN SHAFT DRIVING MECHANISM**上主軸與針棒機構****6**

Ref.	Parts			Amt.
<u>No.</u>	<u>No.</u>	<u>Description</u>	<u>品 名</u>	<u>Req.</u>
40	★ 07400640	Chip Guard Spring.....	切角防護片彈簧.....	1
41	07400641	Screw (1/8-44X3.4).....	螺絲.....	1
42	07400642	Presser Foot Guide (Right).....	押腳導件(右).....	1
43	07400643	Screw (M5-0.8X12).....	螺絲.....	1
44	07400644	Presser Foot Guide (Left).....	押腳導件(左).....	1
46	07400646MF	Top Cover Thread Hook C.Set.....	上飾線勾針組(長).....	1
47	07400647MF	Top Cover Thread Carrier C.Set.....	上飾線勾針組(短).....	1
48	07400648	Pin.....	插銷.....	1
49	★ 07400649	Spacer.....	墊塊.....	1
50	07400650	Screw (3/32-56X4.8).....	螺絲.....	1
51	★ 07400651	Green Wool.....	綠色毛線.....	2
52	07400652	Adjusting Screw C.Set.....	調節螺絲組.....	1
54	07400654	Presser Foot Adjusting Screw.....	押腳調節彈簧.....	1
55	07400655	Presser Bar.....	押腳推桿.....	1
56	07400656	Plug.....	橡膠塞.....	1
57	07870229	Screw (M4-0.7X4).....	螺絲.....	2
58	07400658	Washer.....	墊片.....	2
59	07400659	Oil Tube Joint.....	油管接頭.....	1
60	07400660	Screw (11/64-40X4).....	螺絲.....	1
62	07400662	Tube Clip.....	油管夾.....	1
63	07400663	Presser Bar C.Set.....	押腳推桿組.....	1
64	07400664	Screw (M5-0.8X12).....	螺絲.....	2

★ 請參照附件1【針距規格表】

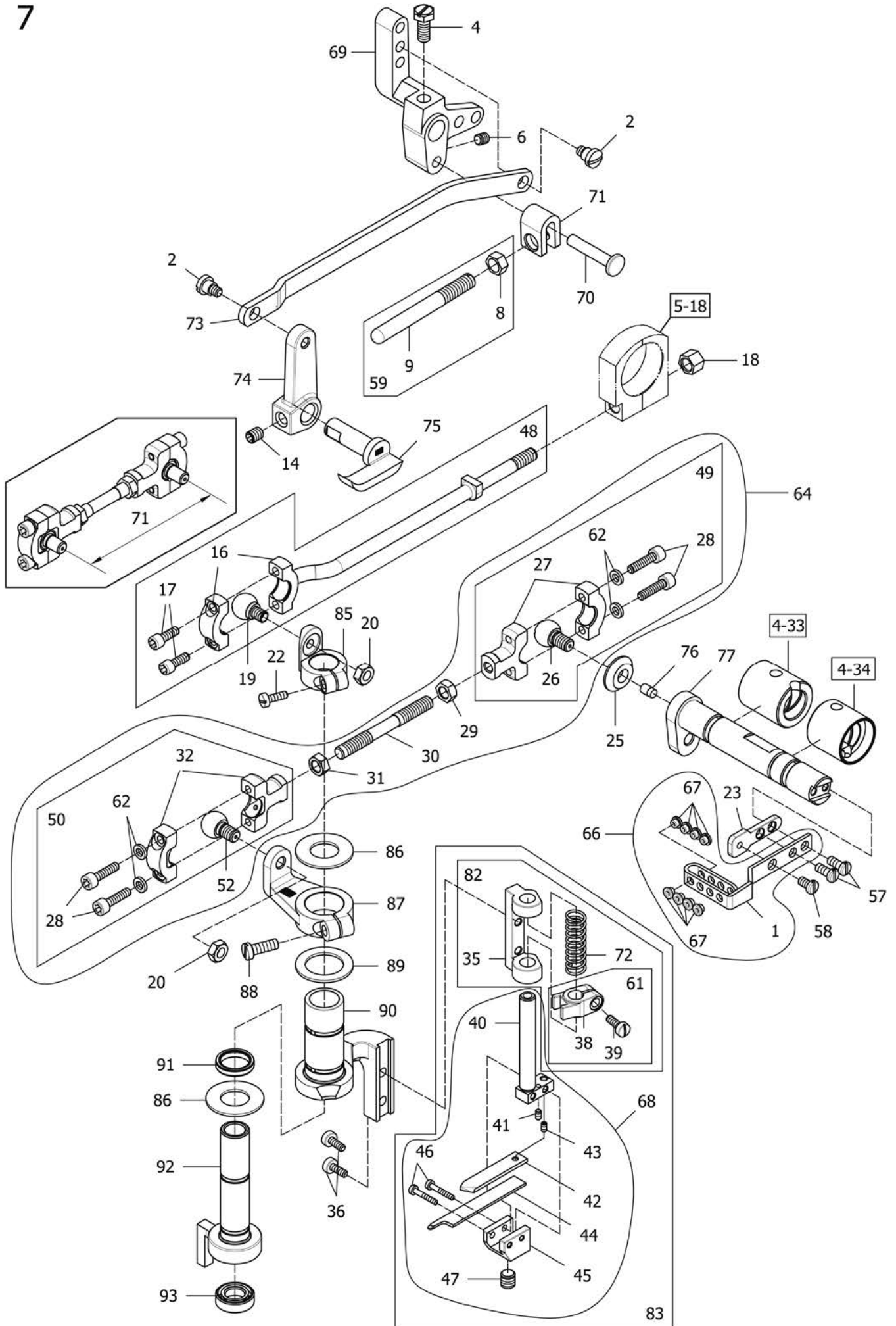

UPPER KNIFE , CARRIER AND HOOK DRIVING MECHANISM 上切刀及上勾針驅動機構 7

Ref.	Parts		Amt.
No.	No.	Description	品 名
			Req.
1	07400701A	Needle Thread Take-up.....	導線架..... 1
2	07400702	Screw (3/16-32X4).....	螺絲..... 2
4	07400704	Screw (7/32-32X12).....	螺絲..... 1
6	07400530	Screw (M5-0.8X5).....	螺絲..... 1
8	07400708	Nut.....	螺帽..... 1
9	07400709	Presser Foot Lifter Stop Plunger.....	擡押腳軸..... 1
14	07400714	Screw (7/32-32X6).....	螺絲..... 1
16	07400716	Carrier Hook Driving Rod (Left).....	上飾線驅動珠殼..... 1
17	07400717	Screw (9/64-40X10).....	螺絲..... 2
18	07400718	Nut.....	螺帽..... 1
19	07400719	Rod Ball (Left).....	上飾線傳動連結球(左)..... 1
20	07400720	Nut.....	螺帽..... 2
22	07400722	Screw(9/64-40X9).....	螺絲..... 1
23	07400723	Bracket.....	托架固定座..... 1
25	07400725	Steady Washer.....	穩定墊圈..... 1
26	07400726	Knife Driving Connection Ball(Right).....	上切刀驅動連結球(右)..... 1
27	07400727	Knife Driving Connection(Right).....	上切刀驅動連結桿(右)..... 1
28	07400728	Screw (M3.5-0.6X14).....	螺絲..... 4
29	07400729	Nut (Left-handed Screw).....	螺帽..... 1
30	07400730	Knife Driving Connecting Rod.....	上切刀驅動連結桿..... 1
31	07400731	Nut.....	螺帽..... 1
32	07400732	Knife Driving Connection (Left).....	上切刀驅動連結桿(左)..... 1
35	07400735	Knife Holder Shank Support.....	上切刀固定座支架..... 1
36	07400736	Screw (9/64-40X8).....	螺絲..... 2
38	07400738	Knife Holder Guide Collar.....	刀台襯套..... 1
39	07400739	Screw (9/64-40X9).....	螺絲..... 1
40	07400740	Knife Holder Shank.....	上切刀固定座柄..... 1
41	07400741	Screw (3/32-56X3.8).....	螺絲..... 1
42	07400742	Knife Support.....	上切刀支架..... 1
43	07400743	Screw (3/32-56X1.2).....	螺絲..... 1
44	★ 07400744	Upper Knife.....	上切刀片..... 1
45	07400745	Knife Holder.....	上刀片固定座..... 1
46	07400746	Screw (3/32-56X7).....	螺絲..... 2
47	07400747	Screw (1/4-40X6).....	螺絲..... 1

★ 請參照附件1【針距規格表】

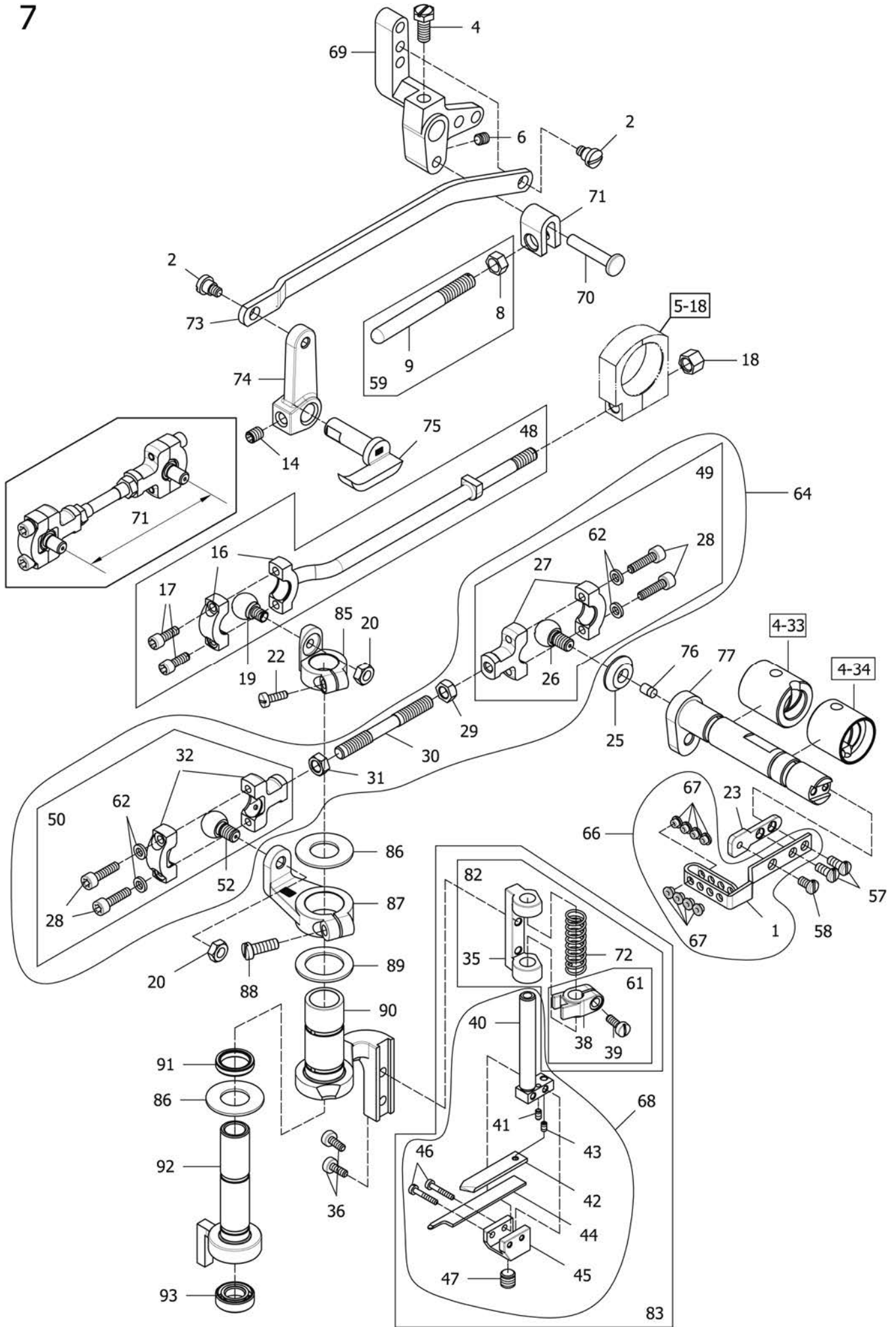

UPPER KNIFE , CARRIER AND HOOK DRIVING MECHANISM 上切刀及上勾針驅動機構 7

Ref.	Parts		Amt.
<u>No.</u>	<u>No.</u>	<u>Description</u>	<u>品 名</u>
			<u>Req.</u>
48	07400748	Carrier/Hook Driving Rod C. Set (Left).....	上飾線驅動珠桿組..... 1
49	07400749	Knife Driving Connection (Right) C. Set.....	上切刀傳動連結桿(右)組.... 1
50	07400750	Knife Driving Connection (Left) C. Set.....	上切刀傳動連結桿(左)組.... 1
52	07400752	Rod Ball (Left).....	上切刀傳動連結球(左)..... 1
57	07400757	Screw (M3.5-0.6X8).....	螺絲(一字頭)..... 2
58	07400758	Screw (M3.5-0.6X6).....	螺絲(一字頭)..... 1
59	07400759	Presser Foot Lifter Stop Plunger C.Set.....	擡押腳軸組..... 1
61	07400761	Knife Holder Guide Collar C.Set.....	刀台襯套組..... 1
62	07400851	Washer.....	墊片..... 4
64	07400764	Knife Driving Connection C.Set.....	上切刀傳動連結桿組..... 1
66	07400766	Needle Thread Take-up C.Set.....	導線架組..... 1
67	07400767	Thread Eyelet.....	過線陶瓷(短.白)..... 8
68	07400768	Knife Holder Shank C.Set.....	上切刀固定座柄組..... 1
69	07400769	Presser Bar Lifter Lever (Large).....	押腳升降槓桿(大)..... 1
70	07400770	Stop Plunger Segment pin.....	擡押腳插銷..... 1
71	07400771	Stop Plunger Segment.....	擡押腳扣..... 1
72	07400772	Knife Holder Spring.....	上切刀固定座彈簧..... 1
73	07400773	Presser Foot Lifter Lever Link.....	押腳升降槓桿連桿..... 1
74	07400774	Presser Bar Lifter Lever (Small).....	押腳升降槓桿(小)..... 1
75	07400775	Presser Bar Lifter Lever.....	押腳拉桿..... 1
76	07871249	Seal Plug.....	止油塞..... 1
77	07400777	Knife Driving Lever.....	上切刀傳動槓桿..... 1
82	07400782	Knife Holder Shank Support C.Set.....	上切刀固定座支架組..... 1
83	07400783	Knife Holder C.Set.....	上刀片固定座組..... 1
85	07400785	Carrier Hook Sleeve Lever.....	勾夾襯套..... 1
86	07400786	Washer.....	墊片..... 2
87	07400787	Carrier Hook Sleeve Lever.....	勾夾襯套..... 1
88	07400788	Screw (11/64-40X12).....	螺絲..... 1
89	07400789	Washer.....	墊片..... 1
90	07400790	Knife Holder Guide Collar.....	刀台座..... 1
91	07400791	Oil Seal.....	油封..... 1
92	07400792	Carrier/Hook Driving Sleeve.....	上飾線驅動襯套..... 1
93	07400793	Oil Seal.....	油封..... 1
95	07400795	Knife Holder Bracket C.Set.....	上刀片固定座托架組..... 1

8

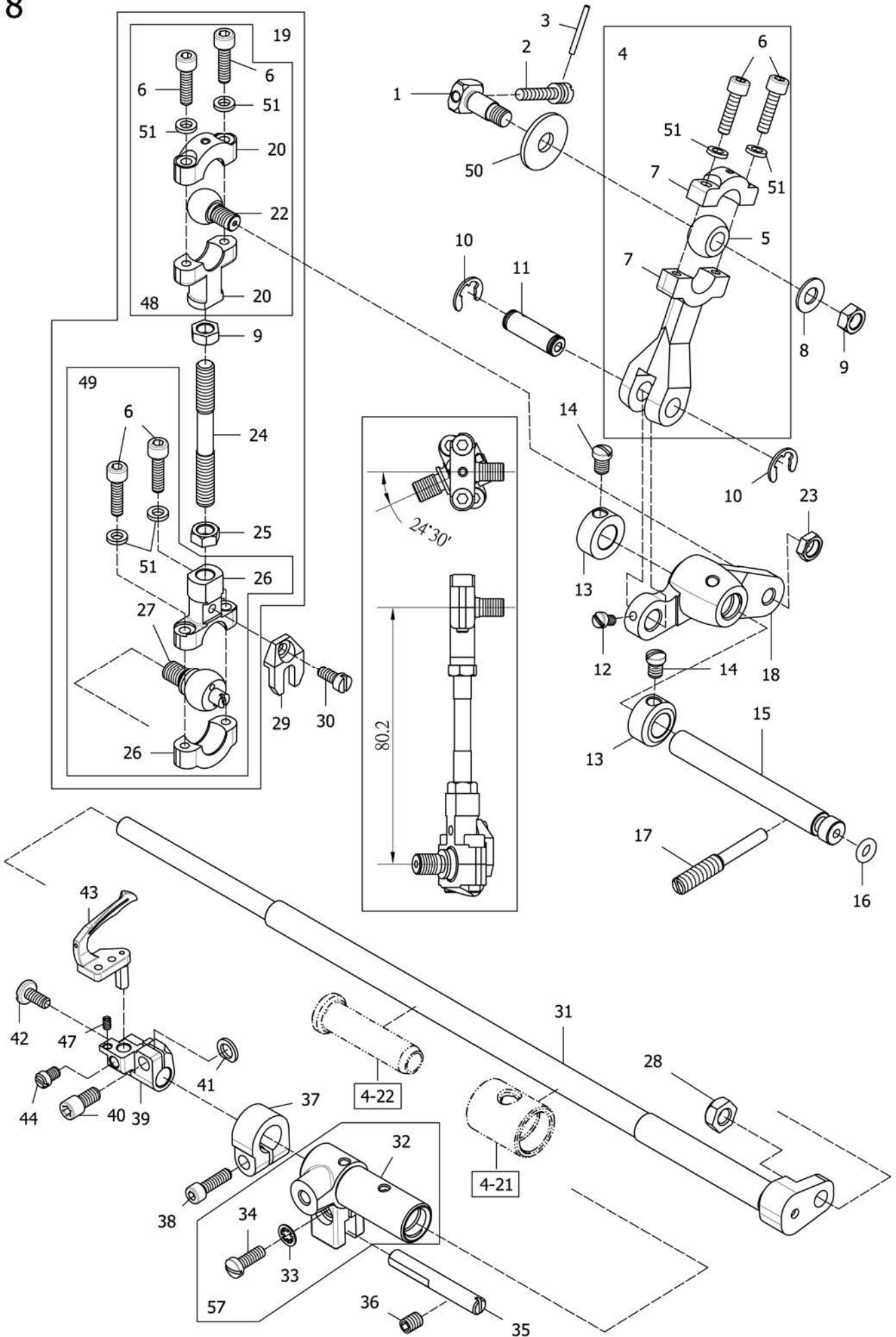

LOOPER DRIVING MECHANISM**下勾針驅動機構****8**

Ref.	Parts			Amt.
<u>No.</u>	<u>No.</u>	<u>Description</u>	<u>品 名</u>	<u>Req.</u>
1	07400801	Looper Driving Crank Pin.....	下勾針驅動曲柄插銷.....	1
2	07400802	Screw (9/64-40X16.3).....	螺絲.....	1
3	07400803	Roll Pin for Main Shaft.....	插銷.....	1
4	07400804	Looper Lever Driving Rod C. Set.....	下勾針驅動桿組.....	1
5	07400805	Looper Lever Driving Rod Ball.....	下勾針驅動桿球.....	1
6	07400728	Screw (M3.5-0.6X14).....	螺絲.....	6
7	07400807	Looper Lever Driving Rod.....	下勾針驅動桿.....	1
8	07400808	Washer.....	墊片.....	1
9	07400729	Nut (Left-handed Screw).....	螺帽.....	2
10	07400810	Retaining Ring.....	扣環.....	2
11	07400811	Looper Lever Driving Rod Pin.....	下勾針驅動桿插銷.....	1
12	07400812	Screw (1/8-44X5).....	螺絲.....	1
13	07400813	Collar.....	軸環.....	2
14	07400814	Screw (11/64-40X5.8).....	螺絲.....	2
15	07400815	Looper Lever Shaft.....	下勾針槓桿軸.....	1
16	07400816	O-ring.....	O型橡膠.....	1
17	07400817	Screw (7/32-32X18).....	螺絲.....	1
18	07400818	Looper Lever.....	下勾針槓桿.....	1
19	07400819	Looper Driving Connection Rod C. Set.....	下勾針驅動連桿組.....	1
20	07400820	Looper Driving Connection(Upper).....	下勾針驅動連桿(上).....	1
22	07400822	Looper Driving Connection Ball(Upper).....	下勾針驅動連桿球(上).....	1
23	07400823	Nut.....	螺帽.....	1
24	07400730	Looper Driving Connecting Rod.....	下勾針驅動連結桿.....	1
25	07400731	Nut.....	螺帽.....	1
26	07400826	Looper Driving Connection(Lower).....	下勾針驅動連桿(下).....	1
27	07400827	Looper Driving Connection Ball(Lower).....	下勾針驅動連桿球(下).....	1
28	07400828	Nut.....	螺帽.....	1
29	07400829	Steady Fork.....	穩定叉.....	1
30	07400830	Screw (M3.5-0.6X8).....	螺絲.....	1
31	07400831	Looper Rocker Shaft.....	下勾針搖桿軸.....	1
32	07400832	Looper Rocker Shaft Sleeve.....	下勾針搖桿軸套筒.....	1
33	07400833	Washer.....	墊片.....	1
34	07400107	Screw (9/64-40X10.8).....	螺絲.....	1
35	07400835	Looper Rocker Shaft Sleeve Guide.....	下勾針搖桿軸套筒導件.....	1
36	07400836	Screw (3/16-32X8).....	螺絲.....	1
37	07400837	Collar.....	下勾針搖桿軸環.....	1
38	07400838	Screw(11/64-40X13).....	螺絲.....	1
39	07400839	Looper Holder.....	下勾針固定座.....	1
40	07400840	Screw (11/64-40X8.3).....	螺絲.....	1

8

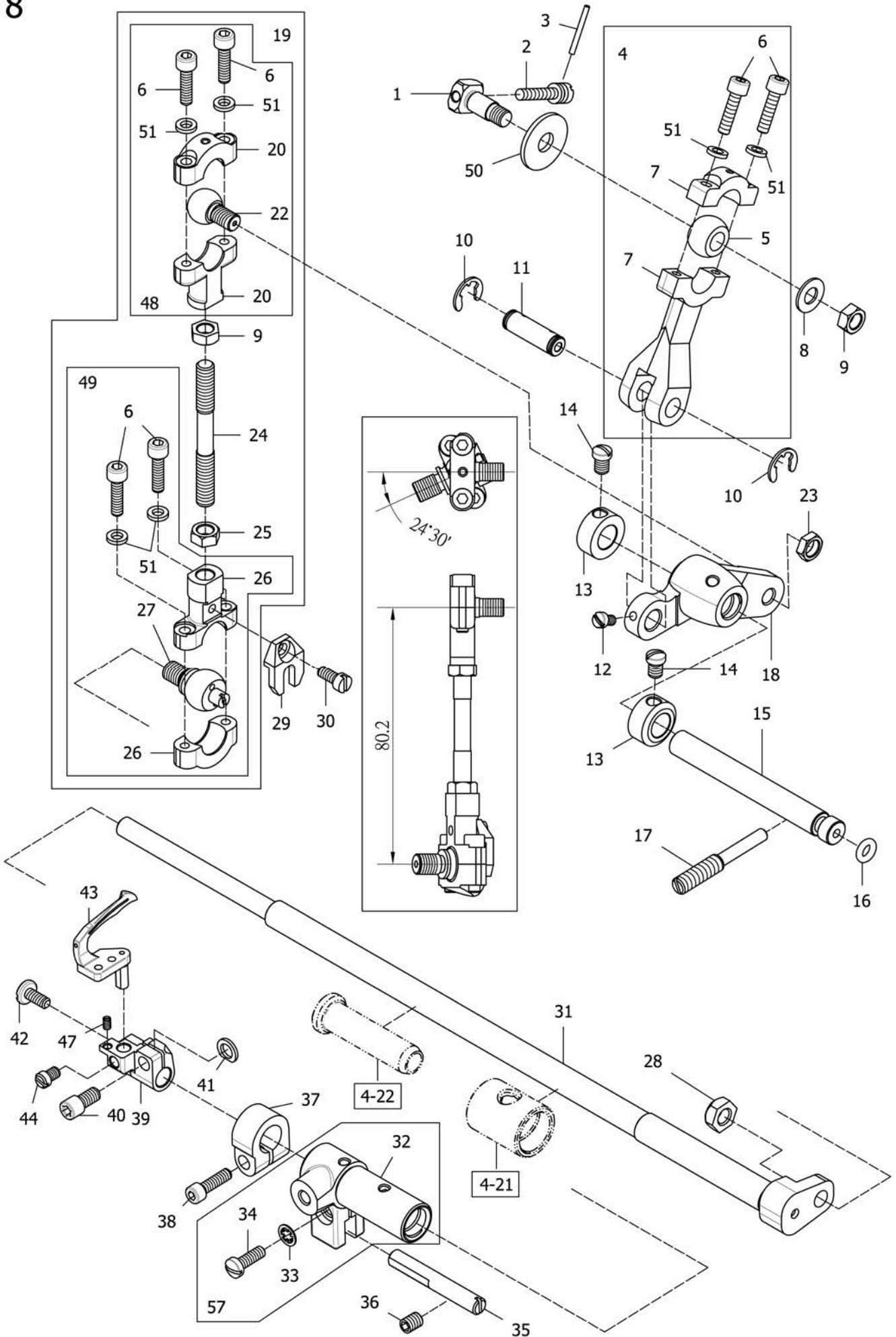

LOOPER DRIVING MECHANISM

下勾針驅動機構

8

Ref.	Parts			Amt.
<u>No.</u>	<u>No.</u>	<u>Description</u>	<u>品 名</u>	<u>Req.</u>
41	07400841	Packing.....	襯墊.....	1
42	07400842	Adjusting Screw(9/64-40X8.2).....	調節螺絲.....	1
43	★ 07400843MF	Looper.....	下飾線勾針.....	1
44	07400844	Screw (9/64-40X4.9).....	螺絲.....	1
47	07400847	Screw (3/32-56X3.6).....	螺絲.....	1
48	07400848	Looper Driving Connection(Upper) C. Set.....	下勾針驅動連結組(上).....	1
49	07400849	Looper Driving Connection(Lower) C. Set.....	下勾針驅動連結組(下).....	1
50	07400850	Spacer.....	墊片.....	1
51	07400851	Washer.....	墊片.....	6
57	07400857	Looper Rocker Shaft Sleeve C.Set.....	下勾針搖桿軸套筒組.....	1

★ 請參照附件1【針距規格表】

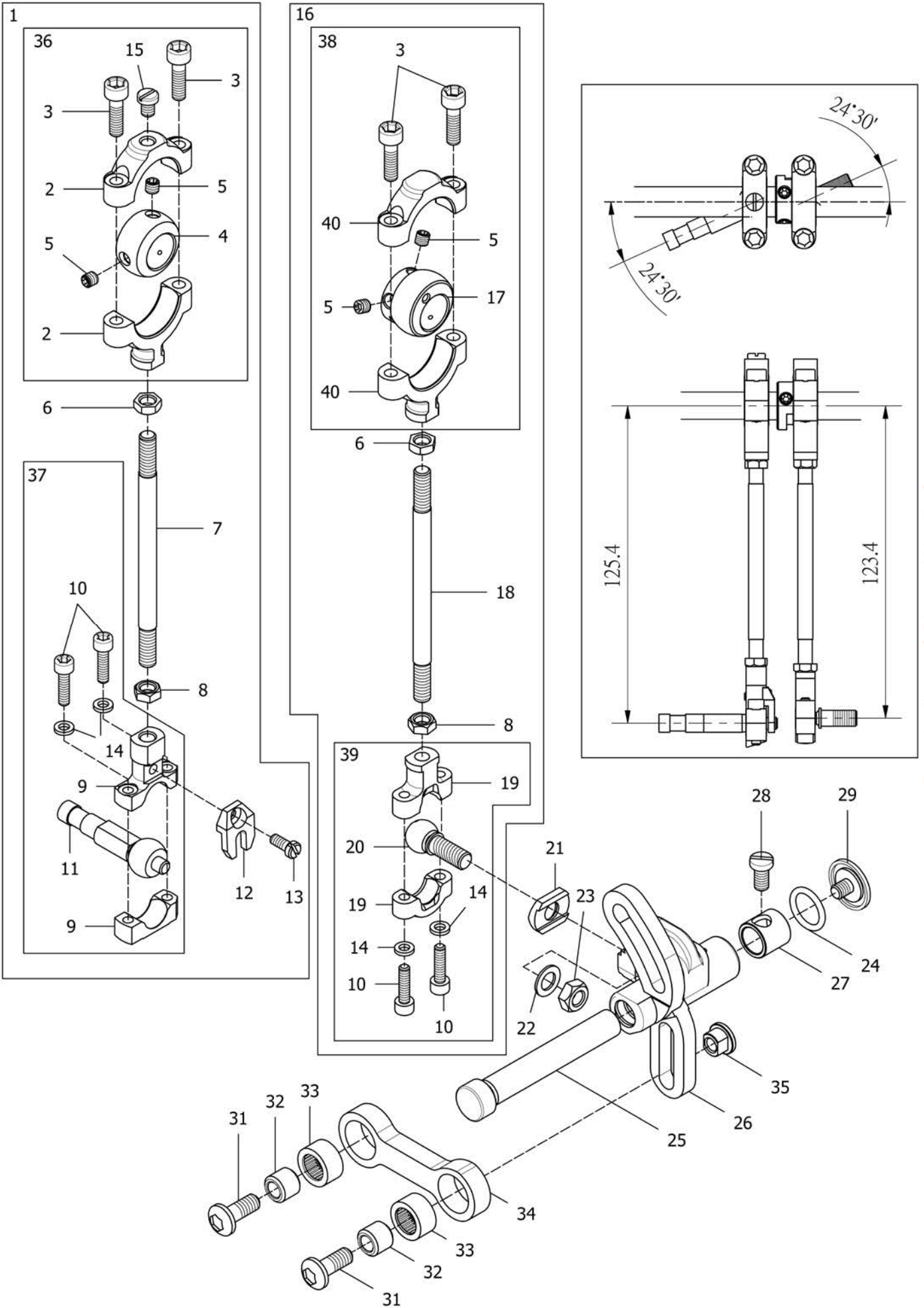

FEED DRIVING CONTROL MECHANISM**送料具驅動機構****9**

Ref.	Parts			Amt.
<u>No.</u>	<u>No.</u>	<u>Description</u>	<u>品 名</u>	<u>Req.</u>
1	07400901	Feed Lift Eccentric C. Set.....	送料具提升偏心輪組.....	1
2	07400902	Feed Lift Connection (Upper).....	送料具提升連桿(上).....	1
3	07400903	Screw (11/64-40X16).....	螺絲.....	4
4	07400904	Feed Lift Eccentric Ball.....	送料具提升偏心輪球.....	1
5	07400225	Screw (11/64-40X4).....	螺絲.....	4
6	07400729	Nut (Left-handed Screw).....	螺帽.....	2
7	07400907	Feed Drive Eccentric Connecting Rod.....	送料具驅動連結桿.....	1
8	07400731	Nut.....	螺帽.....	2
9	07400826	Feed Lift Connection (Lower).....	送料具提升連桿.....	1
10	07400728	Screw (M3.5-0.6X14).....	螺絲.....	4
11	07400911	Feed Lift Connection Ball.....	送料具提升連桿球.....	1
12	07400829	Steady Fork.....	穩定叉.....	1
13	07400830	Screw (M3.5-0.6X8).....	螺絲.....	1
14	07400851	Washer.....	墊片.....	4
15	07400915	Screw (M5-0.8X6).....	螺絲.....	1
16	07400916	Feed Drive Eccentric C. Set.....	送料具驅動偏心輪組.....	1
17	07400917	Feed Drive Eccentric Ball.....	送料具驅動偏心輪球.....	1
18	07400918	Feed Drive Eccentric Connection Rod.....	送料具驅動連結桿.....	1
19	07400732	Feed Drive Connection(Lower).....	送料具驅動連桿(下).....	1
20	07400920	Feed Drive Connection Ball.....	送料具驅動連桿球.....	1
21	07400921	Steady Washer.....	穩定墊片.....	1
22	07400128	Washer.....	墊片.....	1
23	07400828	Nut.....	螺帽.....	1
24	07400924	O-ring.....	O型橡膠環.....	1
25	07400925	Feed Drive Shaft.....	送料具驅動軸.....	1
26	07400926	Feed Drive/Looper Avoid Lever.....	勾齒台座.....	1
27	07400927	Feed Drive Shaft Bushing.....	送料具驅動軸套筒.....	1
28	07400928	Screw (3/16-32X9.1).....	螺絲.....	1
29	07400929	Screw (3/16-32X6).....	螺絲.....	1
31	07400931	Screw (7/32-32X10).....	螺絲.....	2
32	07400932	Looper Avoid Connecting Rod Bushing.....	下勾針連桿襯套.....	2
33	07400933	Needle Bearing.....	軸承.....	2
34	07400934	Looper Avoid Connecting Rod.....	下勾針前後連桿.....	1
35	07400935	Looper Avoid Adjusting Nut.....	調整螺母.....	1
36	07400936	Feed Lift Connection(Upper) C. Set.....	送料具提升連桿(上)組.....	1
37	07400937	Feed Lift Connection(Lower) C. Set.....	送料具提升連桿(下)組.....	1
38	07400938	Feed Drive Eccentric(Upper) C. Set.....	送料具提升偏心輪(上)組.....	1
39	07400939	Feed Drive Eccentric(Lower) C. Set.....	送料具提升偏心輪(下)組.....	1
40	07400940	Feed Drive Eccentric(Upper).....	送料具提升偏心輪(上).....	1

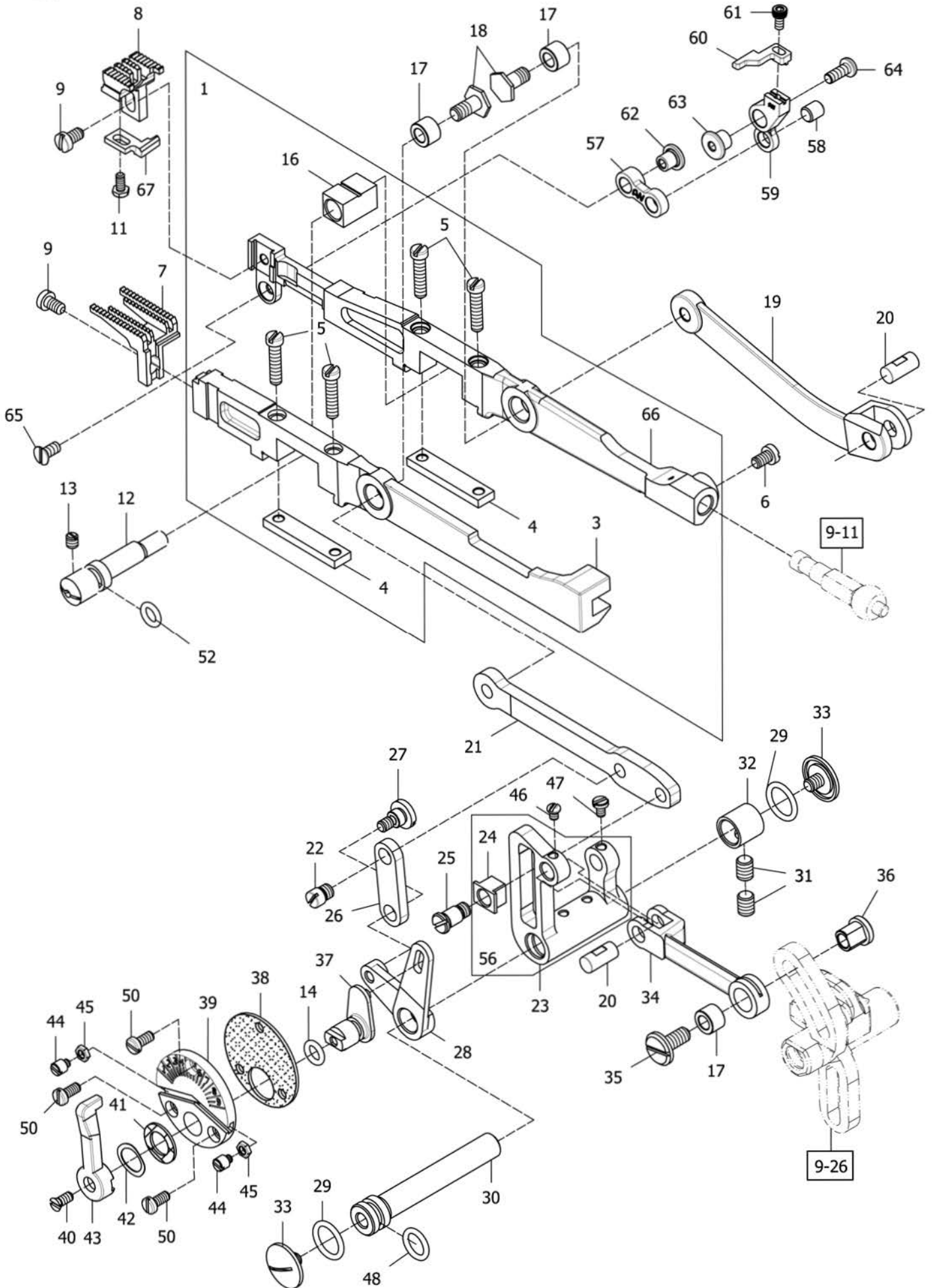

FEED DRIVING MECHANISM**送料具調節機構****10**

Ref.	Parts			Amt.
No.	No.	Description	品名	Req.
1	07401001	Feed Bar C. Set.....	送料具固定座組.....	1
3	07401003	Differential Feed Bar.....	差動送料具固定座.....	1
4	07401004	Feed Bar Plate.....	送料具固定座片.....	2
5	07401005	Screw (11/64-40X18.7).....	螺絲.....	4
6	07401006	Screw (11/64-40X7).....	螺絲.....	1
7	★ 07401007	Differential Feed Dog.....	前送齒.....	1
8	★ 07401008	Main Feed Dog.....	單切後送齒.....	1
9	07400302	Screw (11/64-40X7.8).....	螺絲.....	2
11	07401011	Screw (1/8-44X4.8).....	螺絲.....	1
12	07401012	Feed Bar Eccentric Pin.....	送料具偏心銷.....	1
13	07400508	Screw (11/64-40X6).....	螺絲.....	1
14	07401014	O-ring.....	O型橡膠環.....	1
16	07401016	Feed Bar Slide Block.....	送料具滑塊.....	1
17	07401017	Feed Rocker Link Bushing.....	送料具搖桿套筒.....	3
18	07401018	Screw (7/32-32X6.5).....	螺絲.....	2
19	07401019	Main Feed Bar Driving Link.....	主送料具固定座驅動桿.....	1
20	07401020	Feed Rocker Link Pin.....	送料具搖桿插銷.....	2
21	07401021	Differential Feed Bar Driving Link.....	差動送料具固定座驅動桿.....	1
22	07401022	Screw (7/32-32X5).....	螺絲.....	1
23	07401023	Feed Rocker.....	送料具搖桿.....	1
24	07401024	Differential Feed Bar Driving Link Slider.....	差動送料具固定座驅動桿滑塊.....	1
25	07401025	Screw (7/32-32X4).....	螺絲.....	1
26	07401026	Differential Feed Adjusting Link.....	差動送料具調節桿.....	1
27	07401027	Screw (11/64-40X6.6).....	螺絲.....	1
28	07401028	Differential Feed Adjusting Lever.....	差動送料具調節槓桿.....	1
29	07400924	O-ring.....	O型橡膠環.....	2
30	07401030	Feed Rocker Shaft.....	送料具搖桿軸.....	1
31	07400836	Screw (3/16-32X8).....	螺絲.....	2
32	07400927	Feed Rocker Shaft Bushing.....	送料具搖桿軸套筒.....	1
33	07400929	Screw (3/16-32X6).....	螺絲.....	2
34	07401034	Feed Rocker Link.....	送料具搖桿連桿.....	1
35	07401035	Screw (7/32-32X10.5).....	螺絲.....	1
36	07401036	Feed Adjusting Nut.....	送料具調節螺絲.....	1
37	07401037A	Differential Feed Adjusting Lever (Middle).....	差動送料具調節槓桿(中).....	1
38	07401038	Differential Feed Adjusting Dial Gasket.....	差動送料具調節標度盤墊片.....	1

★ 請參照附件1【針距規格表】

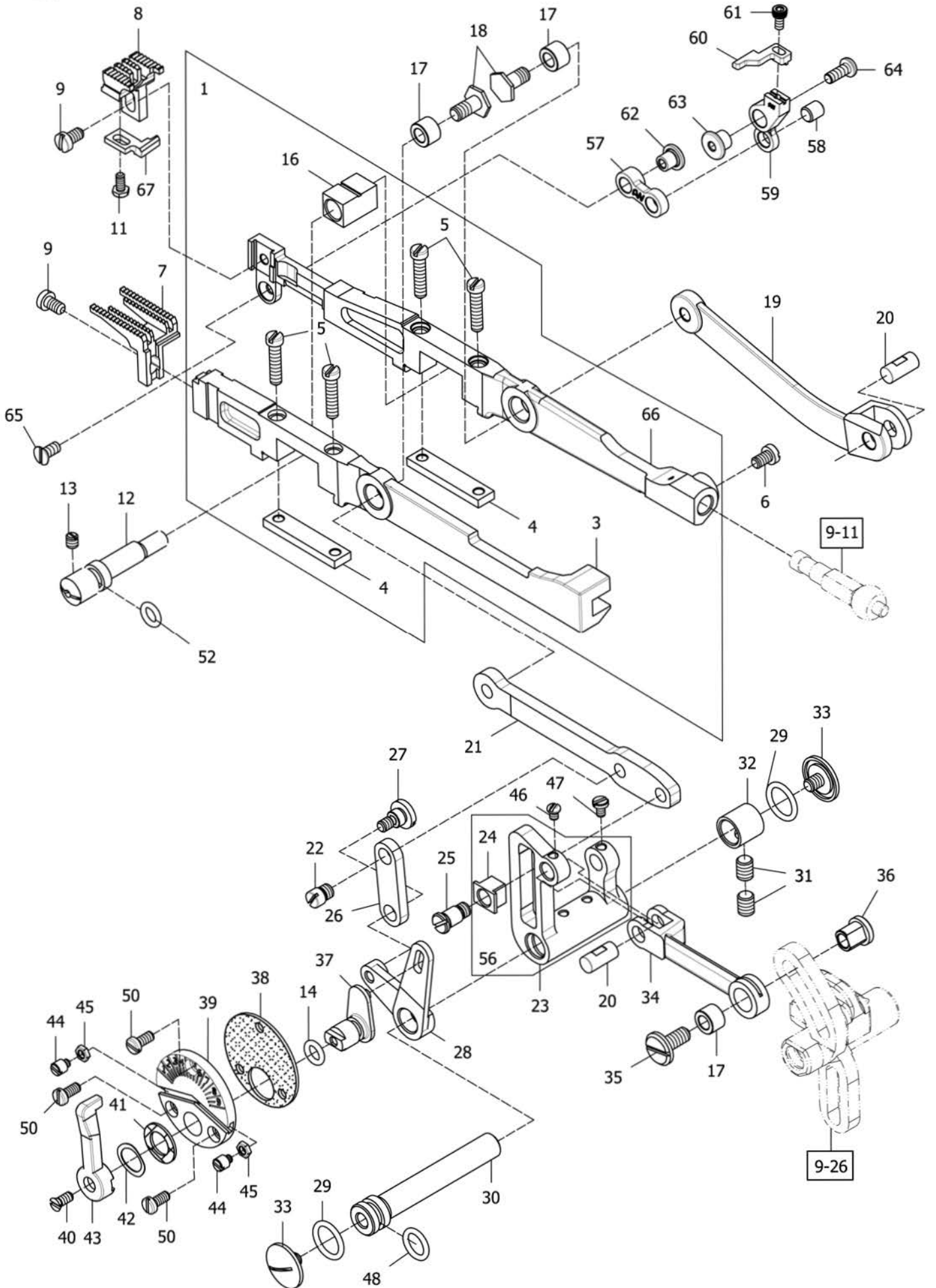

FEED DRIVING MECHANISM

送料具調節機構

10

Ref.	Parts			Amt.
<u>No.</u>	<u>No.</u>	<u>Description</u>	<u>品 名</u>	<u>Req.</u>
39	07401039	Differential Feed Adjusting Dial.....	差動送料具調節標度盤.....	1
40	07400132	Screw (9/64-40X8).....	螺絲.....	1
41	07401041	Spacer (Fiber).....	墊片(纖維).....	1
42	07401042A	Corrugated Washer.....	波狀墊片.....	2
43	07401043	Differential Feed Operating Lever.....	差動送料具操作桿.....	1
44	07401044	Screw (M3-0.5X2.6).....	螺絲.....	2
45	07401045	Nut.....	螺帽.....	2
46	07401046	Screw (1/8-44X5).....	螺絲.....	1
47	07401047	Screw (1/8-44X4.7).....	螺絲.....	1
48	07401048	O-ring.....	O型橡膠環.....	1
50	07400208	Screw (9/64-40X8).....	螺絲.....	3
52	07401052	O-ring.....	O型橡膠環.....	1
56	07401056	Feed Rocker C. Set.....	送料具搖桿組.....	1
57	07401057	Lever Link.....	提環桿.....	1
58	07401058	Connecting Rod Pin.....	連桿插銷.....	1
59	07401059	Needle Guard Holder (Front).....	針擋座(前).....	1
60	07401060	Needle Guard(Front).....	針擋(前).....	1
61	07401061	Screw (M3-0.5X8).....	螺絲.....	1
62	07401062	Connecting Lever Pin.....	連結銷.....	1
63	07401063	Connecting Lever Pin.....	針擋座連結銷.....	1
64	07401064	Screw (M4-0.7X10).....	螺絲.....	1
65	07871602	Screw (M4-0.7X8.5).....	螺絲.....	1
66	07401066	Main Feed Bar.....	主送料具固定座.....	1
67	07401067	Needle Guard(Rear).....	針擋(後).....	1

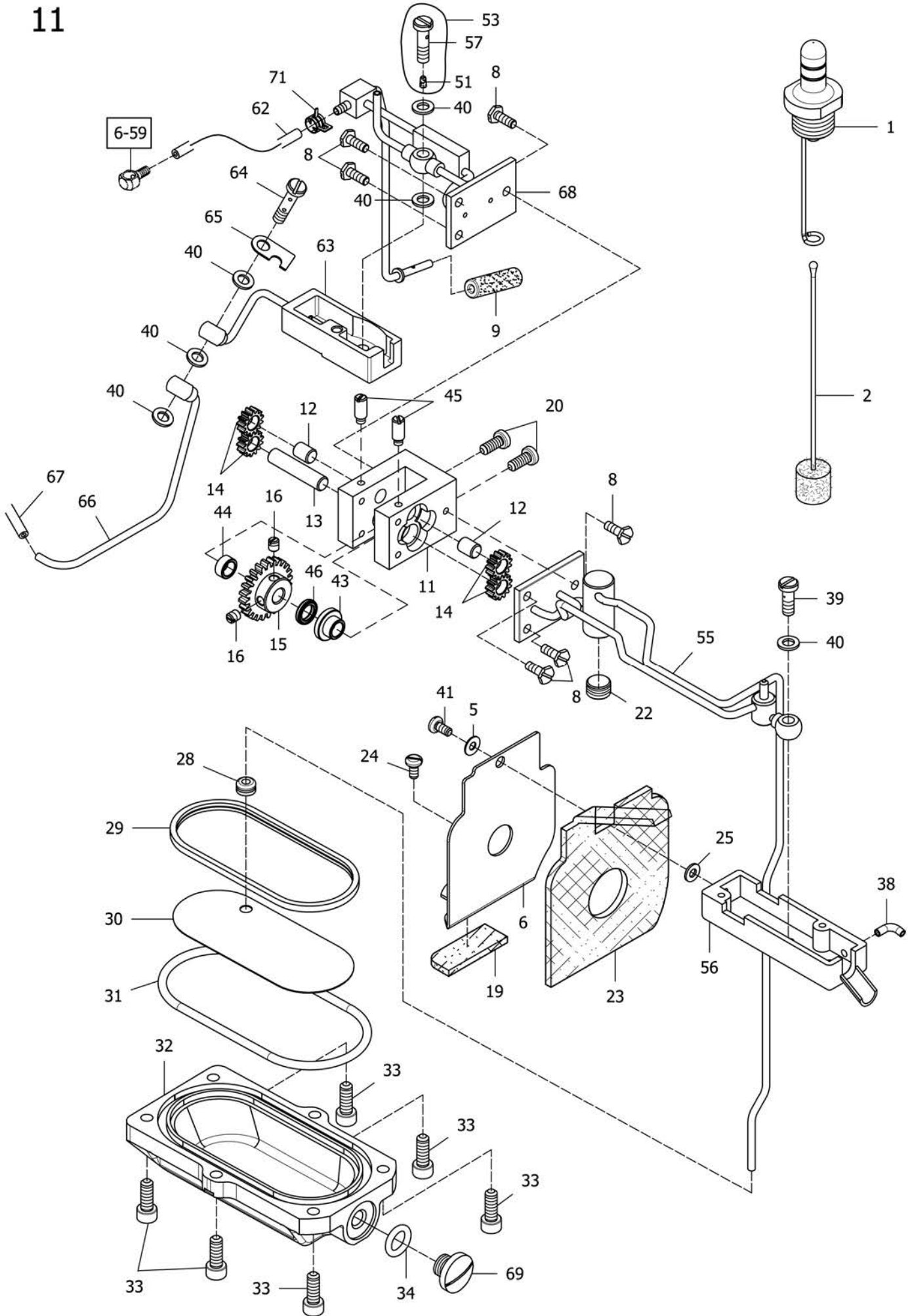

LUBRICATING MECHANISM

給油機構

11

Ref.	Parts			Amt.
<u>No.</u>	<u>No.</u>	<u>Description</u>	<u>品 名</u>	<u>Req.</u>
1	07401101	Crank Chamber Oil Gauge Unit.....	油鏡(後).....	1
2	07401102	Oil Height Indicator.....	油量指示棒.....	1
5	07400139	Washer.....	墊片.....	1
6	07401106	Take-up Oil Defense Plate.....	打線防油板.....	1
8	07401108	Screw (9/64-40X10.3).....	螺絲.....	6
9	07401109	Filter Condenser.....	過濾器.....	1
11	07401111	Pump Housing.....	油泵殼.....	1
12	07401112	Pump Gear Shaft (Short).....	油泵齒輪(短).....	2
13	07401113	Pump Gear Shaft (Long).....	油泵齒輪(長).....	1
14	07401114	Oil Pump Gear.....	油泵齒輪.....	4
15	07401115	Pump Driven Gear.....	油泵從動齒輪.....	1
16	07401116	Screw (11/64-40X5).....	螺絲.....	2
19	07401119	Thread Take-up Oil Defense Unit.....	打線防油墊片(小).....	1
20	07401120	Screw (11/64-40X10.5).....	螺絲.....	2
22	07401122	Screw (M10-1.5X6.1).....	螺絲.....	1
23	07401123	Thread Take-up Oil Defense Unit.....	打線防油墊片(大).....	1
24	07400111	Screw (9/64-40X5.6).....	螺絲.....	1
25	07401125	Washer.....	墊片.....	1
28	07401128	Rubber Bushing.....	橡膠套筒.....	1
29	07401129	Oil Filter Screen Rubber Seal.....	吸油氈篩橡膠油封.....	1
30	07401130	Oil Filter Screen.....	吸油氈篩.....	1
31	07401131	Oil Reservoir Rubber Seal.....	油槽橡膠油封.....	1
32	07401132	Oil Reservoir.....	油槽.....	1
33	07401133	Screw (M5-0.8X14).....	螺絲.....	6
34	07400124	O-ring.....	O型橡膠環.....	1
38	07401138	Oil Tube.....	供油銅管.....	1
39	07401139	Screw (3/16-32X7.5).....	螺絲.....	1
40	07401140	Washer.....	墊片.....	6
41	07400150	Screw (9/64-40X7).....	螺絲.....	1

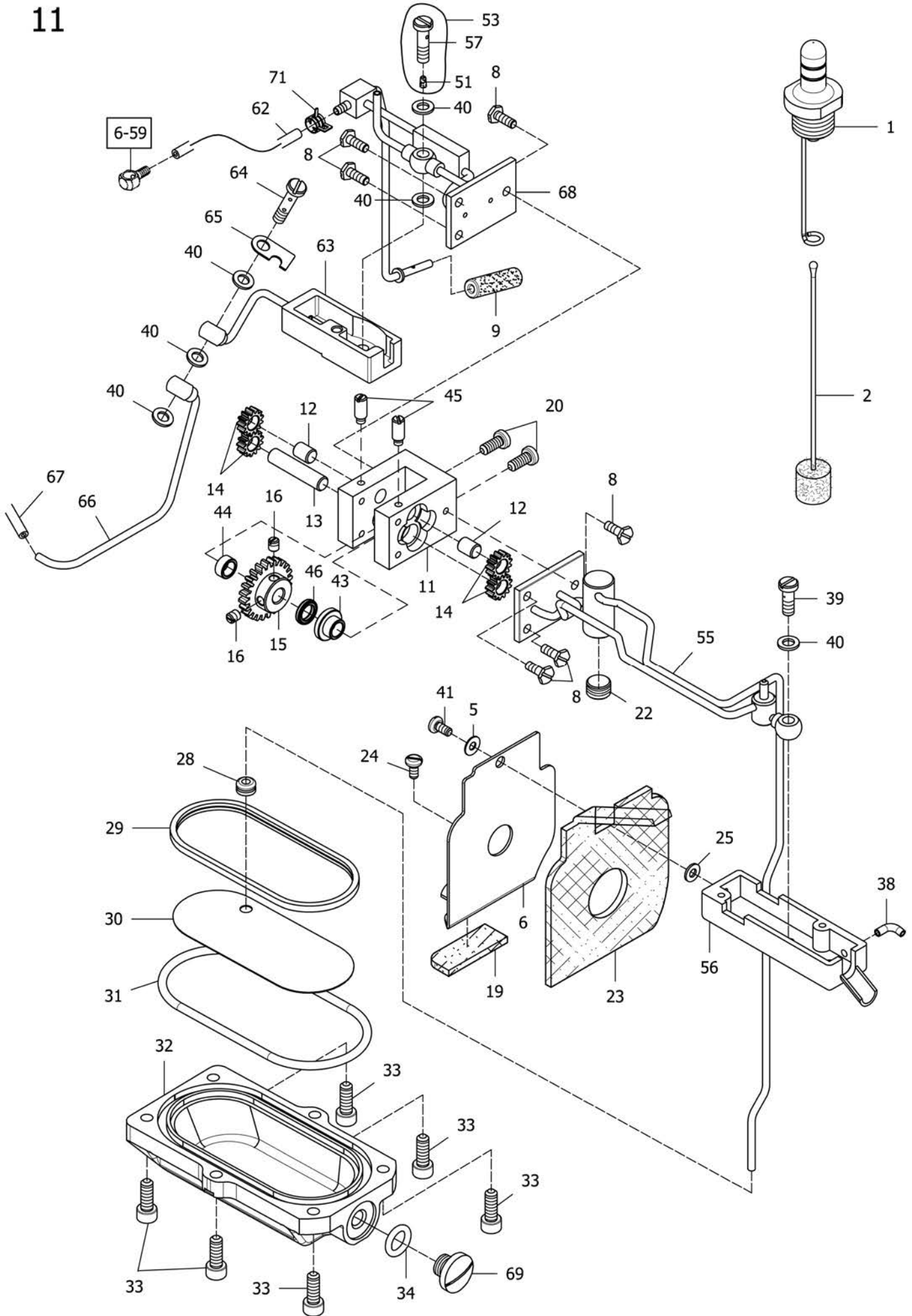

LUBRICATING MECHANISM

給油機構

11

Ref.	Parts			Amt.
<u>No.</u>	<u>No.</u>	<u>Description</u>	<u>品 名</u>	<u>Req.</u>
43	07401143	Bushing(Front).....	套管.....	1
44	07401144	Bushing(Rear).....	套管.....	1
45	07401145	Screw (9/64-40X2).....	螺絲.....	2
46	07400425	Oil Seal.....	油封.....	1
51	07401151	Filter Condenser.....	過濾器.....	1
53	07401153	Filter Condenser C.Set.....	過濾器.....	1
55	07401155	Pump Housing Cover (Front) Unit.....	回油管路(前).....	1
56	07401156	Oil Receiver (Front).....	油量接收器(前).....	1
57	07401157	Fitting Stud Screw (Short) (3/16-32X7.5).....	放油螺絲(短).....	1
62	07401162	Oil Tube (ø3Xø5).....	油管.....	1
63	07401163	Oil Receiver (Rear).....	油量接收器(後).....	1
64	07401164	Fitting Stud Screw (Long) (3/16-32X10.2).....	放油螺絲(長).....	1
65	07401165	Oil Tube Holder.....	油管固定座.....	1
66	07401166	Suction Pipe.....	迴油管.....	1
67	07401167	Oil Tube. (ø2Xø4).....	油管.....	1
68	07401168	Pump Housing Cover (Rear) Unit.....	迴油管路(後).....	1
69	07400180	Screw (3/8-24X8).....	螺絲.....	1
71	07400661	Tube Clip.....	油管夾.....	1

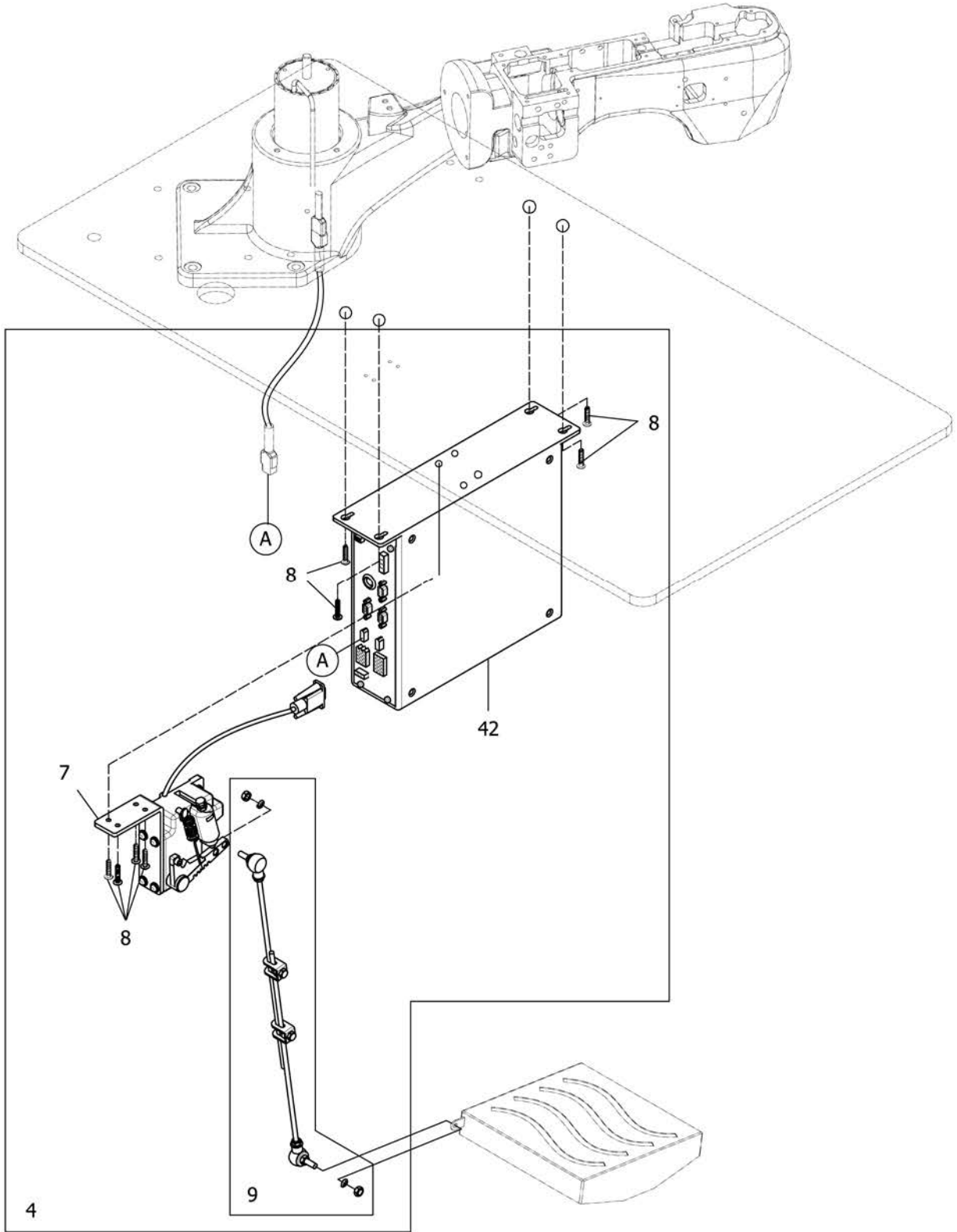

DEIRECTLY DRIVING TYPE MINI-SERVO MOTOR C.SET

伺服馬達機構

12

Ref.	Parts			Amt.
<u>No.</u>	<u>No.</u>	<u>Description</u>	<u>品 名</u>	<u>Req.</u>
2	07401202	Screw (M6-1X20).....	螺絲.....	3
3	07870547	Washer.....	墊片.....	3
4	07401204	Control Box Set.....	控制箱組.....	1
7	07401207	Starter.....	起動器.....	1
8	07401208	Wood Screw.....	木螺絲.....	8
9	07401209	Pitman.....	腳踏板連接桿.....	1
11	07401211	Screw(M5-0.8X6).....	螺絲.....	2
12	07401212	Motor Cover.....	馬達護蓋.....	1
13	07401213	Screw(M4-0.7X4).....	螺絲.....	2
16	07401216	Ball Bearing.....	滾珠軸承.....	1
17	07401217	Bearing Sleeve.....	培林襯套.....	1
18	07870648	Screw(M5-0.8X5).....	螺絲.....	2
19	07401219	Rotor.....	轉子.....	1
20	07401220	Washer.....	墊片.....	1
21	07401221	Nut.....	螺帽.....	2
22	07870583	Directly Driving Type Mini-Servo Motor.....	直驅式微型伺服馬達.....	1
23	07401223	Ball Bearing.....	滾珠軸承.....	1
24	07401224	Motor Cover (Rear).....	馬達後蓋.....	1
25	07401225	Screw(M4-0.7X75).....	螺絲.....	4
26	07401226	Encoder Disc.....	速度檢知板.....	1
27	07401227	Screw(M3-0.5X3).....	螺絲.....	2
28	07401228	Encoder Board.....	相位檢知板.....	1
29	07401229	Screw(M3-0.5X8).....	螺絲.....	3
30	07401230	Cord Holder(Tapping).....	線夾(螺孔).....	1
31	07401231	Cord Holder(Hole).....	線夾(光孔).....	1
32	07401232	Screw(M4-0.7X16).....	螺絲.....	2
34	07401234	Rubber Cushion.....	橡膠墊.....	1
38	07401238	Handwheel.....	手推輪.....	1
39	07401239	Motor Cover (Front).....	馬達前蓋.....	1
41	07401241	Retaining Ring.....	扣環.....	1
42	07401242	Control Box.....	控制箱.....	1

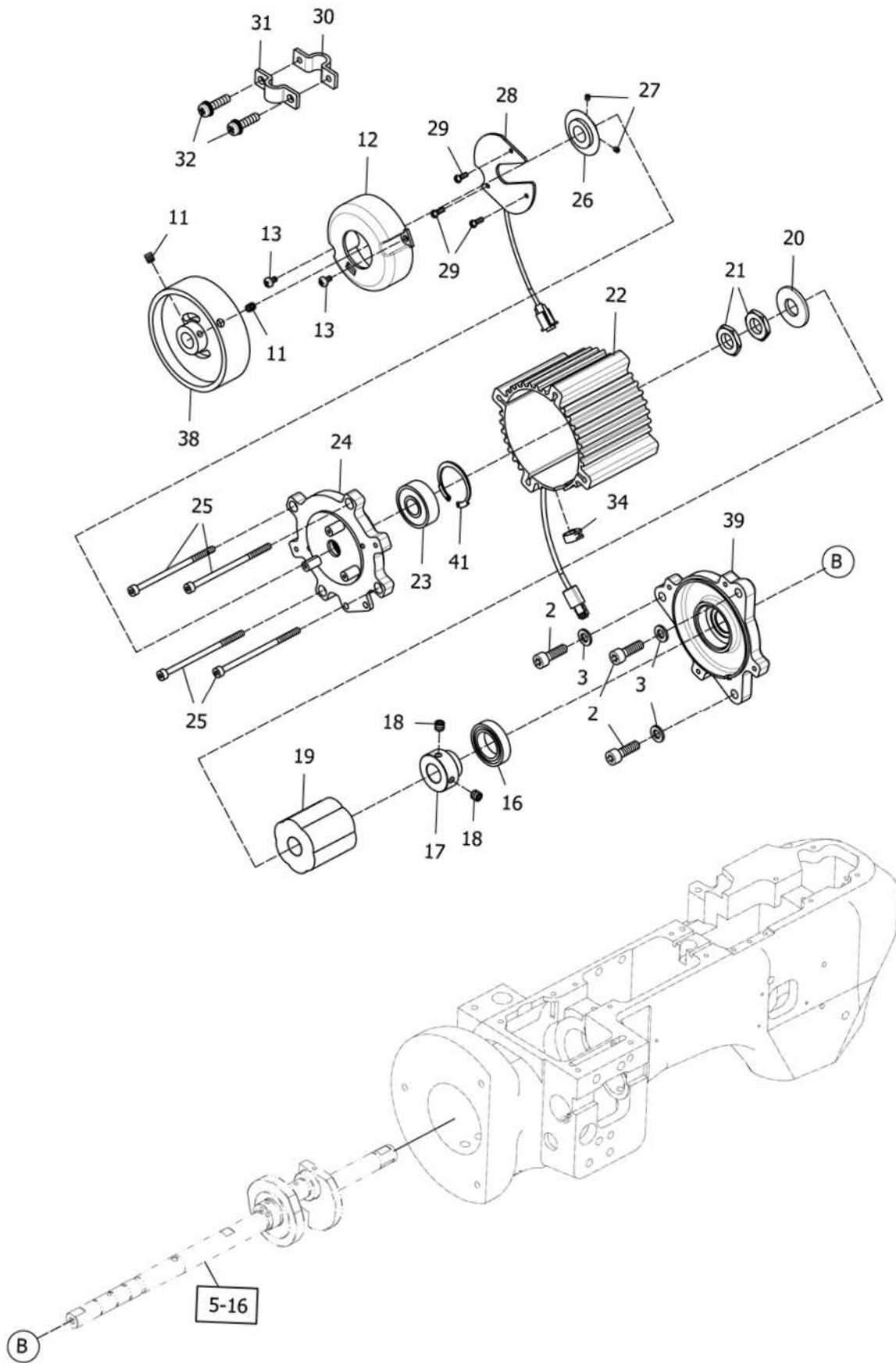

DEIRECTLY DRIVING TYPE MINI-SERVO MOTOR C.SET

伺服馬達機構

12

Ref.	Parts			Amt.
<u>No.</u>	<u>No.</u>	<u>Description</u>	<u>品 名</u>	<u>Req.</u>
2	07401202	Screw (M6-1X20).....	螺絲.....	3
3	07870547	Washer.....	墊片.....	3
4	07401204	Control Box Set.....	控制箱組.....	1
7	07401207	Starter.....	起動器.....	1
8	07401208	Wood Screw.....	木螺絲.....	8
9	07401209	Pitman.....	腳踏板連接桿.....	1
11	07401211	Screw(M5-0.8X6).....	螺絲.....	2
12	07401212	Motor Cover.....	馬達護蓋.....	1
13	07401213	Screw(M4-0.7X4).....	螺絲.....	2
16	07401216	Ball Bearing.....	滾珠軸承.....	1
17	07401217	Bearing Sleeve.....	培林襯套.....	1
18	07870648	Screw(M5-0.8X5).....	螺絲.....	2
19	07401219	Rotor.....	轉子.....	1
20	07401220	Washer.....	墊片.....	1
21	07401221	Nut.....	螺帽.....	2
22	07870583	Directly Driving Type Mini-Servo Motor.....	直驅式微型伺服馬達.....	1
23	07401223	Ball Bearing.....	滾珠軸承.....	1
24	07401224	Motor Cover (Rear).....	馬達後蓋.....	1
25	07401225	Screw(M4-0.7X75).....	螺絲.....	4
26	07401226	Encoder Disc.....	速度檢知板.....	1
27	07401227	Screw(M3-0.5X3).....	螺絲.....	2
28	07401228	Encoder Board.....	相位檢知板.....	1
29	07401229	Screw(M3-0.5X8).....	螺絲.....	3
30	07401230	Cord Holder(Tapping).....	線夾(螺孔).....	1
31	07401231	Cord Holder(Hole).....	線夾(光孔).....	1
32	07401232	Screw(M4-0.7X16).....	螺絲.....	2
34	07401234	Rubber Cushion.....	橡膠墊.....	1
38	07401238	Handwheel.....	手推輪.....	1
39	07401239	Motor Cover (Front).....	馬達前蓋.....	1
41	07401241	Retaining Ring.....	扣環.....	1
42	07401242	Control Box.....	控制箱.....	1

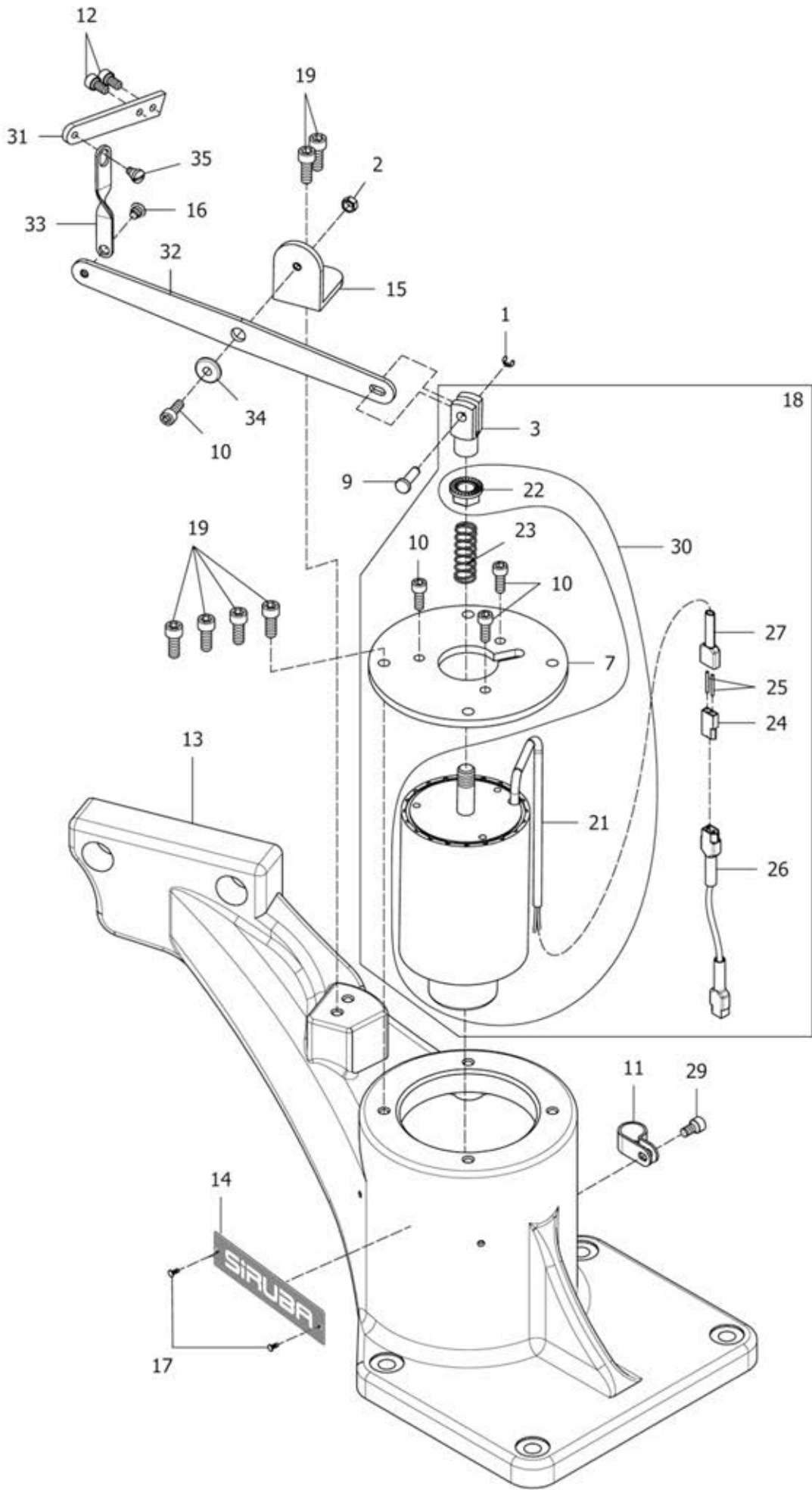

SUPPORTING BLOCK MECHANISM**車台固定座機構****14**

Ref.	Parts			Amt.
<u>No.</u>	<u>No.</u>	<u>Description</u>	<u>品 名</u>	<u>Req.</u>
1	07401401	Retaining Ring.....	扣環.....	1
2	07871028	Nut.....	螺帽.....	1
3	07401403	Presser Foot Lifter Connector.....	擡押腳接頭.....	1
7	07401407	Fix Solenoid Plate.....	電磁鐵固定套.....	1
9	07401409	Fix Pin.....	轉接頭插銷.....	1
10	07804106	Screw(M5-0.8X14).....	螺絲.....	4
11	130101104	Cable Clamp (UC-3).....	配線固定鈕.....	1
12	07870628	Screw(M5-0.8X10).....	螺絲.....	2
13A	07401413A	Supporting Block.....	車台固定座.....	1
14	07400151	Emblem.....	銘牌.....	1
15	07401415	Center Bracket.....	中心座.....	1
16	07401416	Screw(3/16-32X3.5).....	螺絲.....	1
17	07400164	Rivet.....	鉚釘.....	2
18	07401418	Solenoid C.Set.....	電磁鐵組.....	1
19	07401419	Screw(M6-1X16).....	螺絲.....	6
21	07401421	Solenoid.....	電磁鐵.....	1
22	07401422	Nut.....	電磁鐵螺母.....	1
23	07401423	Spring.....	定位緩衝壓簧.....	1
24	07401424	Joint.....	端子座.....	1
25	07401425	Terminal.....	端子.....	1
26	07401426	Relay Line.....	擡押腳中繼線.....	1
27	07401427	Rubber Cover.....	膠套.....	1
29	07401429	Screw(M5-0.8X10).....	螺絲.....	1
30	07401430	Solenoid C.Set.....	電磁鐵組.....	1
31	07401431	Presser Foot Lifter Connecting Lever(S).....	擡押腳連接片(小).....	1
32	07401432	Presser Foot Lifter Connecting Lever(L).....	擡押腳連接片(大).....	1
33	07401433	Presser Foot Lifter Switch Lever.....	擡押腳轉接片.....	1
34	07401434	Center Sleeve.....	中心襯套.....	1
35	07400702	Screw(3/16-32X4).....	螺絲.....	1

1(AW1L厚布料用)

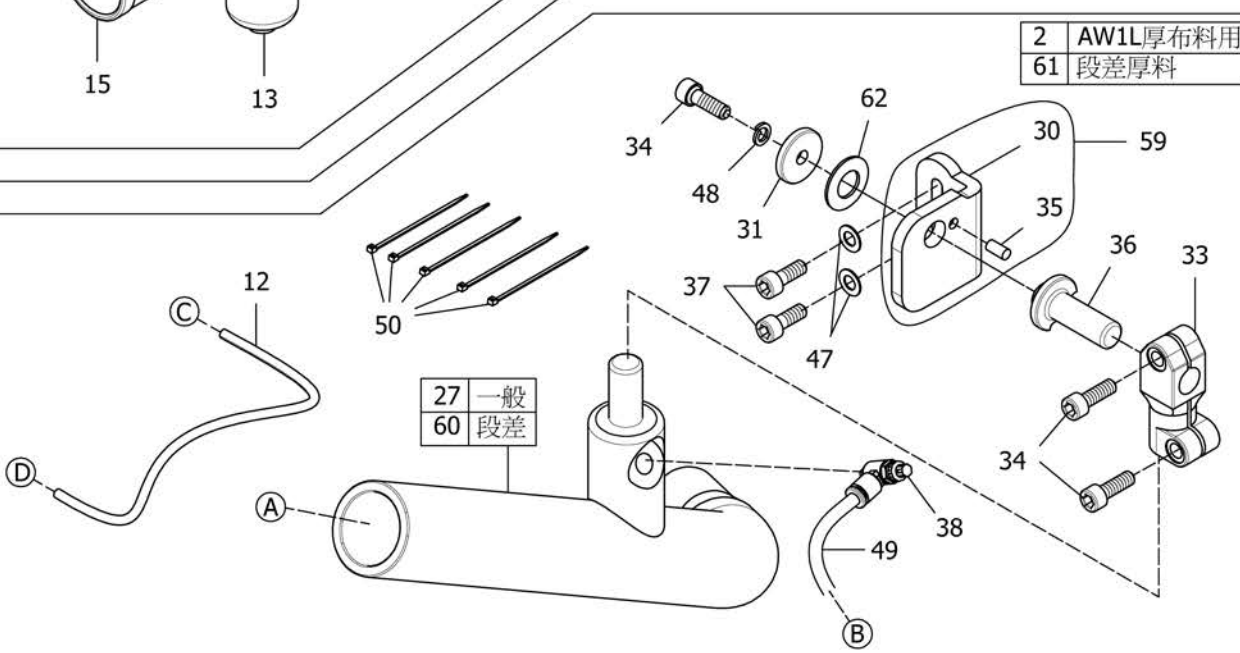
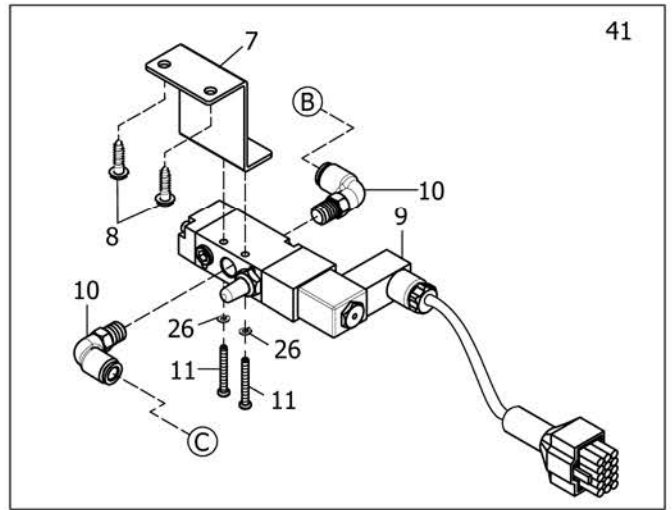
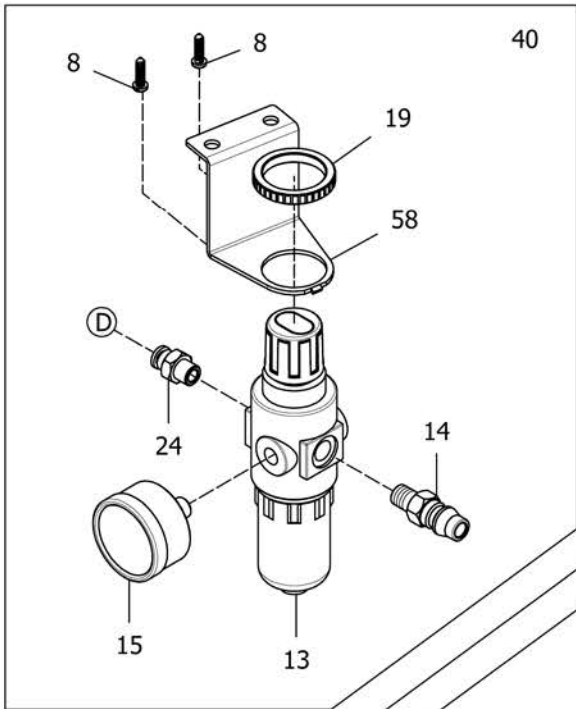
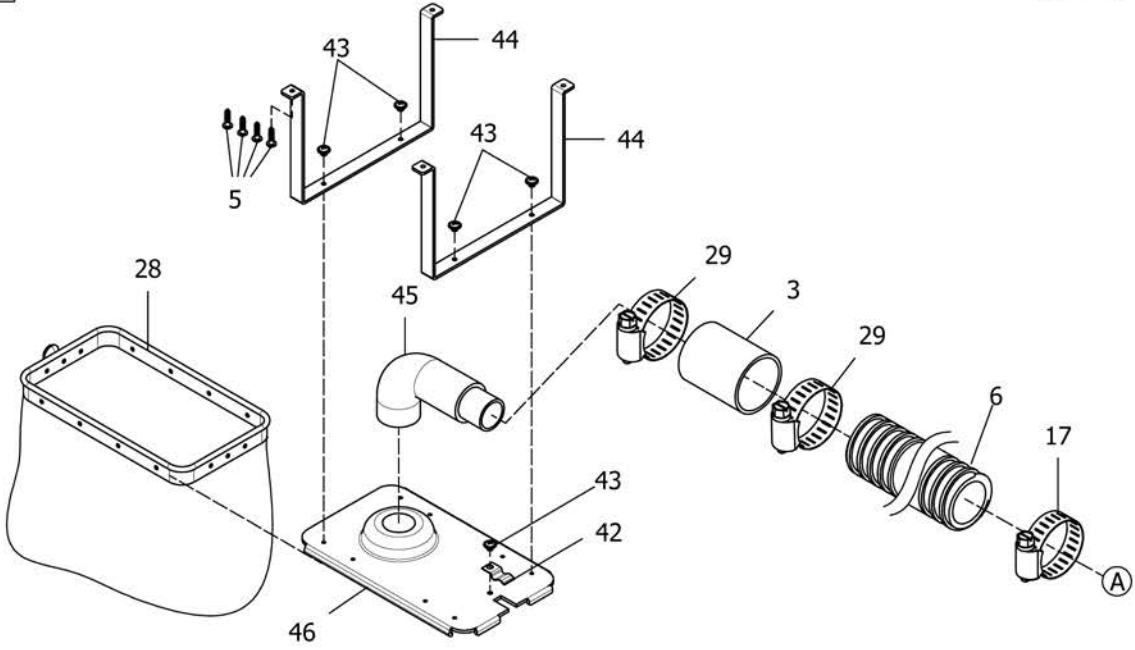

外接式吸布屑組-AW1L、AW1S (選擇配備)

Ref.	Parts			Amt.
No.	No.	Description	品名	Req.
1	07401501A	AW Clear System.....	吸風組(AW1L厚布料用).....	1
2	07401502A	AW Tube System.....	吸風管組(AW1L厚布料用)..	1
3	07401503A	Connect Tube.....	接管.....	1
4	07401504	Fixed Ring.....	套環.....	1
5	07804705	Wood Screw.....	木螺絲.....	4
6	07401506A	Tube.....	風管(大).....	1
7	07804807	Bracket.....	托架.....	1
8	07872402	Wood Screw.....	木螺絲.....	4
9	07804809	Solenoid Valve.....	電磁閥.....	1
10	07804710	Coupler.....	轉接頭.....	2
11	07804811	Screw (M3-0.5X24).....	螺絲.....	2
12	07804712	Tube.....	風管.....	1
13	07872408	Pneumatic Regulator.....	氣壓調節器.....	1
14	07872405	Coupler.....	轉接頭.....	1
15	07872407	Gauge.....	氣磅表.....	1
17	07401517	Fixed Ring.....	套環.....	1
19	07872404	Screw Ring.....	螺環.....	1
24	07872401	Coupler.....	轉接頭.....	1
26	07804826	Spring Washer.....	彈簧墊片.....	2
27	07401527A	Clear Pipe	吸屑管(大)(一般用).....	1
28	07804728	Bag.....	布袋.....	1
29	07401529	Fixed Ring.....	套環.....	2
30	07401530	Bracket.....	托架.....	1
31	07401531	Washer.....	墊片.....	1
33	07401533	Connecting Rod.....	連桿.....	1
34	07401534	Screw (M5-0.8X16).....	螺絲.....	3
35	07401535	Pin.....	插銷.....	1
36	07401536	Connecting Rod Pin.....	連桿插銷.....	1
37	07804106	Screw (M5-0.8X14).....	螺絲.....	2
38	07401538A	Speed Connector.....	調速接頭(B式).....	1
40	07804716	Pneumatic Regulator C.Set.....	氣壓調節器組.....	1
41	07804835	Electromagnetic Valve C.Set.....	氣壓電磁閥組.....	1

1(AW1L厚布料用)

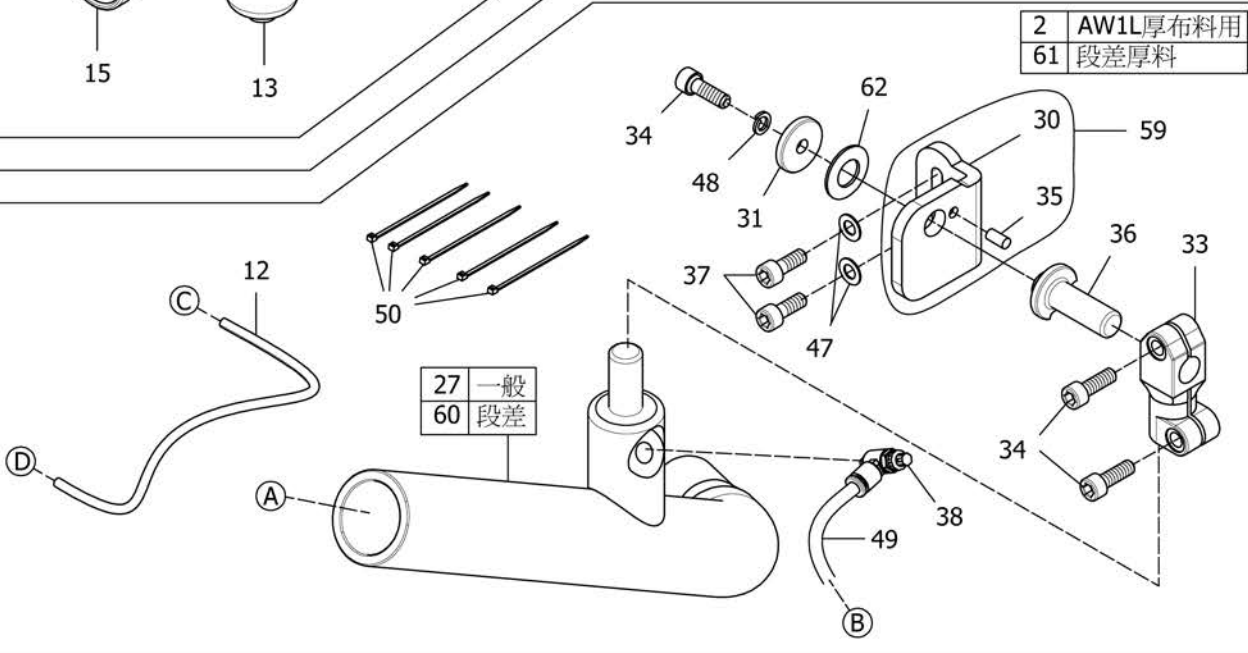
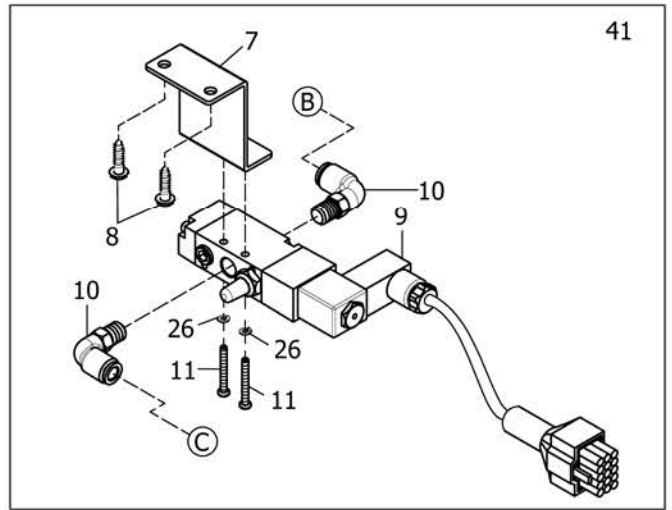
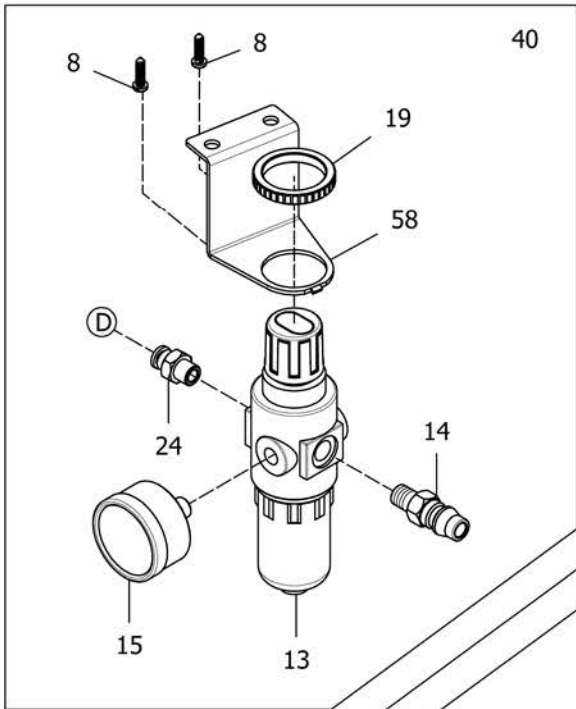
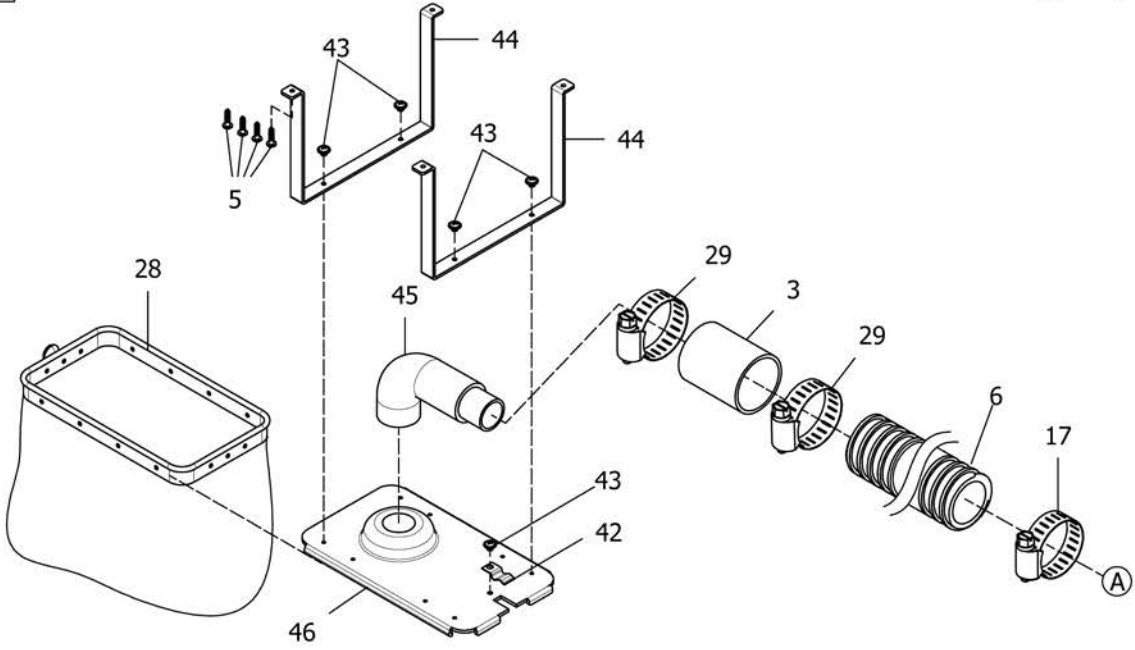

外接式吸布屑組-AW1L、AW1S (選擇配備)

Ref.	Parts			Amt.
<u>No.</u>	<u>No.</u>	<u>Description</u>	<u>品 名</u>	<u>Req.</u>
42	07804734	Spring Washer.....	彈片.....	1
43	07804733	Screw (M4-0 7X3 5).....	螺絲.....	5
44	07804732	Holder.....	固定座.....	2
45	07401545	Clear Pipe.....	吸屑管.....	1
46	07804730	Cover.....	布屑蓋.....	1
47	07401547	Washer.....	墊片(有加強).....	2
48	07401548	Washer.....	彈簧防振墊片.....	1
49	07401549	Tube (Blue).....	氣管(藍)(6mmX60in).....	1
50	130101002	Ties.....	束線帶(CV-250).....	5
51	07401551	Clear Pipe.....	吸屑管(小).....	1
52	07401552	Speed Connector.....	調速接頭(B式).....	1
53	07401553	Connect Tube.....	接管.....	1
54	07401554	Tube.....	風管(小).....	1
55	07401555	AW Tube System.....	吸風管組(AW1S薄布料用)..	1
57	07401557	AW Clear System.....	吸風組(AW1S薄布料用).....	1
58	07872403	Bracket.....	托架.....	1
59	07401559	Bracket C.Set.....	托架組.....	1
60	07401560	Clear Pipe (For 02-4LXX).....	吸屑管(大)(段差用).....	1
61	07401561	AW Tube System (For 02-4LXX).....	吸風管組(AW1L段差用).....	1
62	07401562	Conical Spring Washer.....	錐形彈簧墊圈.....	1

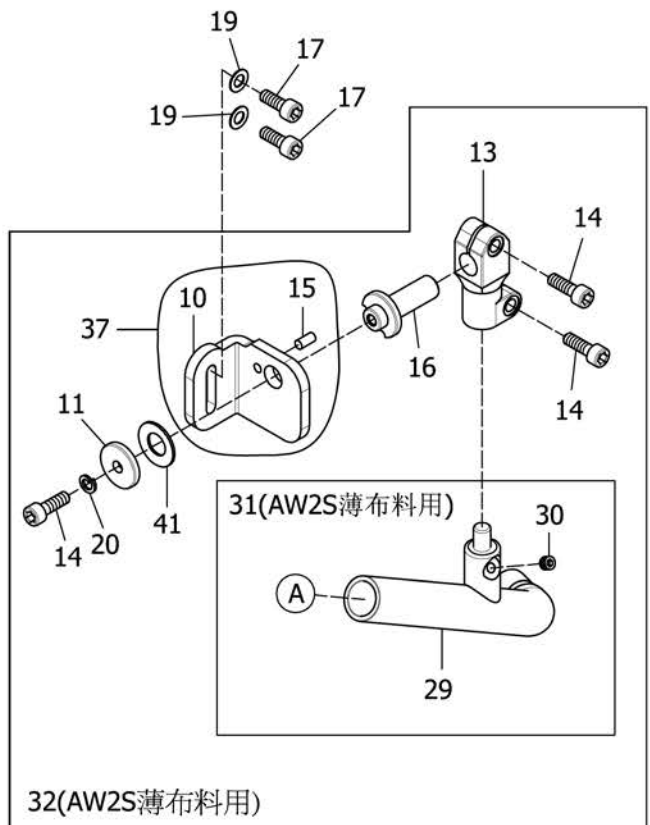
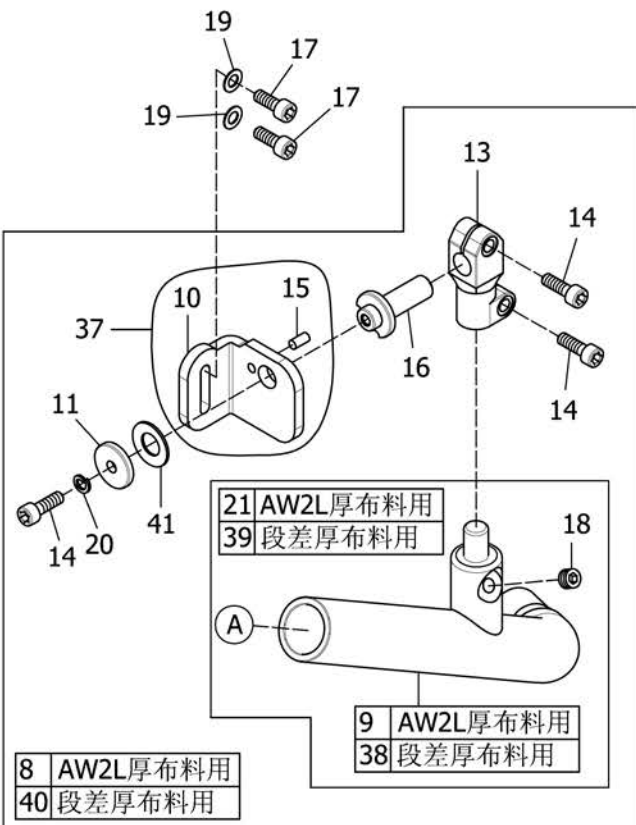
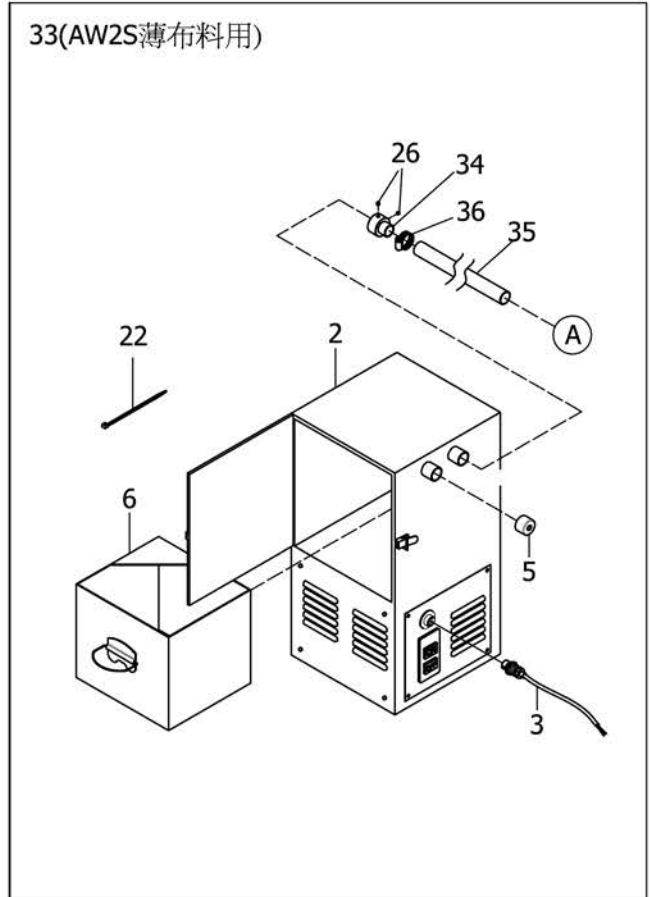
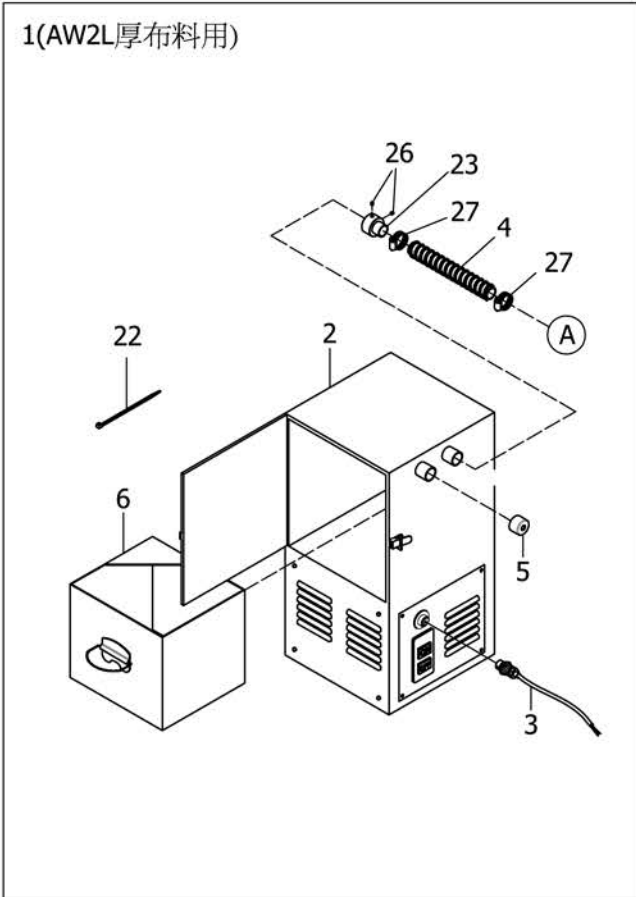

密封式(箱型)吸布屑組-AW2L、AW2S(選擇配備)

Ref.	Parts			Amt.
No.	No.	Description	品 名	Req.
1	07401601	AW Case C.Set.....	吸風箱組(AW2L厚布料用)..	1
2	07804502	Air Case.....	吸風箱.....	1
3	07804503	Electric Wire.....	電源線.....	1
4	07401506A	Tube.....	風管(大).....	1
5	07804505	Plug.....	塞子.....	1
6	07804506	Case.....	布屑集中盒.....	1
8	07401608	AW Tube System.....	吸風管組(AW2L厚布料用)..	1
9	07401527A	Clear Pipe.....	吸屑管(大)(一般用).....	1
10	07401530	Bracket.....	托架.....	1
11	07401531	Washer.....	墊片.....	1
13	07401533	Connecting Rod.....	連桿.....	1
14	07401534	Screw (M5-0.8X16).....	螺絲.....	3
15	07401535	Pin.....	插銷.....	1
16	07401536	Connecting Rod Pin.....	連桿插銷.....	1
17	07804106	Screw (M5-0.8X14).....	螺絲.....	2
18	07401618	Screw (1/8PTX7).....	螺絲.....	1
19	07401547	Washer.....	墊片.....	2
20	07401548	Washer.....	彈簧防振墊片.....	1
21	07401621A	Clear Pipe C.Set.....	吸屑管組(AW2L厚布料用)..	1
22	130101002	Ties.....	束線帶(CV-250).....	5
23	07401623	Connect Tube.....	接管.....	1
26	07401626	Screw (M6-1X5).....	螺絲.....	2
27	07401517	Fixed Ring.....	套環.....	2
29	07401551	Clear Pipe.....	吸屑管(小).....	1
30	07401211	Screw (M5-0.8X6).....	螺絲.....	1
31	07401631	Clear Pipe C.Set.....	吸屑管組(AW2S薄布料用)..	1
32	07401632	AW Tube System.....	吸風管組(AW2S薄布料用)..	1
33	07401633	AW Case C.Set.....	吸風箱組(AW2S薄布料用)..	1
34	07401634	Connect Tube.....	接管.....	1
35	07401554	Tube.....	風管(小).....	1
36	07401504	Fixed Ring.....	套環.....	1
37	07401559	Bracket C.Set.....	托架組.....	1
38	07401560	Clear Pipe (For 02-4LXX).....	吸屑管(大)(段差用).....	1
39	07401639	Clear Pipe C.Set (For 02-4LXX).....	吸屑管組(AW2L段差用).....	1
40	07401640	AW Tube System (For 02-4LXX).....	吸風管組(AW2L段差用).....	1
41	07401562	Conical Spring Washer.....	錐形彈簧墊圈.....	1

THREAD STAND**線架組****17**

Ref.	Parts			Amt.
<u>No.</u>	<u>No.</u>	<u>Description</u>	<u>品 名</u>	<u>Req.</u>
1	07401701	Column Pipe (Lower).....	下線柱.....	1
2	07401702	Column Pipe Connector.....	線柱接頭.....	1
3	07401703	Column Pipe(Upper).....	上線柱.....	1
4	07401704	Thread Guide Holder (Large).....	大過線桿固定座.....	1
5	07401705	Thread Guide Holder (Small).....	小過線桿固定座.....	1
6	07401706	Screw (M4-0.7X11.9).....	螺絲.....	3
7	07401707	Nut.....	螺帽.....	4
8	07401708	Screw (M4-0.7X24.6).....	螺絲.....	1
9	07401709	Thread Guide Arm.....	過線桿連接臂.....	1
10	07401710	Spool Stand (3 Spool Type).....	3孔線軸架.....	2
11	07401711	Thread Hanger (3 Spools Type).....	3孔過線吊臂.....	2
12	07401712	Column Pipe Connector.....	線柱接頭4.....	4
13	07401713	Screw (M6-1X16.8).....	螺絲.....	4
14	07401714	Nut.....	螺帽.....	1
15	07401715	Screw (M5-0.8X16.8).....	螺絲.....	2
16	07401716	Nut.....	螺帽.....	8
17	07401717	Spring Washer.....	彈簧墊片.....	4
18	07401718	Column Cap.....	柱頭蓋.....	1
19	07401719	Washer.....	墊片.....	2
20	07401720	Spring Washer.....	彈簧墊片.....	6
21	07401721	Spool Pin.....	線軸柱.....	6
22	07401722	Thread Guide (6 Spool Type).....	6孔過線桿.....	1
23	07401723	Spool Mat.....	線軸墊.....	6
24	07401724	Spool Seat Disc.....	線軸底盤.....	6
25	07401725	Spool Cushion.....	線軸避震座.....	6
26	07401726	Rubber Spool Cushion.....	橡膠線軸避震座.....	6
28	07401728	Thread Stand.....	線架(四針六線).....	1
29	07401729	Thread Stand.....	線架(五針七線).....	1

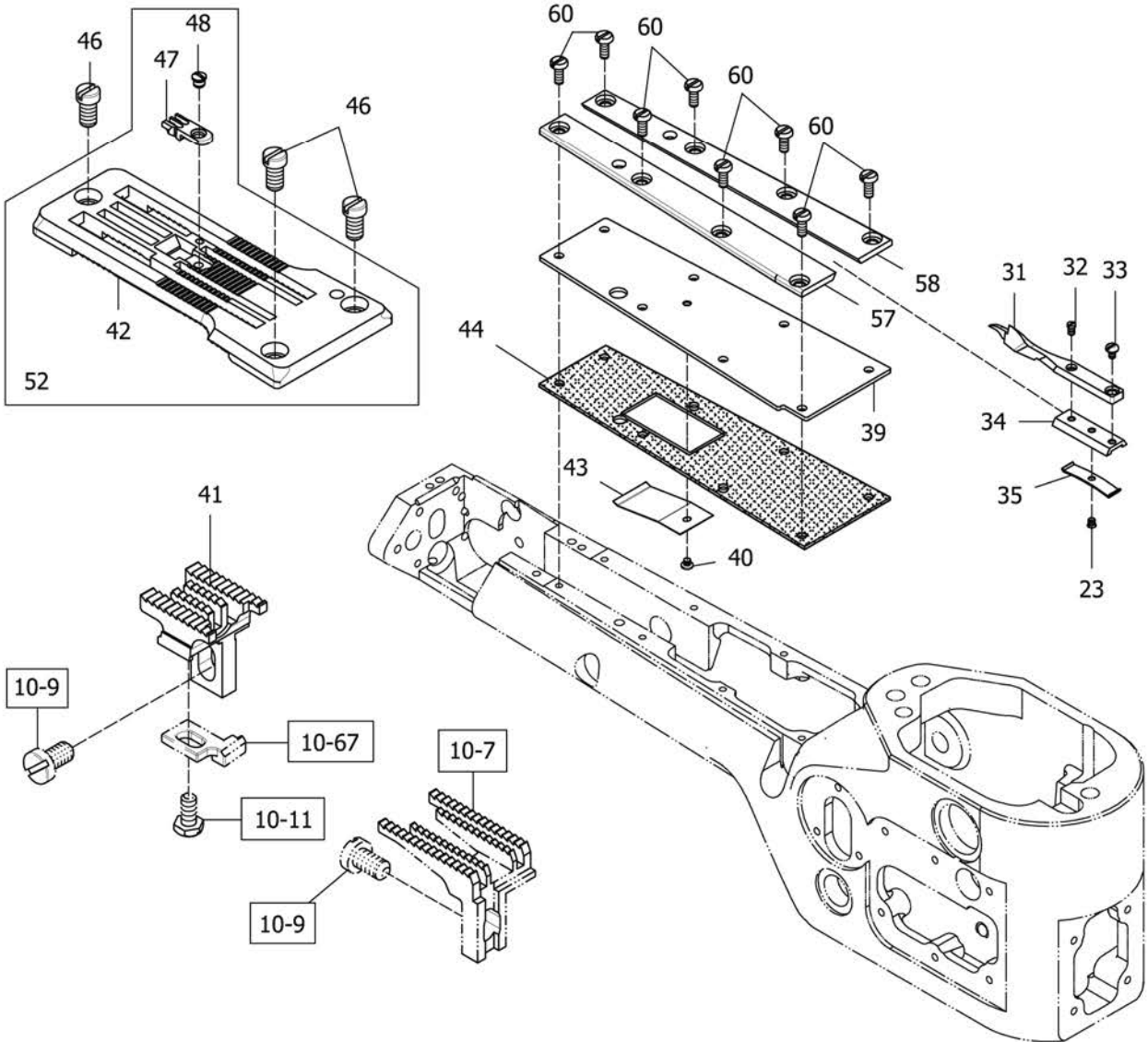
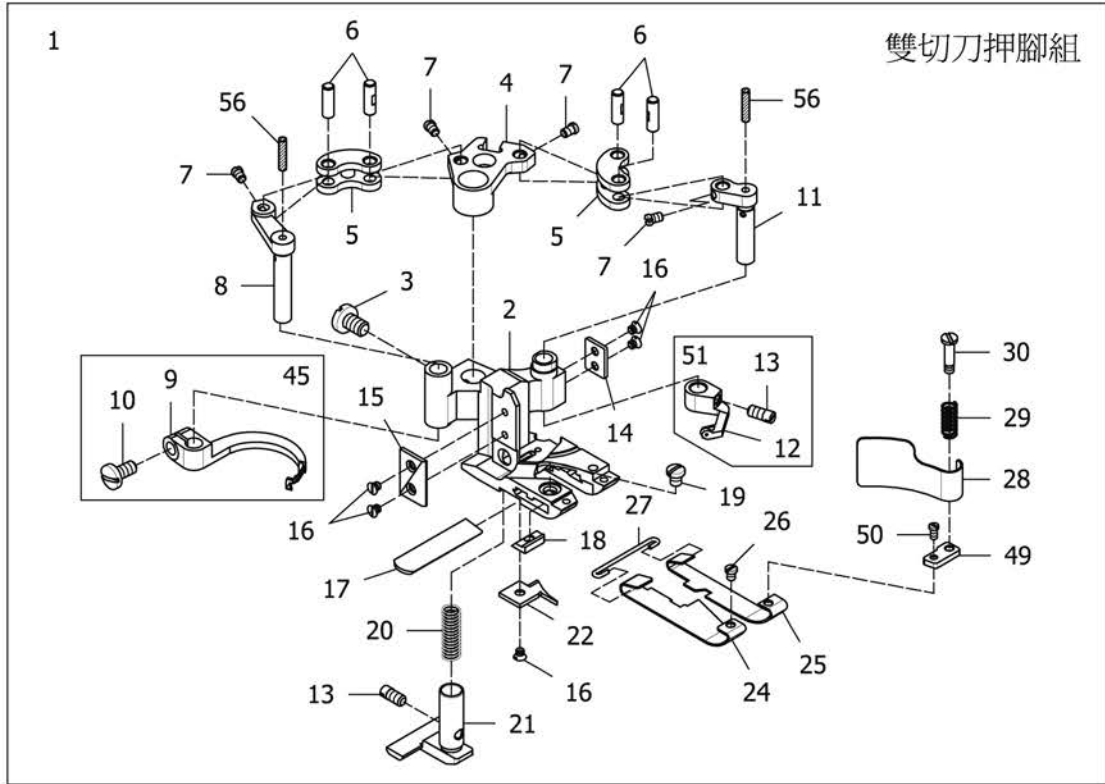

DOUBLE SIDE CUT PRESSER FOOT MECHANISM**雙切押腳機構****18**

Ref.	Parts			Amt.
No.	No.	Description	品名	Req.
1	★	Double Side Cut Presser Foot C. Set.....	雙切押具組.....	1
2	★	Double Side Cut Presser Foot.....	雙切押腳.....	1
3	07400615	Screw (1/64-40X6.3).....	螺絲.....	1
4	★ 07400616	Carrier/Hook Driving Segment.....	上勾針驅動扇形片.....	1
5	★ 07400617	Carrier/Hook Driving Lever Link.....	上勾針驅動連桿.....	2
6	★ 07400618	Link Pin.....	連桿插銷.....	4
7	07400619	Screw (3/32-56X3.3).....	螺絲.....	4
8	★ 07400620	Thread Hook Driving Lever.....	勾針驅動槓桿.....	1
9	★ 07400621MF	Top Cover Thread Hook.....	上飾線勾針(長).....	1
10	07400622	Screw (9/64-40X6.8).....	螺絲.....	1
11	★ 07400623	Top Cover Thread Carrier Driving Lever.....	上飾線托架驅動槓桿.....	1
12	★ 07400624MF	Top Cover Thread Carrier.....	上飾線勾針(短).....	1
13	07400338	Screw (1/8-44X5).....	螺絲.....	2
14	★ 07400626	Presser Foot Attach Piece (Right).....	押腳連接片(右).....	1
15	★ 07400627	Presser Foot Attach Piece (Left).....	押腳連接片(左).....	1
16	07400628	Screw(3/32-56X1.5).....	螺絲.....	5
17	★ 07400629	Lower Knife.....	下切刀片.....	1
18	★ 07400630	Lower Knife Clamp.....	下切刀夾板.....	1
19	07400631	Screw (1/8-44X3.5).....	螺絲.....	1
20	★ 07400632	Yielding Section Spring.....	押具輔助座彈簧.....	1
21	★ 07401821	Yielding Section.....	押具輔助座.....	1
22	★ 07401822	Presser Foot Tongue.....	導布板.....	1
23	07401823	Screw (3/32-56X2).....	螺絲.....	1
24	★ 07401824	Presser Foot Spring Plate (Left).....	押具押板(左).....	1
25	★ 07401825	Presser Foot Spring Plate (Right).....	押具押板(右).....	1
26	07400637	Screw (3/32-56X2.6).....	螺絲.....	1
27	★ 07400638	Spring Plate Holder.....	彈簧片固定座.....	1
28	★ 07401828	Chip Guard.....	切角防護片.....	1
29	★ 07400640	Chip Guard Spring.....	切角防護片彈簧.....	1
30	07400641	Screw (1/8-44X3.4).....	螺絲.....	1
31	★ 07401831	Lap Former Guide.....	導布器.....	1
32	07401832	Screw (3/32-56X3.5).....	螺絲.....	1
33	07401833	Screw (3/32-56X3.9).....	螺絲.....	1
34	★ 07401834	Lap Former Guide Support.....	導布器座.....	1
35	★ 07401835	Lap Former Guide Spring.....	導布器彈簧片.....	1
39	★ 07401839	Sewing Cylinder Cover (Upper).....	下巴蓋板.....	1
40	07400221	Screw (3/32-56X1.8).....	螺絲.....	1

★ 請參照附件1【針距規格表】

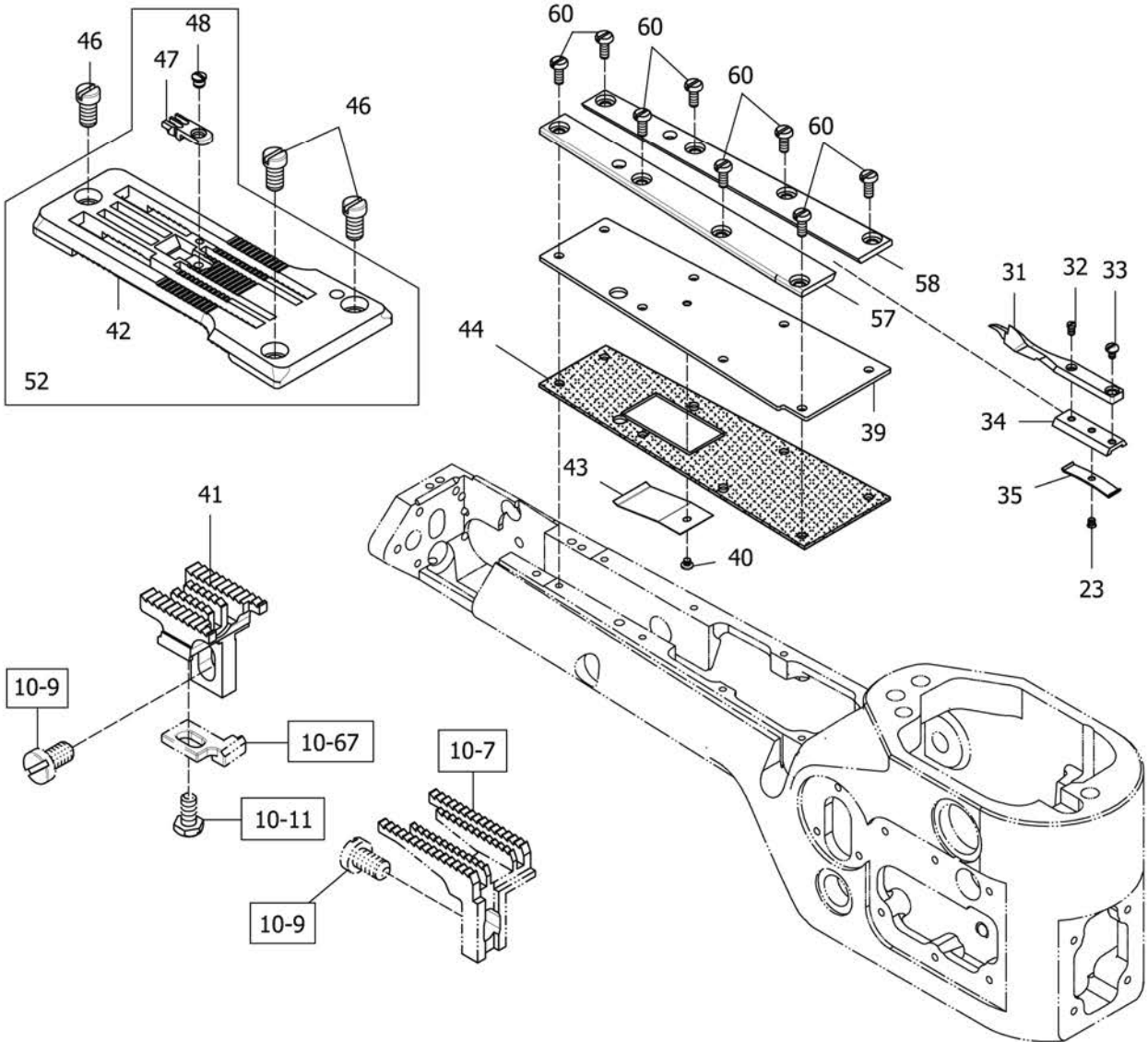
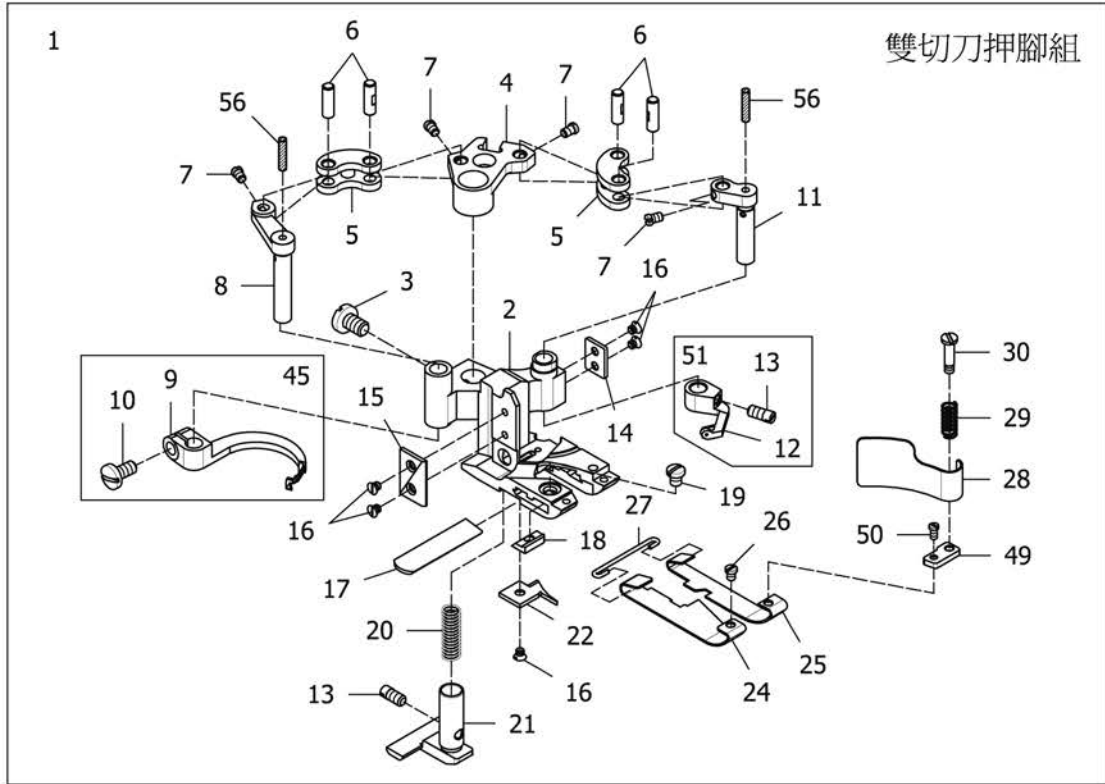

DOUBLE SIDE CUT PRESSER FOOT MECHANISM**雙切押腳機構****18**

Ref.	Parts			Amt.
<u>No.</u>	<u>No.</u>	<u>Description</u>	<u>品 名</u>	<u>Req.</u>
41	★ 07401841	Main Feed Dog.....	雙切後送齒.....	1
42	★	Stitch Plate.....	雙切針板.....	1
43	07400220	Dust Defender (Upper).....	防塵蓋(上).....	1
44	07400217	Seal Gasket.....	止油墊片.....	1
45	07400646MF	Top Cover Thread Hook C.Set.....	上飾線勾針組(長).....	1
46	07400538	Screw (9/64-40X6.4).....	螺絲.....	3
47	★	Stitch Plate Tongue.....	針板舌.....	1
48	07400547	Screw (3/32-56X2).....	螺絲.....	1
49	★ 07400649	Spacer.....	墊塊.....	1
50	07400650	Screw (3/32-56X4.8).....	螺絲.....	1
51	07400647MF	Top Cover Thread Carrier C.Set.....	上飾線勾針組(短).....	1
52	★	Stitch Plate C.Set.....	針板組.....	1
56	★ 07400651	Green Wool.....	綠色毛線.....	2
57	★ 07401857	Lap Former Guide Plate (Left).....	導布器滑軌(左).....	1
58	★ 07401858	Lap Former Guide Plate (Right).....	導布器滑軌(右).....	1
60	07400245	Screw (1/8-44X10).....	螺絲.....	8
	★ 請參照附件1【針距規格表】			

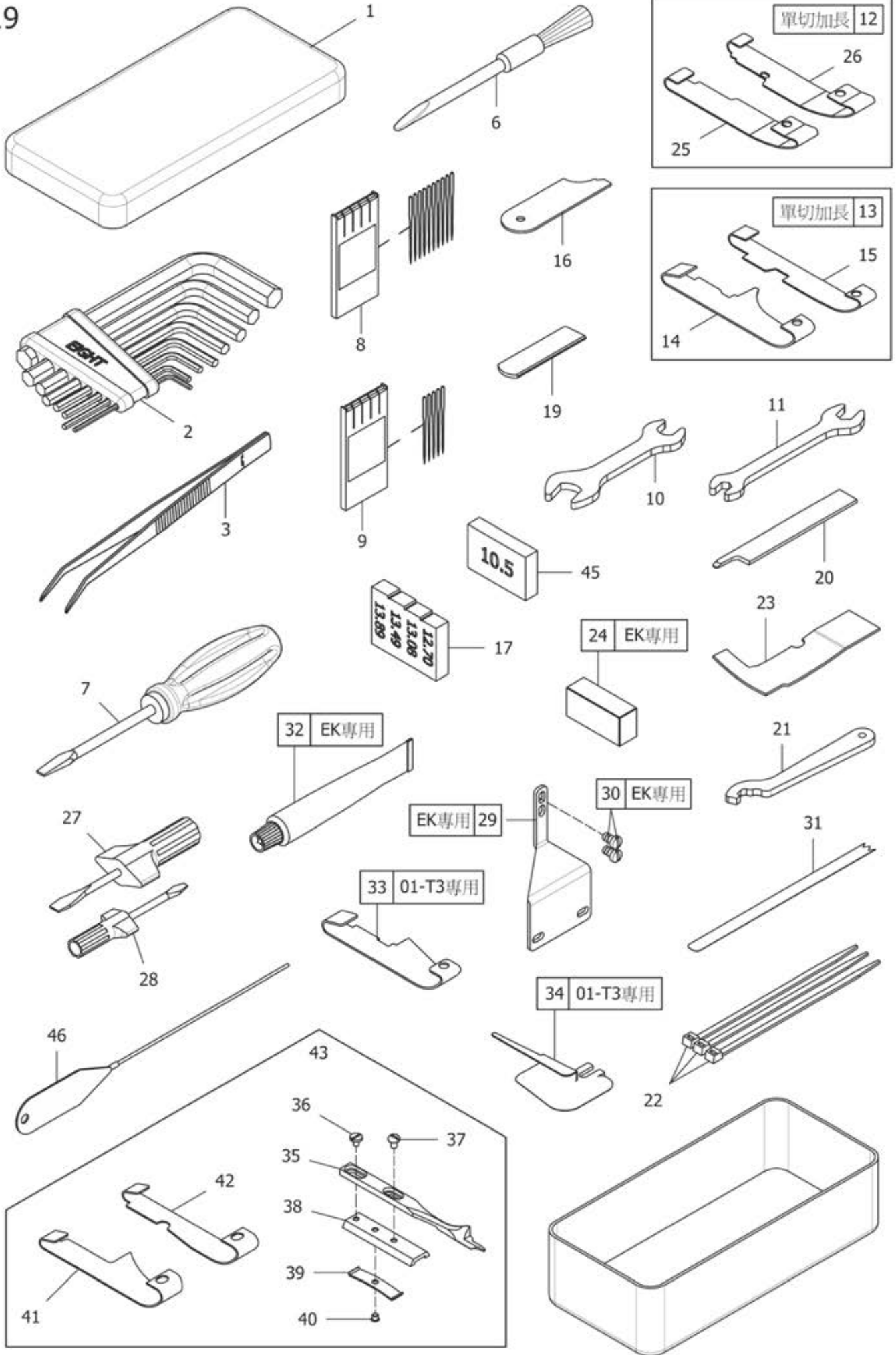

ATTACHMENT BOX**附件盒****19**

Ref.	Parts			Amt.
No.	No.	Description	品名	Req.
1	07873222	Attachment Box.....	附件盒.....	1
2	07401902	Hexagonal Wrench C. Set.....	內六角扳手組.....	1
3	07401903	Thread Tweezers.....	穿線夾.....	1
6	07873226	Hairbrush.....	毛刷.....	1
7	07873218	Screwdriver.....	螺絲起子.....	1
8	★	Needle.....	機針.....	10
9	★	Needle.....	假針.....	5
10	07401910	Wrench.....	扳手.....	1
11	07401911	Wrench.....	扳手.....	1
12	07401912	Presser Foot Spring Plate C. Set (One Side Cut).....	押腳押具組(長)(單切).....	1
13	07401913	Presser Foot Spring Plate C. Set (Double Side C.....	押腳押具組(長)(雙切).....	1
14	07401914	Presser Foot Spring Plate (Left)(One Side Cut).....	押具押板(左)(長)(雙切).....	1
15	07401915	Presser Foot Spring Plate (Right)(One Side Cut.....	押具押板(右)(長)(雙切).....	1
16	07401916	Looper Gauge.....	勾針前後調節扳手.....	1
17A	07401314A	Needle Height Gauge.....	針棒高度調節器.....	1
19	★ 07400629	Lower Knife.....	下切刀片.....	1
20	★ 07400744	Upper Knife.....	上切刀片.....	1
21	07401921	Adjusting Gauge.....	調節扳手.....	1
22	130101003	Ties.....	束線帶.....	3
23	07401923	Looper Gauges.....	下勾針平行定規.....	1
24A	7401924A	Knife Adjustable Bolck.....	調整刀片墊塊(EK專用).....	1
25	07401925	Presser Foot Spring Plate (Left)(Double Side C.....	押具押板(左)(長)(單切).....	1
26	07401926	Presser Foot Spring Plate (Right)(Double Side.....	押具押板(右)(長)(單切).....	1
27	07873216	Screwdriver.....	螺絲起子.....	1
28	07873217	Screwdriver.....	螺絲起子.....	1
29	07401929	Switches Holder.....	電眼架(正面)(EK專用).....	1
30	07870624	Screw (1/8-44X5.7).....	螺絲(一字).....	2
31	07401931	Thread Type.....	導布條器(T5專用).....	1
32	27901502	Grease Tube.....	潤滑脂(EK專用).....	1
33	07401933	Presser Foot Spring Plate (Left).....	押具押板(左)(01-T3專用).....	1
34	07400215	Folder.....	導布器(01-T3專用).....	1
35	07401935	Lap Former Guide.....	導布器.....	1
36	07400314	Screw (3/32-56X3.1).....	螺絲.....	1
37	07401833	Screw (3/32-56X3.9).....	螺絲.....	1
38	07403534	Lap Former Guide Support.....	導布器座.....	1
39	07401835	Lap Former Guide Spring.....	導布器彈簧片.....	1
40	07401823	Screw (3/32-56X2).....	螺絲.....	1
41	07401941	Presser Foot Spring Plate (Left).....	押具押板(左).....	1
42	07401942	Presser Foot Spring Plate (Right).....	押具押板(右).....	1
43	07401943	Adjustable presser Foot Spring.....	可調式押腳.....	1
45	07401319	Needle Height Gauge (For 470.480).....	針棒高度調節器.....	1
46	07411804	Threading Wire.....	穿線鐵絲.....	1

★ 請參照附件1【針距規格表】

ACCESSORIES

附件箱

20

Ref.	Parts			Amt.
<u>No.</u>	<u>No.</u>	<u>Description</u>	<u>品 名</u>	<u>Req.</u>
1	07873301	Oiler.....	油壺.....	1
2	07873302	Funnel.....	漏斗.....	1
3	07402003	Screw C. Set.....	螺絲組.....	1
4	07402004	Washer.....	墊片.....	4
5	07402005	Rubber Cushion.....	避震膠墊.....	4
6	07402006	Spare Parts Book.....	零件本.....	1
7	07873310	Screwdriver.....	螺絲起子.....	1
8	07401728	Thread Stand C. Set.....	線架組(四針六線).....	1
9	07402009	Machine Cover.....	防塵罩.....	1
10	07402010	Oil.....	潤滑油.....	1
14	07402014	Screwdriver.....	螺絲起子.....	1
15	07402015	Screw(3/8-16X32).....	螺絲.....	2
16	07402016	Washer.....	墊片.....	2
17	07402017	Screw C. Set.....	螺絲組.....	1
18	07402018	Supporting Block Rubber Cushion.....	車台固定座避震膠墊.....	1
19	07402019	Supporting Block Rubber Cushion Set.....	車台固定座避震膠墊螺絲組	1
25	07402025	Instruction & Maintenance Book.....	使用說明&維修手冊.....	1
27	07401729	Thread Stand C. Set.....	線架組(五針七線).....	1
28	07402028	Attachment Box.....	附件盒.....	1

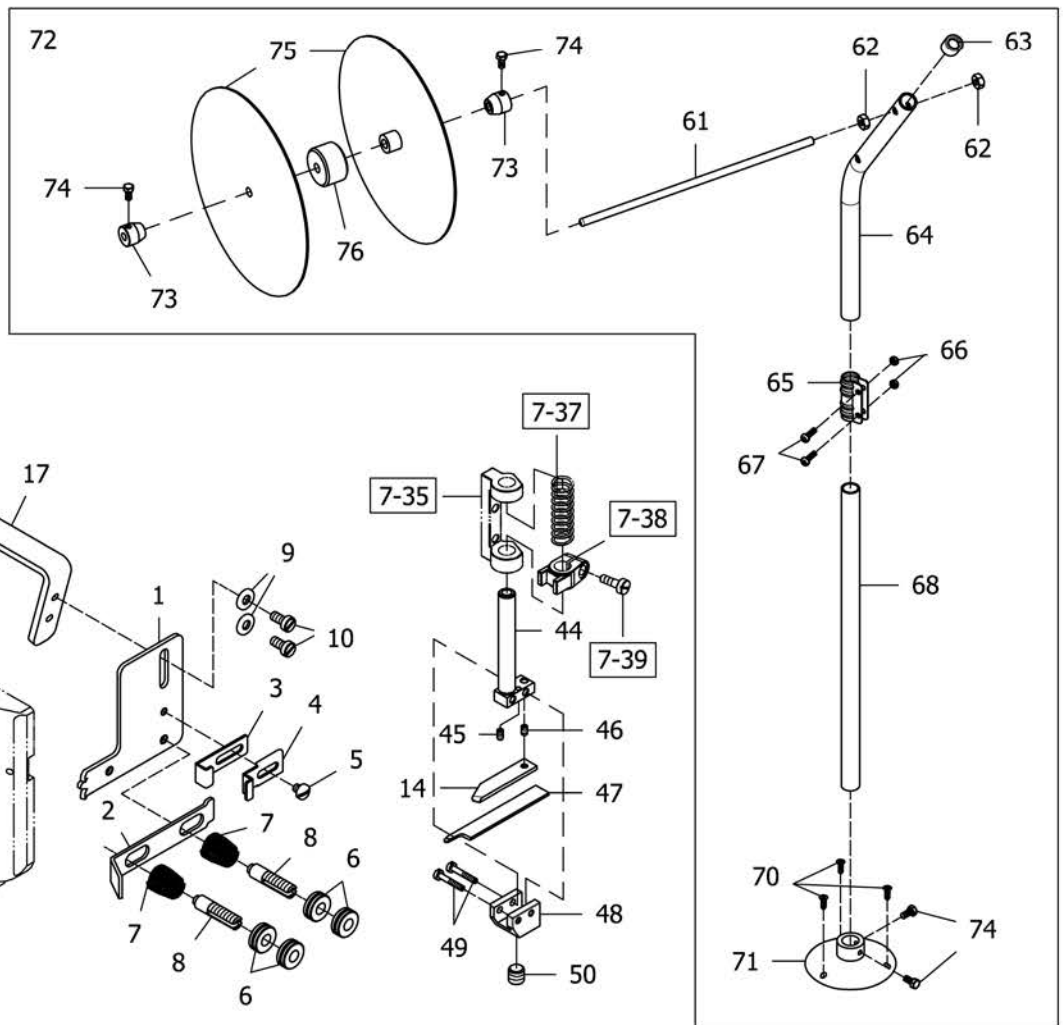
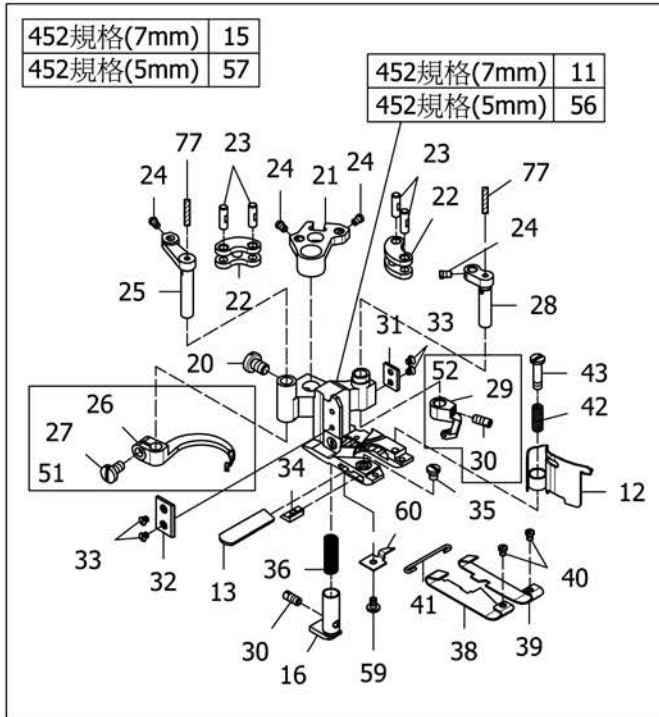

SELECT DEVICE(02-T1)

選擇配備(02-T1)-織帶

21

Ref.	Parts			Amt.
No.	No.	Description	品名	Req.
1	07402101	Tape Holder.....	織帶固定座.....	1
2	07403802	Tape Tension Disc Clamp.....	張力調整夾板.....	1
3	07402103	Tape Thread Guard (Rear).....	過線架(後).....	1
4	07402104	Tape Thread Guard (Front).....	過線架(前).....	1
5	07402105	Screw (9/64-40X4).....	螺絲.....	1
6	07402106	Spring Disc Nut.....	彈簧調整螺帽.....	4
7	07402107	Tape Spring.....	彈簧.....	2
8	07402108	Tension Post.....	張力彈簧支柱.....	2
9	07872903	Wash.....	墊片.....	2
10	07400302	Screw (11/64-40X7.8).....	螺絲.....	2
11	★	Double Side Cut Presser Foot (02-T1) [452(7mm)]	雙切織帶押腳[452(7mm)]...	1
12	★ 07402112	Chip Guard.....	切角防護片.....	1
13	★ 07402113	Lower Knife.....	下切刀.....	1
14	07402114	Knife Support.....	上切刀支架.....	1
15	★	Presser Foot C. Set.....	押具組.....	1
16	★ 07402116	Yielding Section.....	押具輔助座.....	1
17	★ 07402117A	Tape Control Bracket.....	織帶控制架.....	1
20	07400615	Screw (11/64-40X6.3).....	螺絲.....	1
21	★ 07400616	Carrier/Hook Driving Segment.....	上勾針驅動扇形片.....	1
22	★ 07400617	Carrier/Hook Driving Lever Link.....	上勾針驅動連桿.....	2
23	★ 07400618	Link Pin.....	連桿插銷.....	4
24	07400619	Screw (3/32-56X3.3).....	螺絲.....	4
25	★ 07400620	Thread Hook Driving Lever.....	勾針驅動槓桿.....	1
26	★ 07400621MF	Top Cover Thread Hook.....	上飾線勾針(長).....	1
27	07400622	Screw (9/64-40X6.8).....	螺絲.....	1
28	★ 07400623	Top Cover Thread Carrier Driving Lever.....	上飾線托架驅動槓桿.....	1
29	★ MF	Top Cover Thread Carrier.....	上飾線勾針(短).....	1
30	07400338	Screw (1/8-44X5).....	螺絲.....	2
31	★ 07400626	Presser Foot Attach Piece (Right).....	押腳連接片(右).....	1
32	★ 07400627	Presser Foot Attach Piece (Left).....	押腳連接片(左).....	1
33	07400628	Screw(3/32-56X1.5).....	螺絲.....	4
34	★ 07400630	Lower Knife Clamp.....	下切刀夾板.....	1
35	07400631	Screw (1/8-44X3.5).....	螺絲.....	1
36	★ 07400632	Yielding Section Spring.....	押具輔助座彈簧.....	1
38	★ 07401824	Presser Foot Spring Plate (Left).....	押具押板(左).....	1
39	★ 07401825	Presser Foot Spring Plate (Right).....	押具押板(右).....	1
40	07400637	Screw (3/32-56X2.6).....	螺絲.....	2

★ 請參照附件1【針距規格表】

SELECT DEVICE(02-T1)

選擇配備(02-T1)-織帶

21

Ref.	Parts			Amt.
No.	No.	Description	品名	Req.
41	★ 07400638	Spring Plate Holder.....	彈簧片固定座.....	1
42	★ 07400640	Chip Guard Spring.....	切角防護片彈簧.....	1
43	07400641	Screw (1/8-44X3.4).....	螺絲.....	1
44	07400740	Knife Holder Shank.....	上切刀固定座柄.....	1
45	07400741	Screw (3/32-56X3.8).....	螺絲.....	1
46	07400743	Screw (3/32-56X1.2).....	螺絲.....	1
47	★ 07400744	Upper Knife.....	上切刀片.....	1
48	07400745	Knife Holder.....	上刀片固定座.....	1
49	07400746	Screw (3/32-56X7).....	螺絲.....	2
50	07400747	Screw (1/4-40X6).....	螺絲.....	1
51	07400646MF	Top Cover Thread Hook C.Set.....	上飾線勾針組(長).....	1
52	07400647MF	Top Cover Thread Carrier C.Set.....	上飾線勾針組(短).....	1
55	07400168	Screw (M4-0.7X8).....	螺絲.....	2
56	★	Double Side Cut Presser Foot (02-T1) [452(5mm)]	雙切織帶押腳[452(5mm)]...	1
57	★	Presser Foot C. Set.....	押具組.....	1
59	07402159	Screw (3/32-56X4).....	螺絲.....	1
60	★ 07402160	Presser Foot Tongue.....	導布板.....	1
61	07421305	Tape Reel Shaft.....	貼條主軸.....	1
62	07421306	Nut.....	螺帽.....	2
63	07421307	Rubber Column Cap.....	橡膠柱頭蓋.....	1
64	07421308	Tape Column Pipe.....	貼條圓柱管.....	1
65	07421309	Tape Column Pipe Connector.....	接頭.....	1
66	07421310	Nut.....	螺帽.....	2
67	07421311	Screw.....	螺絲.....	2
68	07421312	Fixing Lever.....	固定螺桿.....	1
70	07421314	Wood Screw.....	木螺絲.....	3
71	07421315	Tape Holder.....	貼條固定座.....	1
72	07421333	Tape Reel Holder C.Set.....	貼條架組.....	1
73	07421301	Collar.....	軸環.....	2
74	07421302	Screw.....	螺絲.....	4
75	07402206	Tape Reel.....	貼條盤.....	2
76	07402215	Cushion Block.....	墊塊.....	1
77	★ 07400651	Green Wool.....	綠色毛線.....	2

★ 請參照附件1【針距規格表】

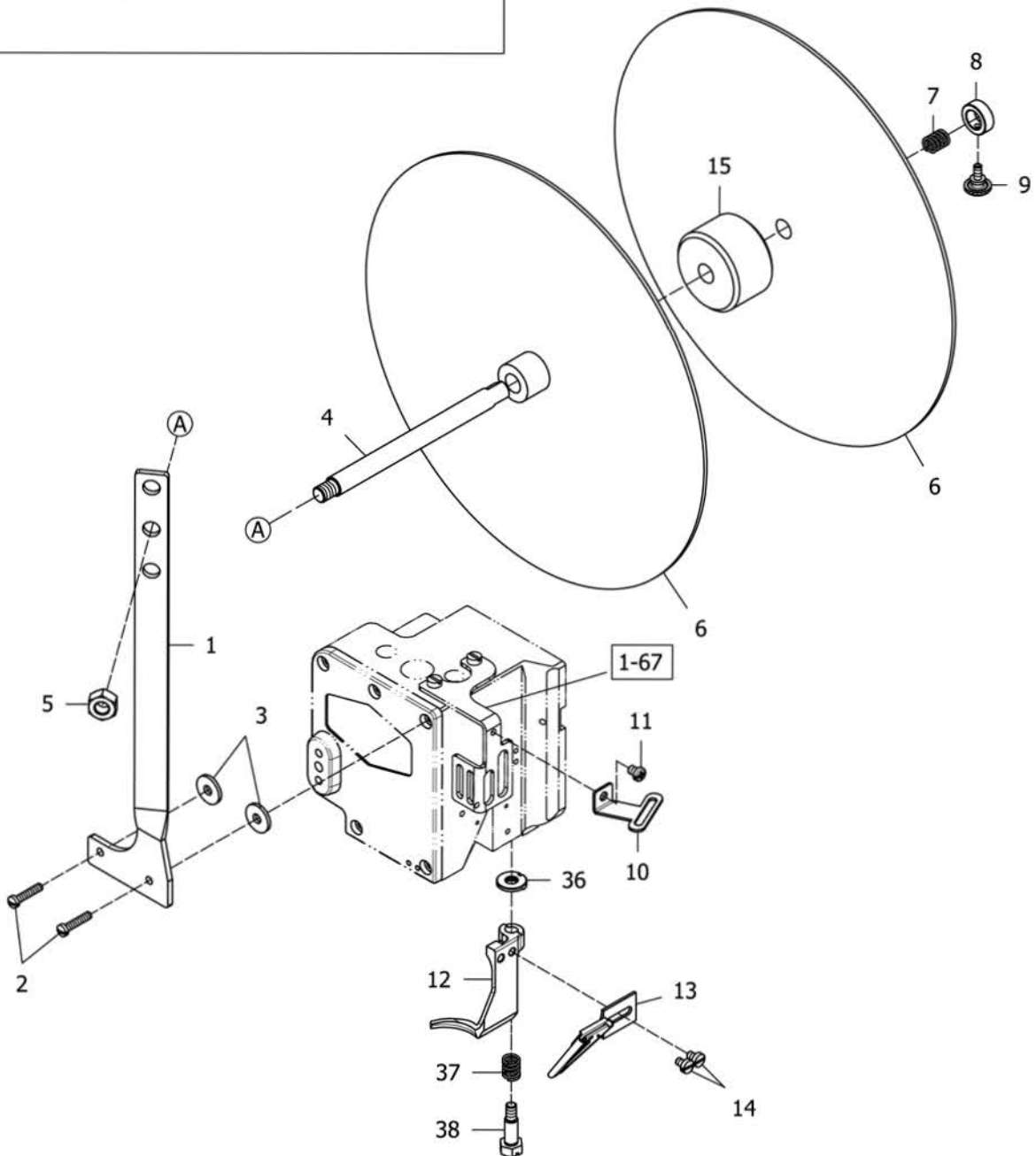
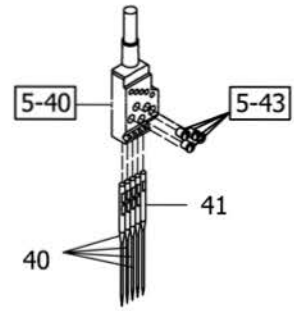
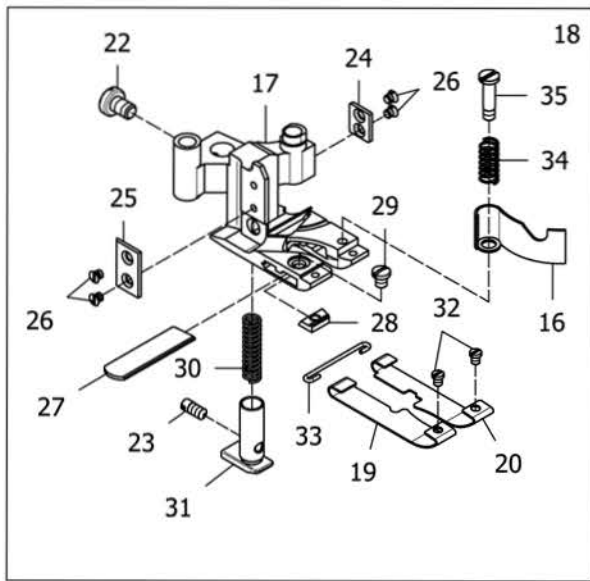

SELECT DEVICE(01-T2)

選擇配備(01-T2)-貼條

22

Ref.	Parts			Amt.
No.	No.	Description	品 名	Req.
1	07402201	Tape Reel Support.....	貼條架.....	1
2	07402202	Screw(9/64-40X17).....	螺絲.....	2
3	07402203	Rubber Cushion.....	橡膠墊片.....	2
4	07402204	Tape Reel Shaft.....	貼條主軸.....	1
5	07402205	Nut.....	螺帽.....	1
6	07402206	Tape Reel.....	貼條盤.....	2
7	07402207	Tape Reel Spring.....	彈簧.....	1
8	07402208	Collar(10X16X6mm).....	軸環.....	1
9	07402209	Screw(9/64-40X7.9).....	螺絲.....	1
10	07402210	Tape Guide.....	織帶導引支架.....	1
11	07402211	Screw(M4-0.7X5).....	螺絲.....	1
12	07402212	Frame Chip Guard.....	導布蓋.....	1
13	07402213	Binder.....	包邊器(喇叭).....	1
14	07402214	Screw(9/64-40X5).....	螺絲.....	2
15	07402215	Cushion Block.....	墊塊.....	1
16	★ 07402216	Chip Guard.....	切角防護片.....	1
17	★	One Side Cut Presser Foot (01-T2).....	單切貼條押腳.....	1
18	★	Presser Foot C. Set	押具組.....	1
19	★ 07402219	Presser Foot Spring Plate (Left).....	押具押板(左).....	1
20	★ 07402220	Presser Foot Spring Plate (Right).....	押具押板(右).....	1
22	07400615	Screw (11/64-40X6.3).....	螺絲.....	1
23	07400338	Screw (1/8-44X5).....	螺絲.....	2
24	★ 07400626	Presser Foot Attach Piece (Right).....	押腳連接片(右).....	1
25	★ 07400627	Presser Foot Attach Piece (Left).....	押腳連接片(左).....	1
26	07400628	Screw(3/32-56X1.5).....	螺絲.....	4
27	★ 07400629	Lower Knife.....	下切刀片.....	1
28	★ 07400630	Lower Knife Clamp.....	下切刀夾板.....	1
29	07400631	Screw (1/8-44X3.5).....	螺絲.....	1
30	★ 07400632	Yielding Section Spring.....	押具輔助座彈簧.....	1
31	★ 07400633	Yielding Section.....	押具輔助座.....	1
32	07400637	Screw (3/32-56X2.6).....	螺絲.....	2
33	★ 07400638	Spring Plate Holder.....	彈簧片固定座.....	1
34	★ 07400640	Chip Guard Spring.....	切角防護片彈簧.....	1
35	07400641	Screw (1/8-44X3.4).....	螺絲.....	1
36	07400182	Frame Chip Guard Washer.....	導布蓋固定墊片.....	1
37	07400183	Frame Chip Guard Spring.....	導布蓋彈簧.....	1
38	07400184	Screw (M5-0.8X8.5).....	螺絲.....	1
40	★	Needle.....	機針.....	4
41	★	Retainer.....	假針.....	1

★ 請參照附件1【針距規格表】

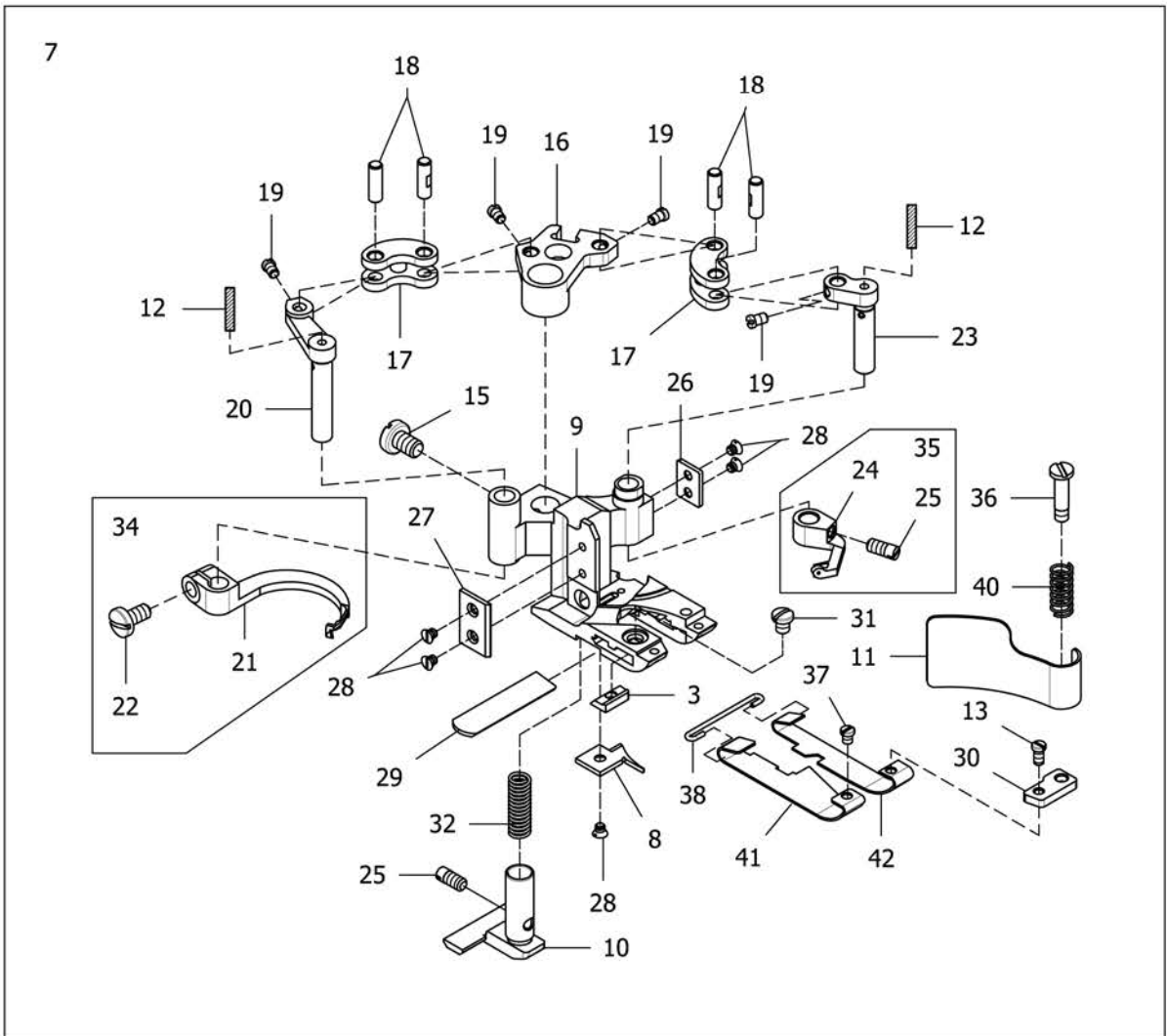
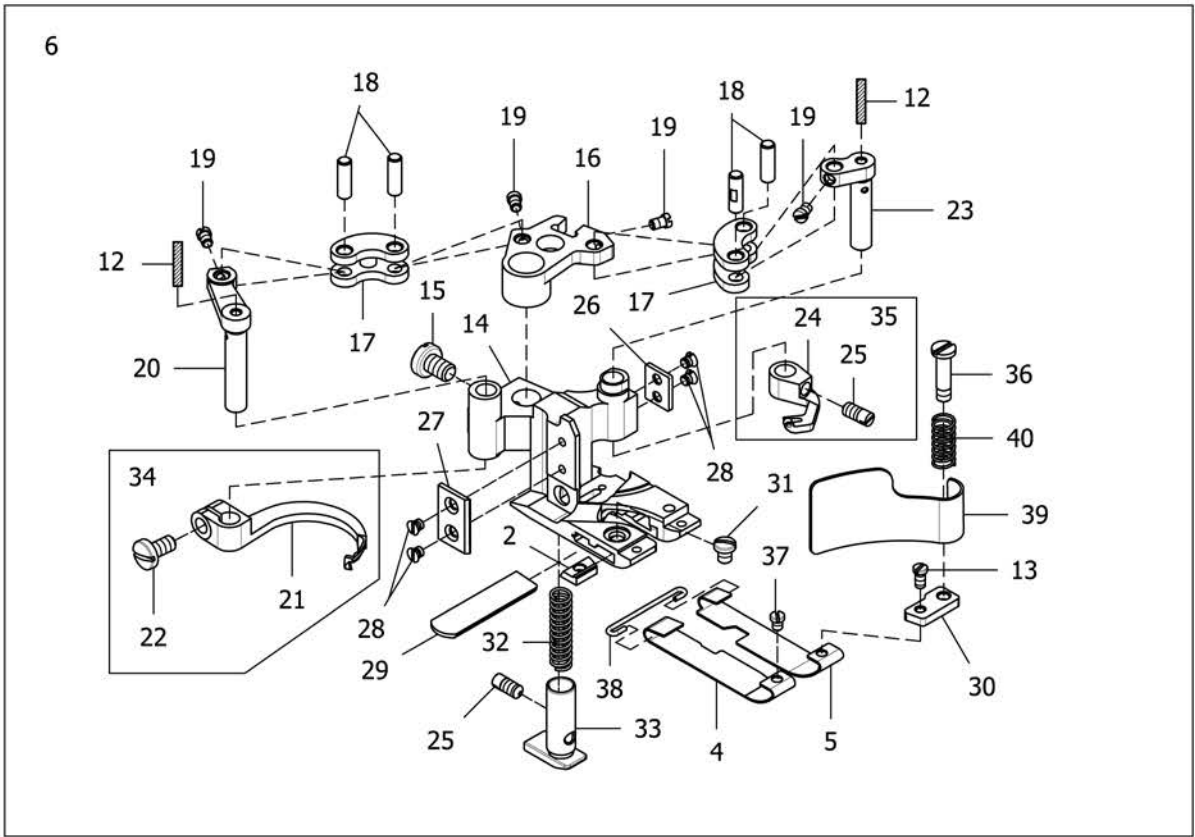

SELECT DEVICE(S)**選擇配備(S)-襪子****23**

Ref.	Parts			Amt.
No.	No.	Description	品名	Req.
2	★ 07402302	Lower Knife Clamp (One Side Cut)	下刀片夾板(單切).....	1
3	★ 07400630	Lower Knife Clamp (Double Side Cut).....	下刀片夾板(雙切).....	1
4	★ 07400635A	Presser Foot Spring Plate (Left).....	押具押板(左)(單切押具組K23-6)...	1
5	★ 07400636A	Presser Foot Spring Plate (Right).....	押具押板(右)(單切押具組K23-6)...	1
6	★	One Side Cut Presser Foot C. Set.....	單切押具組.....	1
7	★	Double Side Cut Presser Foot C. Set.....	雙切押具組.....	1
8	★ 07401822	Presser Foot Tongue.....	導布板.....	1
9	★	Double Side Cut Presser Foot.....	雙切押腳.....	1
10	★ 07401821	Yielding Section.....	押具輔助座.....	1
11	★ 07401828	Chip Guard.....	切角防護片.....	1
12	★ 07400651	Green Wool.....	綠色毛線(單切押具組K23-6)	2
	★ 07400651	Green Wool.....	綠色毛線(雙切押具組K23-7)	2
13	07400650	Screw (3/32-56X4.8).....	螺絲(單切押具組K23-6)....	1
	07400650	Screw (3/32-56X4.8).....	螺絲(雙切押具組K23-7)....	1
14	★	One Side Cut Presser Foot.....	單切押腳.....	1
15	07400615	Screw (11/64-40X6.3).....	螺絲(單切押具組K23-6)....	1
	07400615	Screw (11/64-40X6.3).....	螺絲(雙切押具組K23-7)....	1
16	★ 07400616	Carrier/Hook Driving Segment.....	上勾針驅動扇形片(單切押具組K23-6)	1
	★ 07400616	Carrier/Hook Driving Segment.....	上勾針驅動扇形片(雙切押具組K23-7)	1
17	★ 07400617	Carrier/Hook Driving Lever Link.....	上勾針驅動連桿(單切押具組K23-6)	2
	★ 07400617	Carrier/Hook Driving Lever Link.....	上勾針驅動連桿(雙切押具組K23-7)	2
18	★ 07400618	Link Pin.....	連桿插銷(單切押具組K23-6)	4
	★ 07400618	Link Pin.....	連桿插銷(雙切押具組K23-7)	4
19	07400619	Screw (3/32-56X3.3).....	螺絲(單切押具組K23-6)....	4
	07400619	Screw (3/32-56X3.3).....	螺絲(雙切押具組K23-7)....	4
20	★ 07400620	Thread Hook Driving Lever.....	勾針驅動槓桿(單切押具組K23-6)	1
	★ 07400620	Thread Hook Driving Lever.....	勾針驅動槓桿(雙切押具組K23-7)	1
21	★ 07400621MF	Top Cover Thread Hook.....	上飾線勾針(長)(單切押具組K23-6)	1
	★ 07400621MF	Top Cover Thread Hook.....	上飾線勾針(長)(雙切押具組K23-7)	1
22	07400622	Screw (9/64-40X6.8).....	螺絲(單切押具組K23-6)....	1
	07400622	Screw (9/64-40X6.8).....	螺絲(雙切押具組K23-7)....	1
23	★ 07400623	Top Cover Thread Carrier Driving Lever.....	上飾線托架驅動槓桿(單切押具組K23-6)	1
	★ 07400623	Top Cover Thread Carrier Driving Lever.....	上飾線托架驅動槓桿(雙切押具組K23-7)	1
24	★ MF	Top Cover Thread Carrier.....	上飾線勾針(短)(單切押具組K23-6)	1
	★ MF	Top Cover Thread Carrier.....	上飾線勾針(短)(雙切押具組K23-7)	1
25	07400338	Screw (1/8-44X5).....	螺絲(單切押具組K23-6)....	2
	07400338	Screw (1/8-44X5).....	螺絲(雙切押具組K23-7)....	2

★ 請參照附件1【針距規格表】

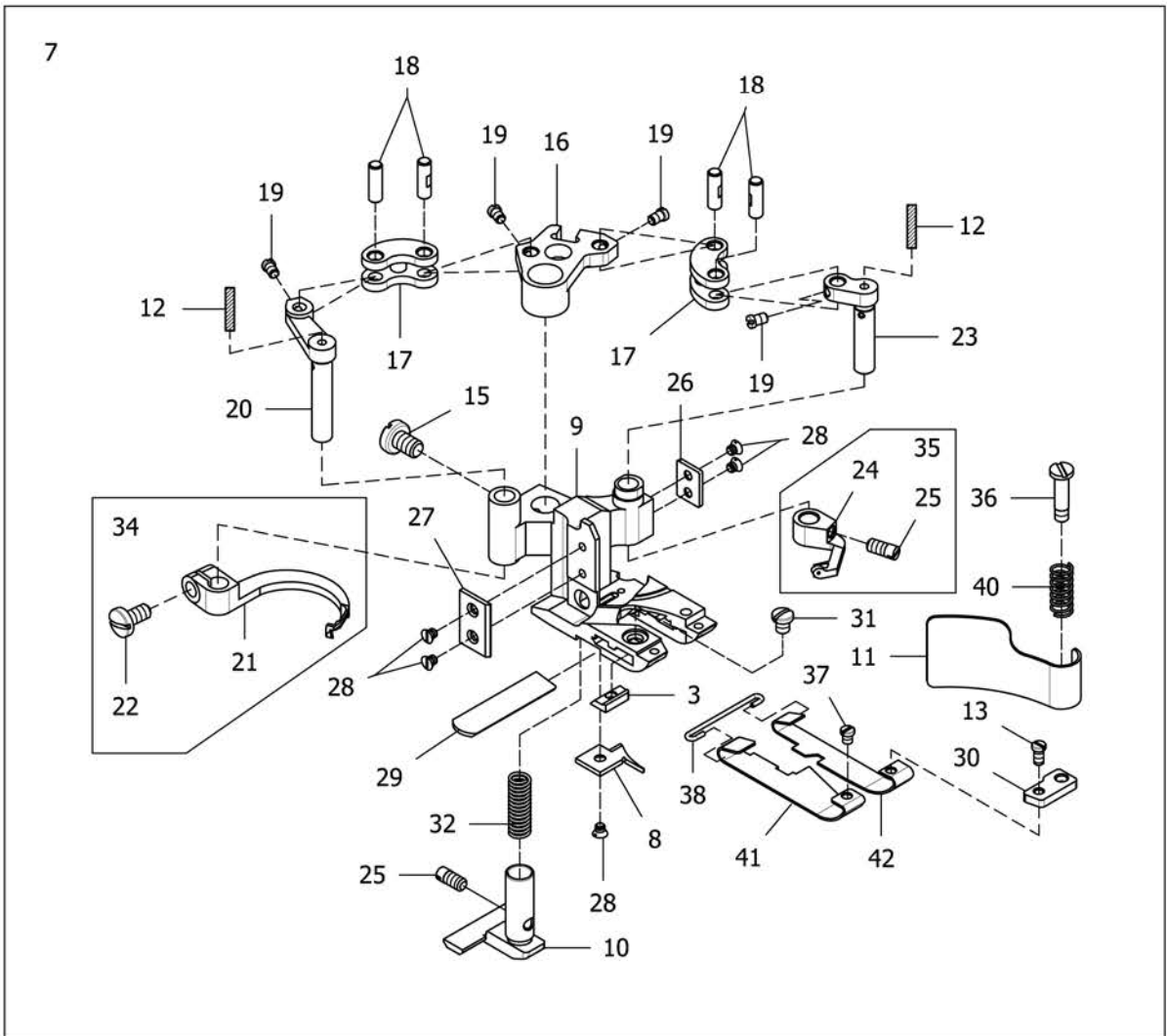
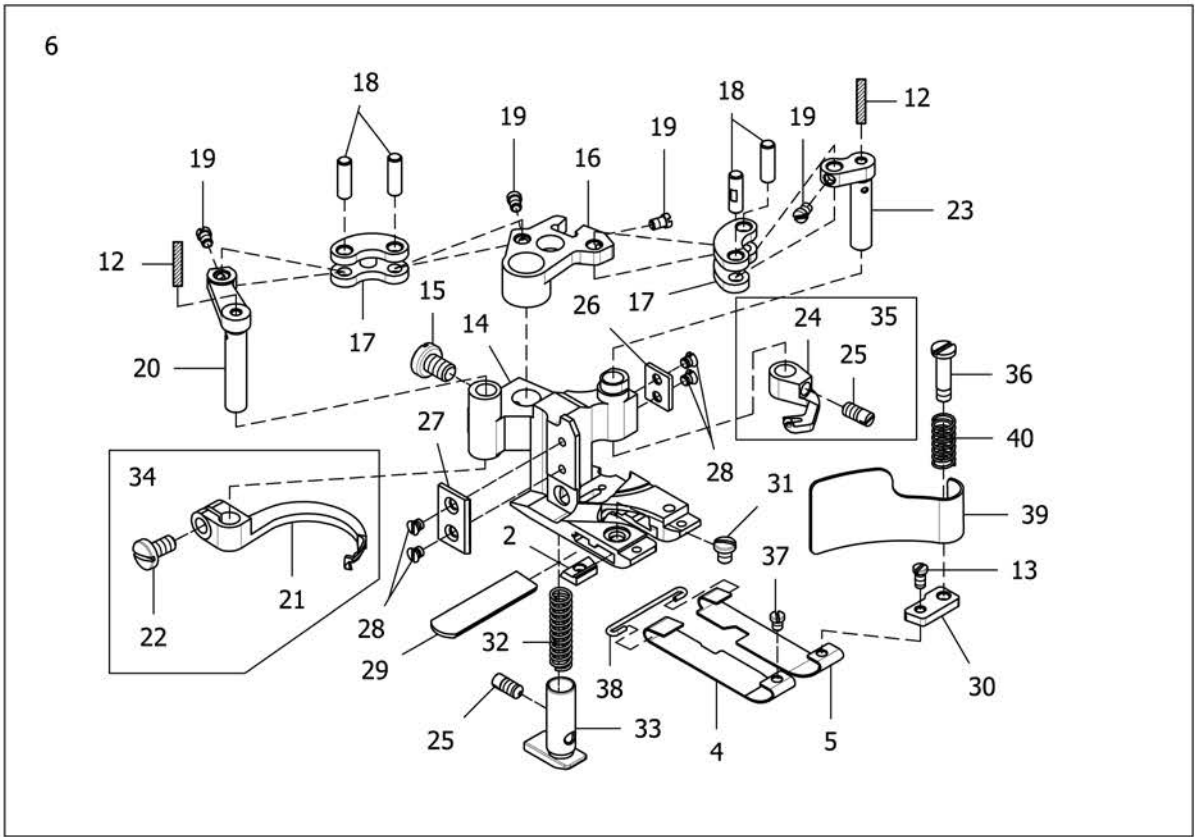

SELECT DEVICE(S)

選擇配備(S)-襪子

Ref.	Parts			Amt.
<u>No.</u>	<u>No.</u>	<u>Description</u>	<u>品 名</u>	<u>Req.</u>
26	★ 07400626	Presser Foot Attach Piece (Right).....	押腳連接片(右)(單切押具組K23-6)	1
	★ 07400626	Presser Foot Attach Piece (Right).....	押腳連接片(右)(雙切押具組K23-7)	1
27	★ 07400627	Presser Foot Attach Piece (Left).....	押腳連接片(左)(單切押具組K23-6)	1
	★ 07400627	Presser Foot Attach Piece (Left).....	押腳連接片(左)(雙切押具組K23-7)	1
28	07400628	Screw(3/32-56X1.5).....	螺絲(單切押具組K23-6)....	4
	07400628	Screw(3/32-56X1.5).....	螺絲(雙切押具組K23-7)....	5
29	★ 07400629	Lower Knife.....	下切刀片(單切押具組K23-6)	1
	★ 07400629	Lower Knife.....	下切刀片(雙切押具組K23-7)	1
30	★ 07400649	Spacer.....	墊塊(單切押具組K23-6)....	1
	★ 07400649	Spacer.....	墊塊(雙切押具組K23-7)....	1
31	07400631	Screw (1/8-44X3.5).....	螺絲(單切押具組K23-6)....	1
	07400631	Screw (1/8-44X3.5).....	螺絲(雙切押具組K23-7)....	1
32	★ 07400632	Yielding Section Spring.....	押腳輔助座彈簧(單切押具組K23-6)	1
	★ 07400632	Yielding Section Spring.....	押腳輔助座彈簧(雙切押具組K23-7)	1
33	★ 07400633	Yielding Section.....	押具輔助座.....	1
34	07400646MF	Top Cover Thread Hook C.Set.....	上飾線勾針組(長)(單切押具組K23-6)	1
	07400646MF	Top Cover Thread Hook C.Set.....	上飾線勾針組(長)(雙切押具組K23-7)	1
35	07400647MF	Top Cover Thread Carrier C.Set.....	上飾線勾針組(短)(單切押具組K23-6)	1
	07400647MF	Top Cover Thread Carrier C.Set.....	上飾線勾針組(短)(雙切押具組K23-7)	1
36	07400641	Screw (1/8-44X3.4).....	螺絲(單切押具組K23-6)....	1
	07400641	Screw (1/8-44X3.4).....	螺絲(雙切押具組K23-7)....	1
37	07400637	Screw (3/32-56X2.6).....	螺絲(單切押具組K23-6)....	1
	07400637	Screw (3/32-56X2.6).....	螺絲(雙切押具組K23-7)....	1
38	★ 07400638	Spring Plate Holder.....	彈簧片固定座(單切押具組K23-6)	1
	★ 07400638	Spring Plate Holder.....	彈簧片固定座(雙切押具組K23-7)	1
39	★ 07400639	Chip Guard.....	切角防護片.....	1
40	★ 07400640	Chip Guard Spring.....	切角防護片彈簧(單切押具組K23-6)	1
	★ 07400640	Chip Guard Spring.....	切角防護片彈簧(雙切押具組K23-7)	1
41	★ 07401824	Presser Foot Spring Plate (Left).....	押具押板(左)(雙切押具組K23-7)...	1
42	★ 07401825	Presser Foot Spring Plate (Right).....	押具押板(右)(雙切押具組K23-7)...	1
	★ 請參照附件1【針距規格表】			

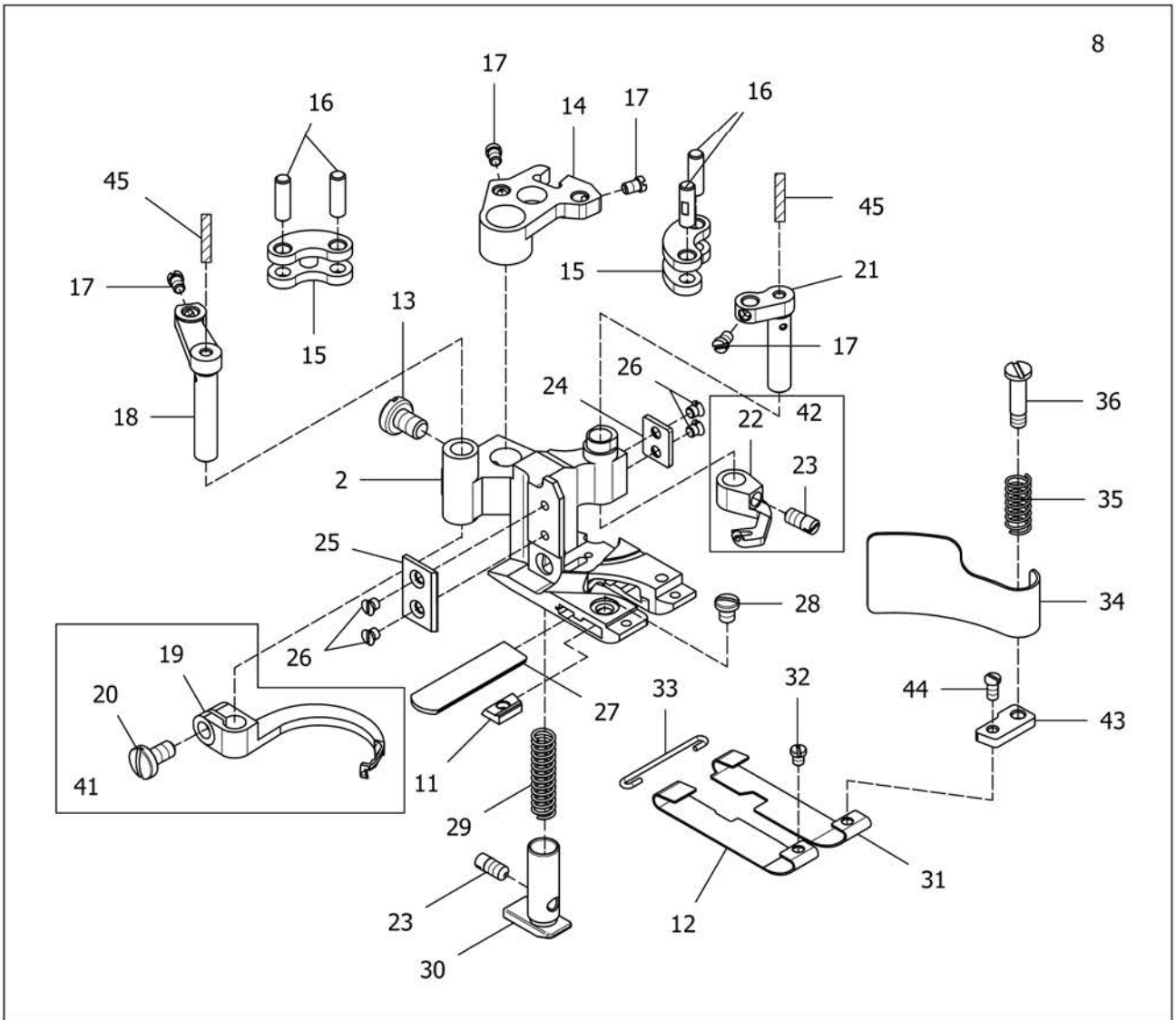
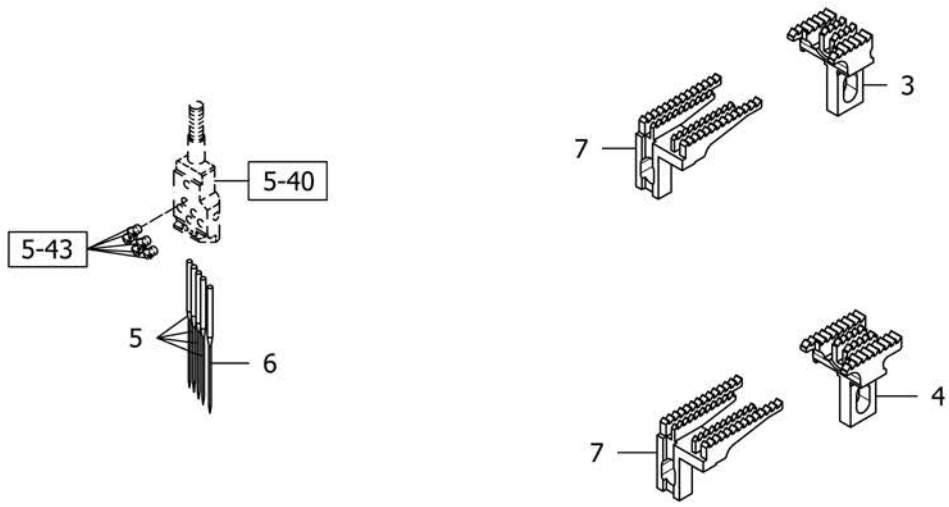

SELECT DEVICE(01-DS)-452.460

選擇配備(01-DS)-潛水衣 **24**

Ref.	Parts			Amt.
No.	No.	Description	品名	Req.
2	★	Presser Foot (01)-452.460.....	專用押腳(01)-規格452.460...	1
3	★ 07402403	Main Feed Dog (One Side Cut).....	後送齒(單切).....	1
4	★ 07402404	Main Feed Dog (Double Side Cut).....	後送齒(雙切).....	1
5	★	Needle.....	機針.....	4
6	★	Retainer.....	假針.....	1
7	★ 07402407	Differential Feed Dog.....	前送齒.....	1
8	★	Presser Foot C. Set	專用押具組.....	1
11	★ 07400630	Lower Knife Clamp.....	下切刀夾板.....	1
12	★ 07400635A	Presser Foot Spring Plate (Left).....	押具押板(左).....	1
13	07400615	Screw (11/64-40X6.3).....	螺絲.....	1
14	★ 07400616	Carrier/Hook Driving Segment.....	上勾針驅動扇形片.....	1
15	★ 07400617	Carrier/Hook Driving Lever Link.....	上勾針驅動連桿.....	2
16	★ 07400618	Link Pin.....	連桿插銷.....	4
17	07400619	Screw (3/32-56X3.3).....	螺絲.....	4
18	★ 07400620	Thread Hook Driving Lever.....	勾針驅動槓桿.....	1
19	★ 07400621MF	Top Cover Thread Hook.....	上飾線勾針(長).....	1
20	07400622	Screw (9/64-40X6.8).....	螺絲.....	1
21	★ 07400623	Top Cover Thread Carrier Driving Lever.....	上飾線托架驅動槓桿.....	1
22	★ MF	Top Cover Thread Carrier.....	上飾線勾針(短).....	1
23	07400338	Screw (1/8-44X5).....	螺絲.....	2
24	★ 07400626	Presser Foot Attach Piece (Right).....	押腳連接片(右).....	1
25	★ 07400627	Presser Foot Attach Piece (Left).....	押腳連接片(左).....	1
26	07400628	Screw(3/32-56X1.5).....	螺絲.....	4
27	★ 07400629	Lower Knife.....	下切刀片.....	1
28	07400631	Screw (1/8-44X3.5).....	螺絲.....	1
29	★ 07400632	Yielding Section Spring.....	押具輔助座彈簧.....	1
30	★ 07400633	Yielding Section.....	押具輔助座.....	1
31	★ 07400636A	Presser Foot Spring Plate (Right).....	押具押板(右).....	1
32	07400637	Screw (3/32-56X2.6).....	螺絲.....	1
33	★ 07400638	Spring Plate Holder.....	彈簧片固定座.....	1
34	★ 07400639	Chip Guard.....	切角防護片.....	1
35	★ 07400640	Chip Guard Spring.....	切角防護片彈簧.....	1
36	07400641	Screw (1/8-44X3.4).....	螺絲.....	1
41	07400646MF	Top Cover Thread Hook C.Set.....	上飾線勾針組(長).....	1
42	07400647MF	Top Cover Thread Carrier C.Set.....	上飾線勾針組(短).....	1
43	★ 07400649	Spacer.....	墊塊.....	1
44	07400650	Screw (3/32-56X4.8).....	螺絲.....	1
45	★ 07400651	Green Wool.....	綠色毛線.....	2

★ 請參照附件1【針距規格表】

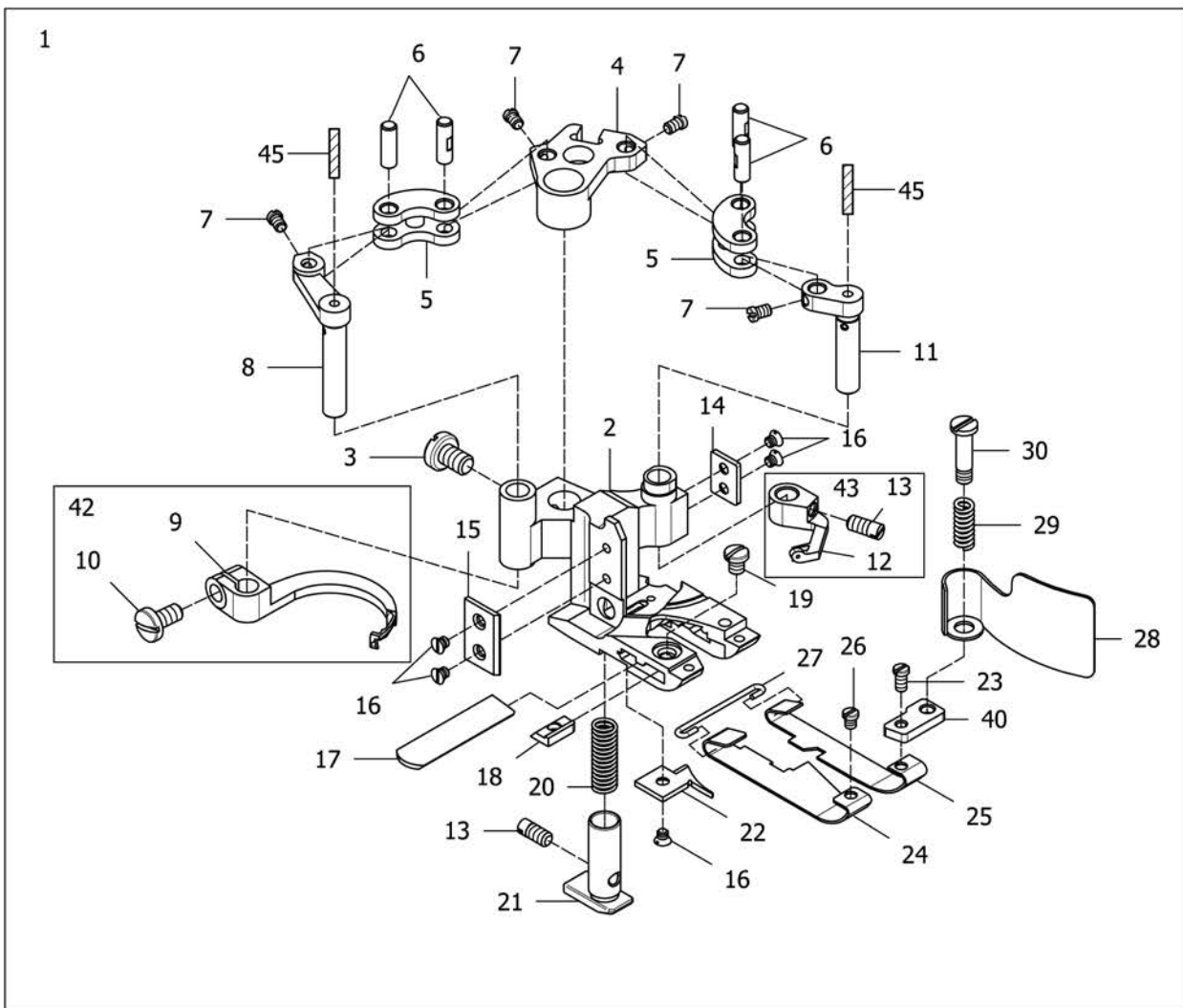
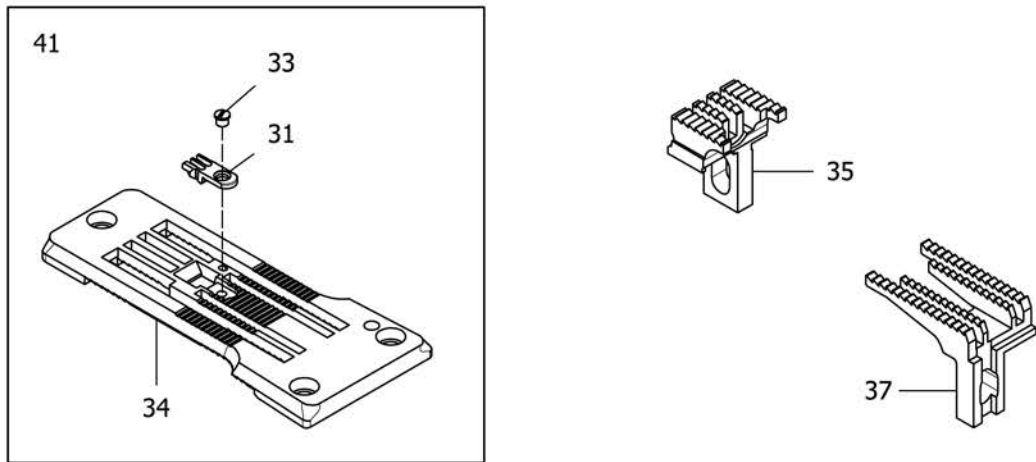

SELECT DEVICE(02R)

Ref.	Parts			Amt.
No.	No.	Description	品名	Req.
1	★	Double Side Cut Presser Foot C. Set.....	雙切押具組.....	1
2	★	Double Side Cut Presser Foot.....	雙切押腳.....	1
3	07400615	Screw (11/64-40X6.3).....	螺絲.....	1
4	★ 07400616	Carrier/Hook Driving Segment.....	上勾針驅動扇形片.....	1
5	★ 07400617	Carrier/Hook Driving Lever Link.....	上勾針驅動連桿.....	2
6	★ 07400618	Link Pin.....	連桿插銷.....	4
7	07400619	Screw (3/32-56X3.3).....	螺絲.....	4
8	★ 07400620	Thread Hook Driving Lever.....	勾針驅動槓桿.....	1
9	★ 07400621MF	Top Cover Thread Hook.....	上飾線勾針(長).....	1
10	07400622	Screw (9/64-40X6.8).....	螺絲.....	1
11	★ 07400623	Top Cover Thread Carrier Driving Lever.....	上飾線托架驅動槓桿.....	1
12	★ MF	Top Cover Thread Carrier.....	上飾線勾針(短).....	1
13	07400338	Screw (1/8-44X5).....	螺絲.....	2
14	★ 07400626	Presser Foot Attach Piece (Right).....	押腳連接片(右).....	1
15	★ 07400627	Presser Foot Attach Piece (Left).....	押腳連接片(左).....	1
16	07400628	Screw(3/32-56X1.5).....	螺絲.....	5
17	★ 07400629	Lower Knife.....	下切刀片.....	1
18	★ 07400630	Lower Knife Clamp.....	下切刀夾板.....	1
19	07400631	Screw (1/8-44X3.5).....	螺絲.....	1
20	★ 07400632	Yielding Section Spring.....	押具輔助座彈簧.....	1
21	★ 07402116	Yielding Section.....	押具輔助座.....	1
22	★ 07401822	Presser Foot Tongue.....	導布板.....	1
23	07400650	Screw (3/32-56X4.8).....	螺絲.....	1
24	★ 07401824	Presser Foot Spring Plate (Left).....	押具押板(左).....	1
25	★ 07401825	Presser Foot Spring Plate (Right).....	押具押板(右).....	1
26	07400637	Screw (3/32-56X2.6).....	螺絲.....	1
27	★ 07400638	Spring Plate Holder.....	彈簧片固定座.....	1
28	★ 07401828	Chip Guard.....	切角防護片.....	1
29	★ 07400640	Chip Guard Spring.....	切角防護片彈簧.....	1
30	07400641	Screw (1/8-44X3.4).....	螺絲.....	1
31	★	Stitch Plate Tongue.....	針板舌.....	1
33	07400547	Screw (3/32-56X2).....	螺絲.....	1
34	★	Stitch Plate (For Single Cutter Only).....	針板(限用單切).....	1
35	★ 07401008	Main Feed Dog (For Single Cutter Only).....	後送齒(限用單切).....	1
37	★ 07401007	Differential Feed Dog.....	前送齒.....	1
40	★ 07400649	Spacer.....	墊塊.....	1
41	★	Stitch Plate C.Set (For Single Cutter Only).....	針板組(限用單切).....	1
42	07400646MF	Top Cover Thread Hook C.Set.....	上飾線勾針組(長).....	1
43	07400647MF	Top Cover Thread Carrier C.Set.....	上飾線勾針組(短).....	1
45	★ 07400651	Green Wool.....	綠色毛線.....	2

★ 請參照附件1【針距規格表】

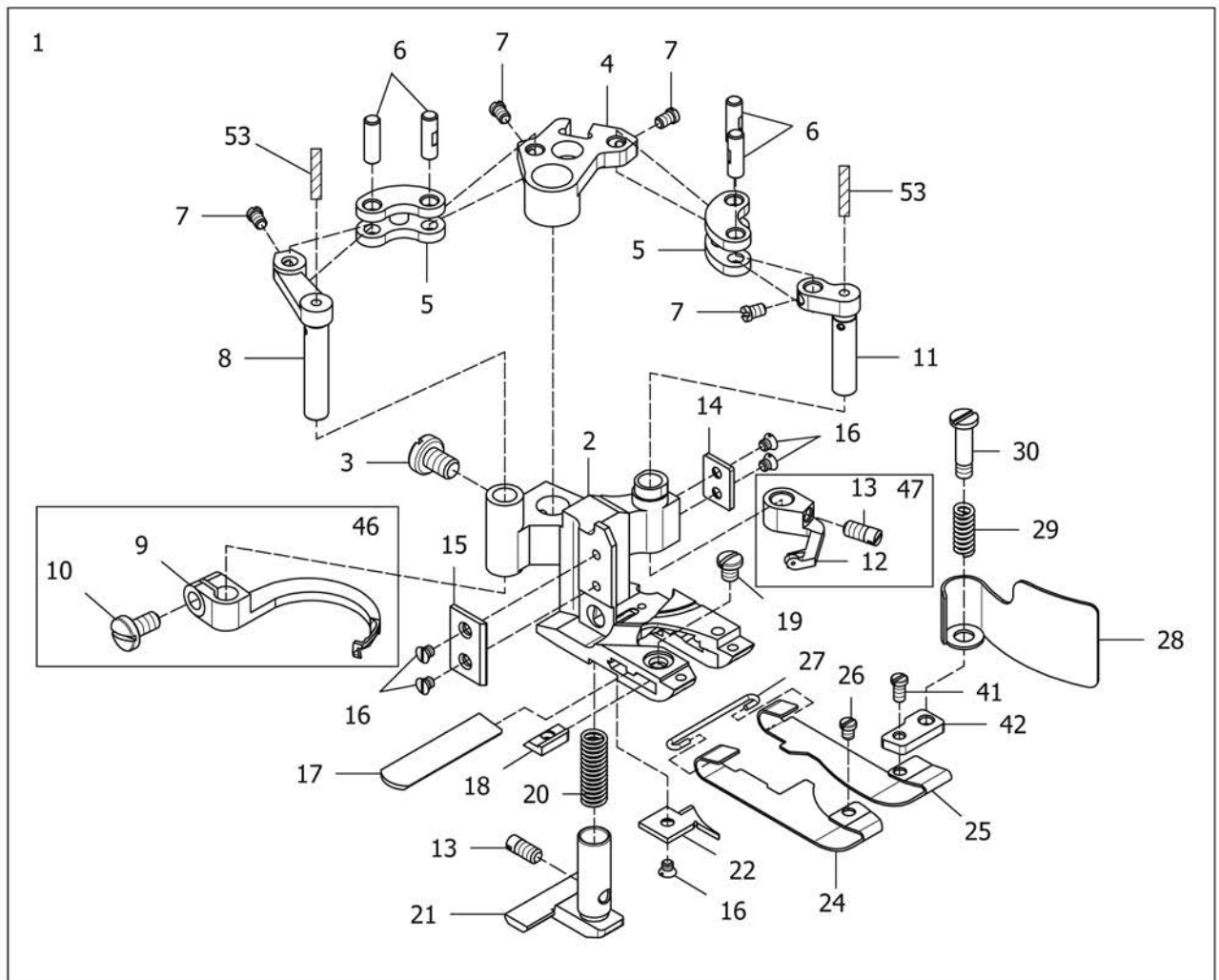
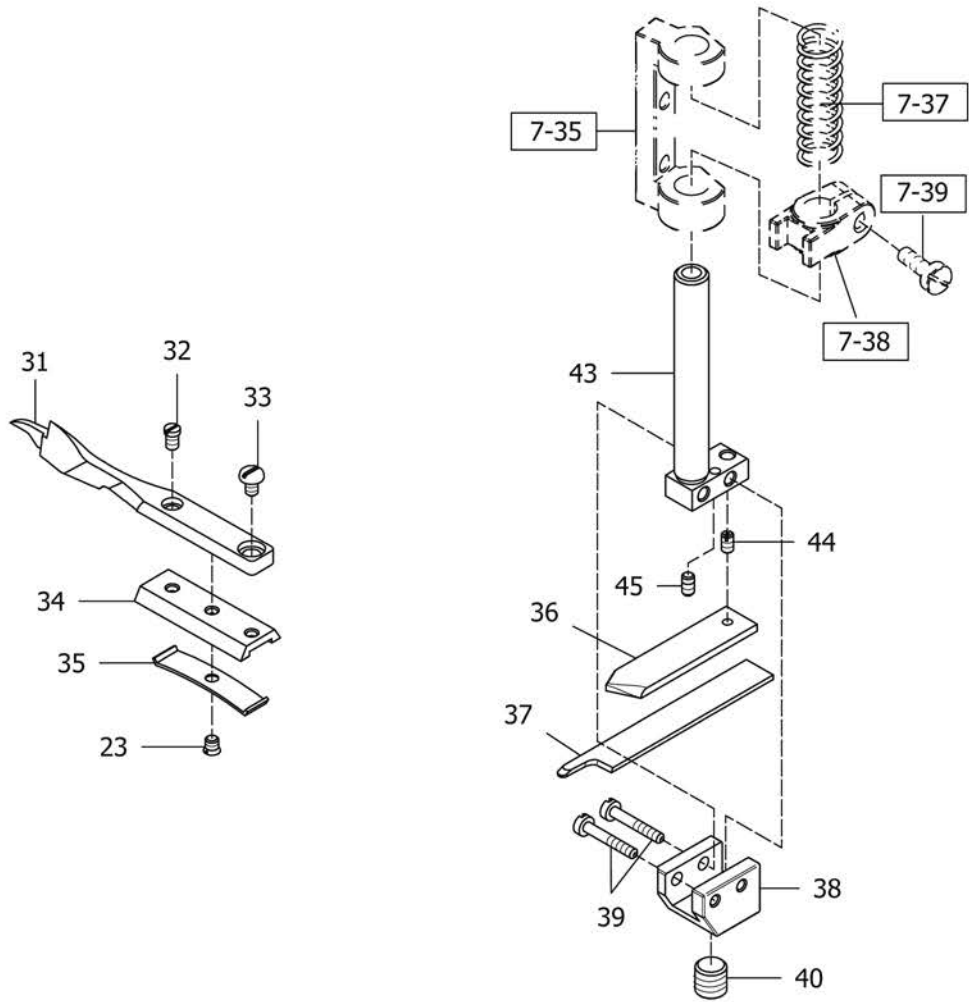

SELECT DEVICE(02H)

Ref.	Parts			Amt.
No.	No.	Description	品名	Req.
1	★	Double Side Cut Presser Foot C. Set.....	雙切押具組.....	1
2	★	Double Side Cut Presser Foot (02H).....	雙切包縫過骨押腳.....	1
3	07400615	Screw (11/64-40X6.3).....	螺絲.....	1
4	★ 07400616	Carrier/Hook Driving Segment.....	上勾針驅動扇形片.....	1
5	★ 07400617	Carrier/Hook Driving Lever Link.....	上勾針驅動連桿.....	2
6	★ 07400618	Link Pin.....	連桿插銷.....	4
7	07400619	Screw (3/32-56X3.3).....	螺絲.....	4
8	★ 07400620	Thread Hook Driving Lever.....	勾針驅動槓桿.....	1
9	★ 07400621MF	Top Cover Thread Hook.....	上飾線勾針(長).....	1
10	07400622	Screw (9/64-40X6.8).....	螺絲.....	1
11	★ 07400623	Top Cover Thread Carrier Driving Lever.....	上飾線托架驅動槓桿.....	1
12	★ MF	Top Cover Thread Carrier.....	上飾線勾針(短).....	1
13	07400338	Screw (1/8-44X5).....	螺絲.....	2
14	★ 07400626	Presser Foot Attach Piece (Right).....	押腳連接片(右).....	1
15	★ 07400627	Presser Foot Attach Piece (Left).....	押腳連接片(左).....	1
16	07400628	Screw(3/32-56X1.5).....	螺絲.....	5
17	★ 07402617	Lower Knife.....	下切刀片.....	1
18	★ 07400630	Lower Knife Clamp.....	下切刀夾板.....	1
19	07400631	Screw (1/8-44X3.5).....	螺絲.....	1
20	★ 07400632	Yielding Section Spring.....	押具輔助座彈簧.....	1
21	★ 07401821	Yielding Section.....	押具輔助座.....	1
22	★ 07401822	Presser Foot Tongue.....	導布板.....	1
23	07401823	Screw (3/32-56X2).....	螺絲.....	1
24	★ 07402624	Presser Foot Spring Plate (Left).....	押具押板(左).....	1
25	★ 07402625	Presser Foot Spring Plate (Right).....	押具押板(右).....	1
26	07400637	Screw (3/32-56X2.6).....	螺絲.....	1
27	★ 07400638	Spring Plate Holder.....	彈簧片固定座.....	1
28	★ 07401828	Chip Guard.....	切角防護片.....	1
29	★ 07400640	Chip Guard Spring.....	切角防護片彈簧.....	1
30	07400641	Screw (1/8-44X3.4).....	螺絲.....	1
31	★ 07402631	Lap Former Guide.....	導布器.....	1
32	07401832	Screw (3/32-56X3.5).....	螺絲.....	1
33	07401833	Screw (3/32-56X3.9).....	螺絲.....	1
34	07401834	Lap Former Guide Support.....	導布器座.....	1
35	07401835	Lap Former Guide Spring.....	導布器彈簧片.....	1
36	07402636	Knife Support.....	上切刀支架.....	1
37	★ 07402637	Upper Knife.....	上刀片.....	1
38	07402638	Knife Holder.....	上刀片固定座.....	1
39	07402639	Screw (3/32-56X8).....	螺絲.....	2

★ 請參照附件1【針距規格表】

SELECT DEVICE(02H)選擇配備(02H)-包縫過骨/特厚刷毛 **26**

Ref.	Parts			Amt.
<u>No.</u>	<u>No.</u>	<u>Description</u>	<u>品 名</u>	<u>Req.</u>
40	07400747	Screw (1/4-40X6).....	螺絲.....	1
41	07400650	Screw (3/32-56X4.8).....	螺絲.....	1
42	★ 07400649	Spacer.....	墊塊.....	1
43	07402643	Knife Holder Shank.....	上切刀固定座柄.....	1
44	07400743	Screw (3/32-56X1.2).....	螺絲.....	1
45	07400741	Screw (3/32-56X3.8).....	螺絲.....	1
46	07400646MF	Top Cover Thread Hook C.Set.....	上飾線勾針組(長).....	1
47	07400647MF	Top Cover Thread Carrier C.Set.....	上飾線勾針組(短).....	1
53	★ 07400651	Green Wool.....	綠色毛線.....	2
	★ 請參照附件1【針距規格表】			

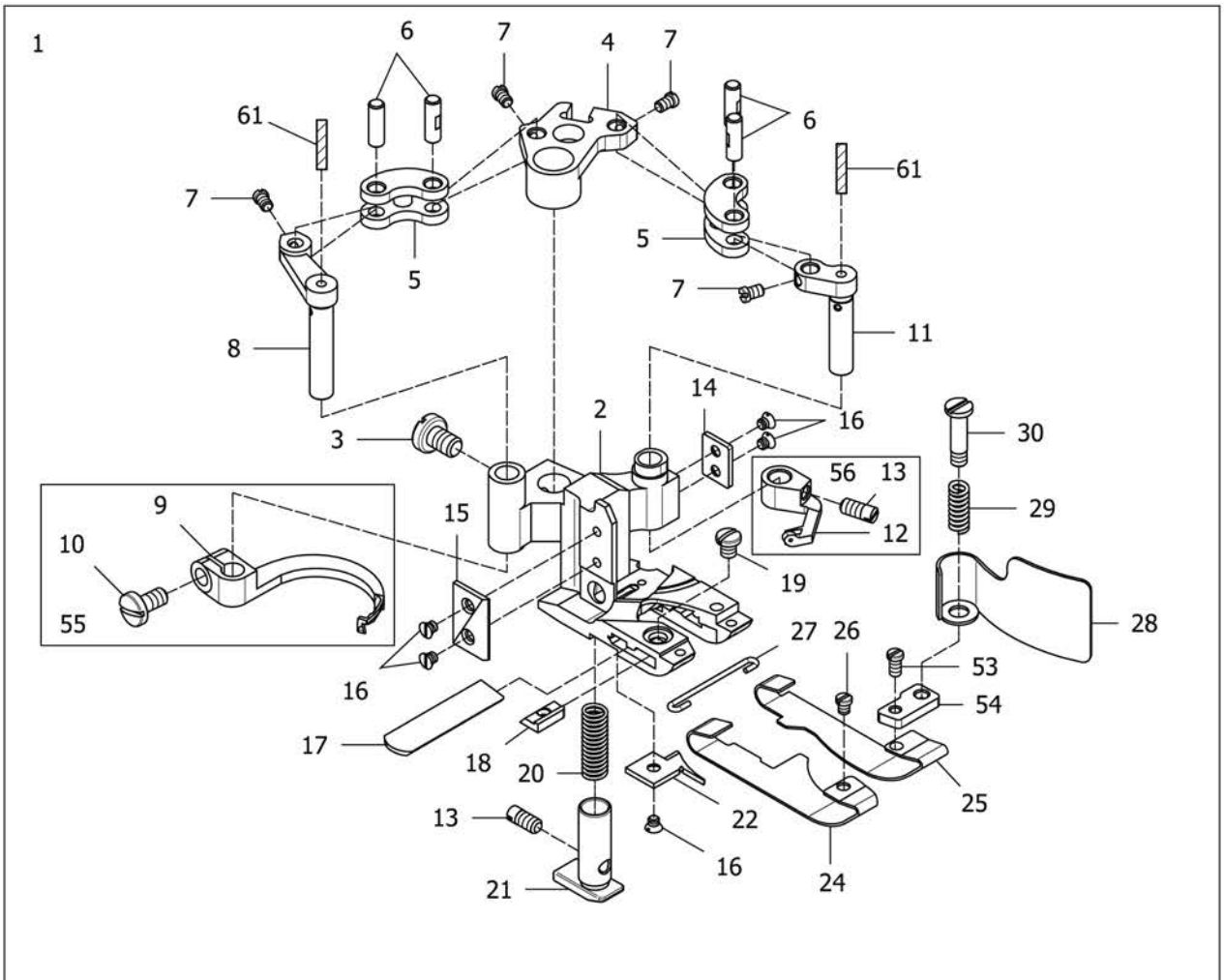
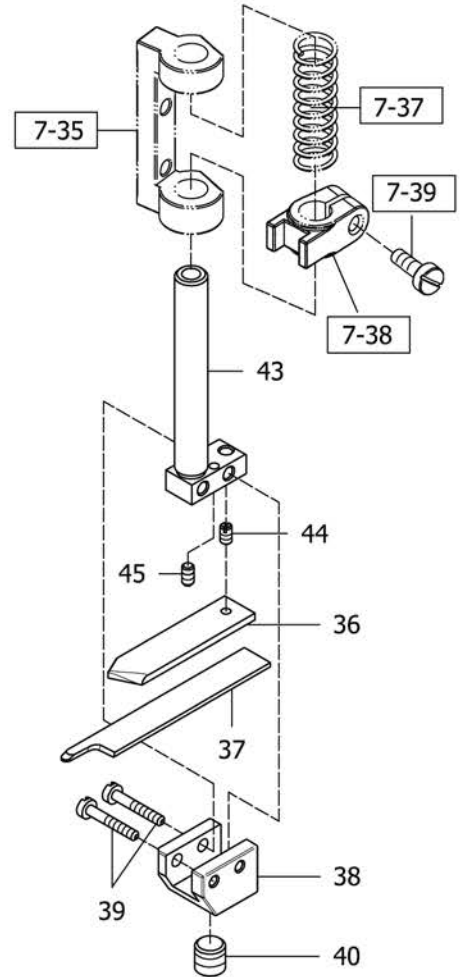
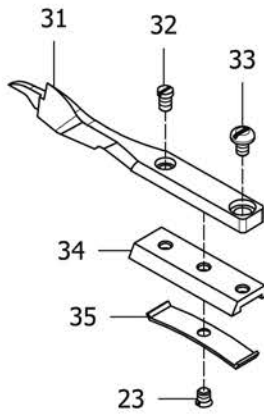
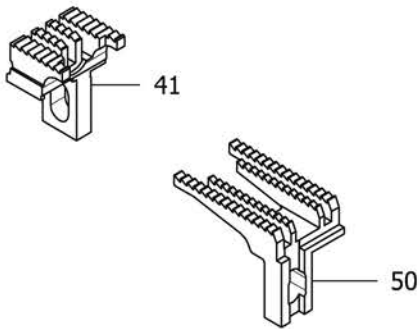
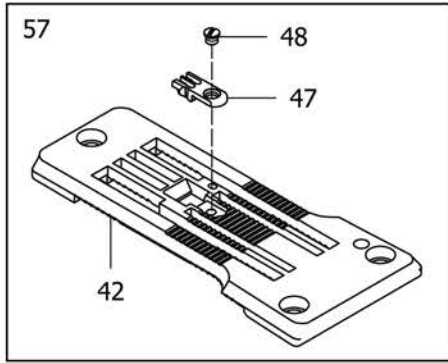

SELECT DEVICE(02RH)

Ref.	Parts			Amt.
No.	No.	Description	品名	Req.
1	★	Double Side Cut Presser Foot C. Set.....	雙切押具組.....	1
2	★	Double Side Cut Presser Foot (02H).....	雙切包縫過骨押腳.....	1
3	07400615	Screw (11/64-40X6.3).....	螺絲.....	1
4	★ 07400616	Carrier/Hook Driving Segment.....	上勾針驅動扇形片.....	1
5	★ 07400617	Carrier/Hook Driving Lever Link.....	上勾針驅動連桿.....	2
6	★ 07400618	Link Pin.....	連桿插銷.....	4
7	07400619	Screw (3/32-56X3.3).....	螺絲.....	4
8	★ 07400620	Thread Hook Driving Lever.....	勾針驅動槓桿.....	1
9	★ 07400621MF	Top Cover Thread Hook.....	上飾線勾針(長).....	1
10	07400622	Screw (9/64-40X6.8).....	螺絲.....	1
11	★ 07400623	Top Cover Thread Carrier Driving Lever.....	上飾線托架驅動槓桿.....	1
12	★ MF	Top Cover Thread Carrier.....	上飾線勾針(短).....	1
13	07400338	Screw (1/8-44X5).....	螺絲.....	2
14	★ 07400626	Presser Foot Attach Piece (Right).....	押腳連接片(右).....	1
15	★ 07400627	Presser Foot Attach Piece (Left).....	押腳連接片(左).....	1
16	07400628	Screw(3/32-56X1.5).....	螺絲.....	5
17	★ 07402617	Lower Knife.....	下切刀片.....	1
18	★ 07400630	Lower Knife Clamp.....	下切刀夾板.....	1
19	07400631	Screw (1/8-44X3.5).....	螺絲.....	1
20	★ 07400632	Yielding Section Spring.....	押具輔助座彈簧.....	1
21	★ 07402116	Yielding Section.....	押具輔助座.....	1
22	★ 07401822	Presser Foot Tongue.....	導布板.....	1
23	07401823	Screw (3/32-56X2).....	螺絲.....	1
24	★ 07402624	Presser Foot Spring Plate (Left).....	押具押板(左).....	1
25	★ 07402625	Presser Foot Spring Plate (Right).....	押具押板(右).....	1
26	07400637	Screw (3/32-56X2.6).....	螺絲.....	1
27	★ 07400638	Spring Plate Holder.....	彈簧片固定座.....	1
28	★ 07401828	Chip Guard.....	切角防護片.....	1
29	★ 07400640	Chip Guard Spring.....	切角防護片彈簧.....	1
30	07400641	Screw (1/8-44X3.4).....	螺絲.....	1
31	★ 07402631	Lap Former Guide.....	導布器.....	1
32	07401832	Screw (3/32-56X3.5).....	螺絲.....	1
33	07401833	Screw (3/32-56X3.9).....	螺絲.....	1
34	07401834	Lap Former Guide Support.....	導布器座.....	1
35	07401835	Lap Former Guide Spring.....	導布器彈簧片.....	1
36	07402636	Knife Support.....	上切刀支架.....	1
37	★ 07402637	Upper Knife.....	上刀片.....	1
38	07402638	Knife Holder.....	上刀片固定座.....	1
39	07402639	Screw (3/32-56X8).....	螺絲.....	2

★ 請參照附件1【針距規格表】

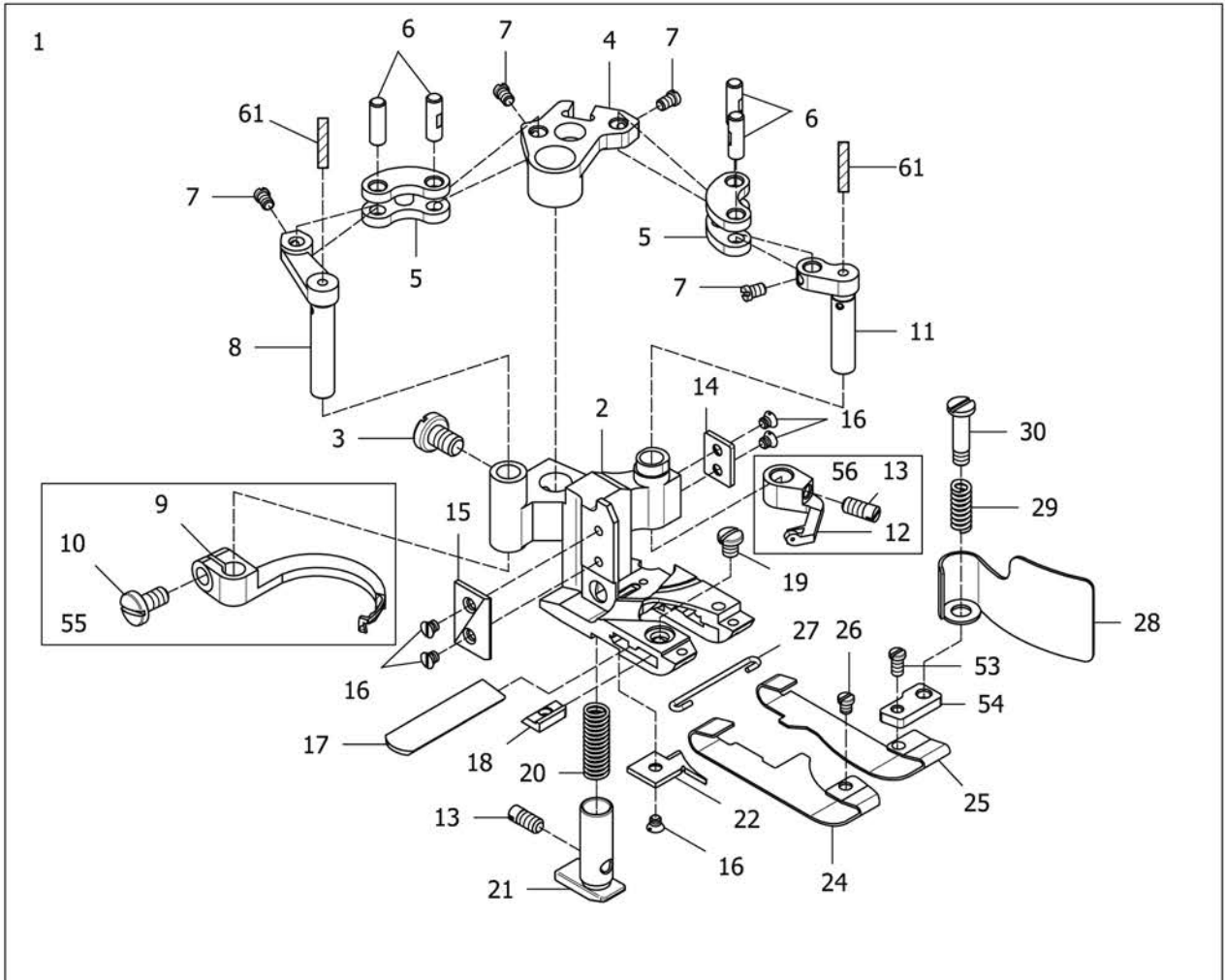
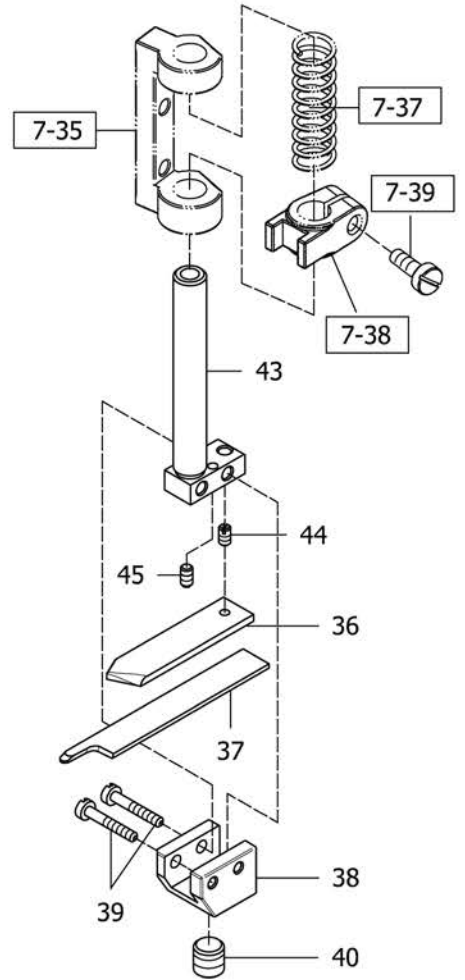
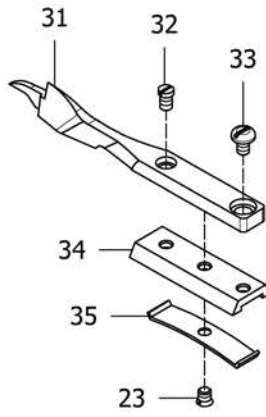
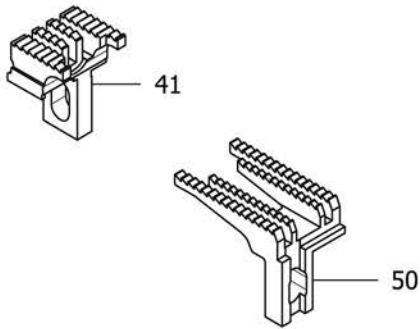
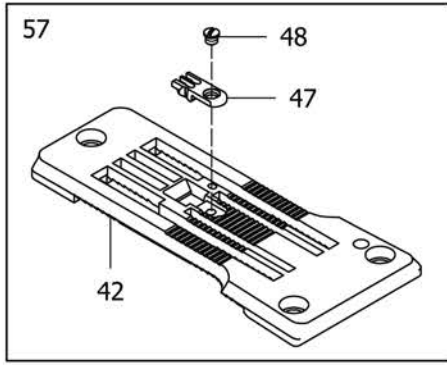

SELECT DEVICE(02RH)選擇配備(02RH) -弧狀車縫包縫過骨 **27**

Ref.	Parts			Amt.
<u>No.</u>	<u>No.</u>	<u>Description</u>	<u>品 名</u>	<u>Req.</u>
40	07400747	Screw (1/4-40X6).....	螺絲.....	1
41	★ 07401008	Main Feed Dog (For Single Cutter Only).....	後送齒(限用單切).....	1
42	★	Stitch Plate (For Single Cutter Only).....	針板(限用單切).....	1
43	07400740	Knife Holder Shank.....	上切刀固定座柄.....	1
44	07400743	Screw (3/32-56X1.2).....	螺絲.....	1
45	07400741	Screw (3/32-56X3.8).....	螺絲.....	1
47	★	Stitch Plate Tongue.....	針板舌.....	1
48	07400547	Screw (3/32-56X2).....	螺絲.....	1
50	★ 07401007	Differential Feed Dog.....	前送齒.....	1
53	07400650	Screw (3/32-56X4.8).....	螺絲.....	1
54	★ 07400649	Spacer.....	墊塊.....	1
55	07400646MF	Top Cover Thread Hook C.Set.....	上飾線勾針組(長).....	1
56	07400647MF	Top Cover Thread Carrier C.Set.....	上飾線勾針組(短).....	1
57	★	Stitch Plate C.Set (For Single Cutter Only).....	針板組(限用單切).....	1
61	★ 07400651	Green Wool.....	綠色毛線.....	2
	★ 請參照附件1【針距規格表】			

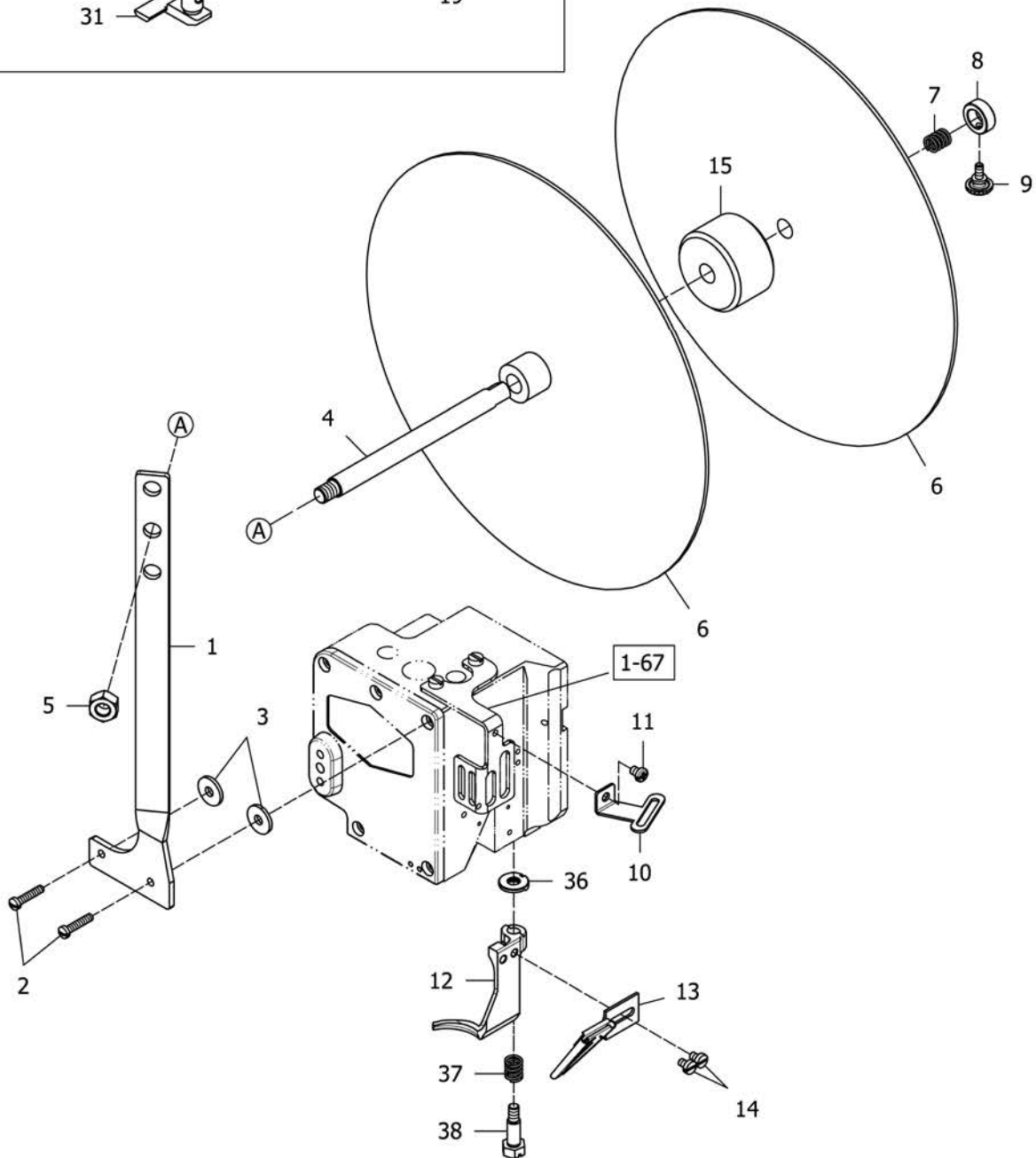
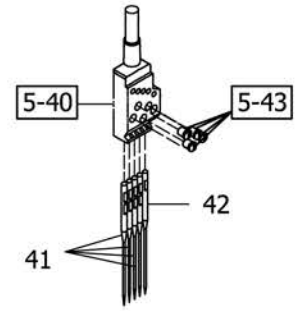
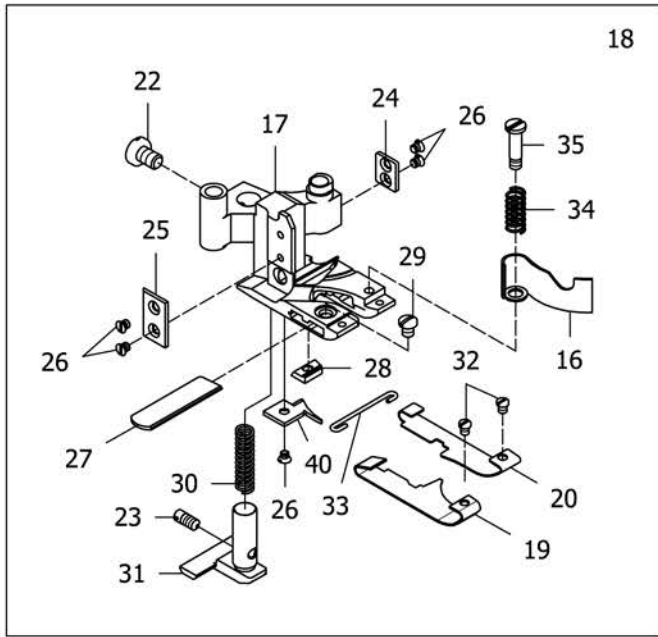

SELECT DEVICE(02-T2)

選擇配備(02-T2)-貼條

28

Ref.	Parts			Amt.
No.	No.	Description	品 名	Req.
1	07402201	Tape Reel Support.....	貼條架.....	1
2	07402202	Screw(9/64-40X17).....	螺絲.....	2
3	07402203	Rubber Cushion.....	橡膠墊片.....	2
4	07402204	Tape Reel Shaft.....	貼條主軸.....	1
5	07402205	Nut.....	螺帽.....	1
6	07402206	Tape Reel.....	貼條盤.....	2
7	07402207	Tape Reel Spring.....	彈簧.....	1
8	07402208	Collar(10X16X6mm).....	軸環.....	1
9	07402209	Screw(9/64-40X7.9).....	螺絲.....	1
10	07402210	Tape Guide.....	織帶導引支架.....	1
11	07402211	Screw(M4-0.7X5).....	螺絲.....	1
12	07402212	Frame Chip Guard.....	導布蓋.....	1
13	07402213	Binder.....	包邊器(喇叭).....	1
14	07402214	Screw(9/64-40X5).....	螺絲.....	2
15	07402215	Cushion Block.....	墊塊.....	1
16	★ 07402216	Chip Guard.....	切角防護片.....	1
17	★	Double Side Cut Presser Foot (02-T2).....	雙切貼條押腳.....	1
18	★	Presser Foot C. Set	押具組.....	1
19	★ 07402819	Presser Foot Spring Plate (Left).....	押具押板(左).....	1
20	★ 07402820	Presser Foot Spring Plate (Right).....	押具押板(右).....	1
22	07400615	Screw (11/64-40X6.3).....	螺絲.....	1
23	07400338	Screw (1/8-44X5).....	螺絲.....	1
24	★ 07400626	Presser Foot Attach Piece (Right).....	押腳連接片(右).....	1
25	★ 07400627	Presser Foot Attach Piece (Left).....	押腳連接片(左).....	1
26	07400628	Screw(3/32-56X1.5).....	螺絲.....	5
27	★ 07400629	Lower Knife.....	下切刀片.....	1
28	★ 07400630	Lower Knife Clamp.....	下切刀夾板.....	1
29	07400631	Screw (1/8-44X3.5).....	螺絲.....	1
30	★ 07400632	Yielding Section Spring.....	押具輔助座彈簧.....	1
31	★ 07401821	Yielding Section.....	押具輔助座.....	1
32	07400637	Screw (3/32-56X2.6).....	螺絲.....	2
33	★ 07400638	Spring Plate Holder.....	彈簧片固定座.....	1
34	★ 07400640	Chip Guard Spring.....	切角防護片彈簧.....	1
35	07400641	Screw (1/8-44X3.4).....	螺絲.....	1
36	07400182	Frame Chip Guard Washer.....	導布蓋固定墊片.....	1
37	07400183	Frame Chip Guard Spring.....	導布蓋彈簧.....	1
38	07400184	Screw (M5-0.8X8.5).....	螺絲.....	1
40	★ 07401822	Presser Foot Tongue.....	導布板.....	1
41	★	Needle.....	機針.....	4
42	★	Retainer.....	假針.....	1

★ 請參照附件1【針距規格表】

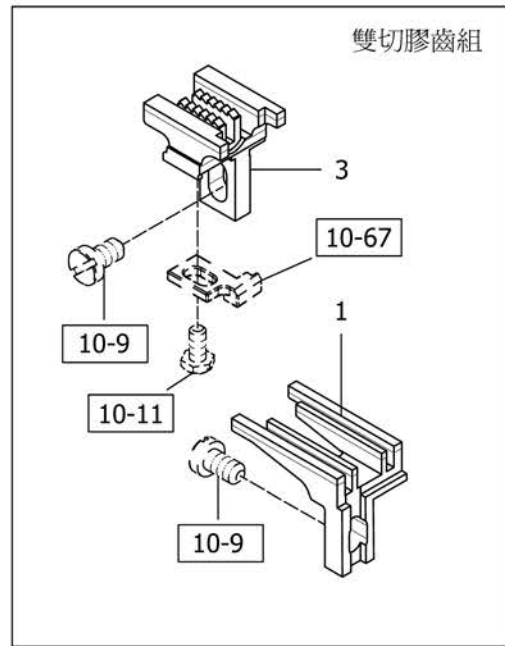
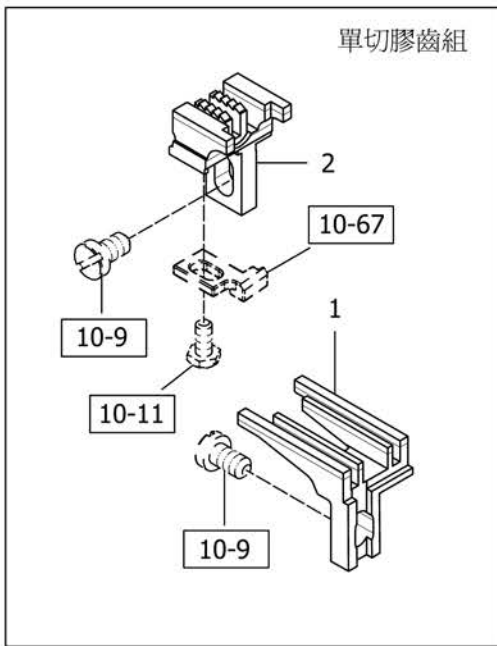

特殊勾齒使用時機

1. 為避免金屬勾齒造成布料上之齒痕而選用。
2. 為避免金屬勾齒造成薄料布料損傷、破洞之狀況而選用。

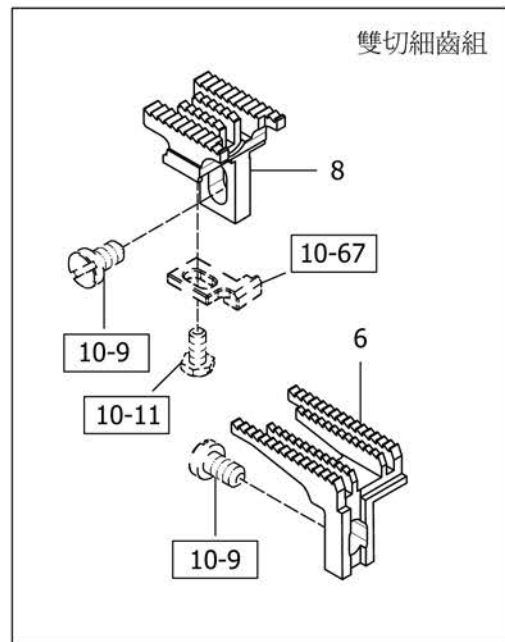
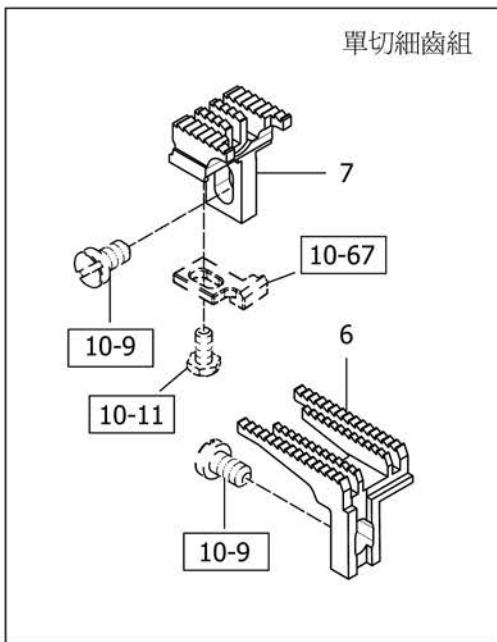

SELECT DEVICE(FEED DOG)

特殊勾齒(膠齒、細齒)

29

Ref.	Parts			Amt.
<u>No.</u>	<u>No.</u>	<u>Description</u>	<u>品 名</u>	<u>Req.</u>
1	07402901	Differential Feed Dog With Rubber (PU).....	優力膠前勾齒.....	2
2	07402902	Main Feed Dog With Rubber (PU) For Single Cutter.....	單切優力膠後勾齒.....	1
3	07402903	Main Feed Dog With Rubber (PU) For Double Cutter....	雙切優力膠後勾齒.....	1
6	07402906	Differential Feed Dog(Coarse Mesh).....	前勾齒(細齒).....	2
7	07402907	Main Feed Dog(Coarse Mesh) For Single Cutter.....	單切後勾齒(細齒).....	1
8	07402908	Main Feed Dog(Coarse Mesh) For Double Cutter.....	雙切後勾齒(細齒).....	1

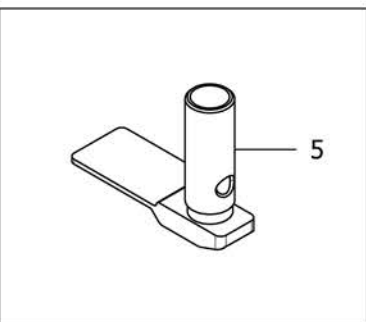
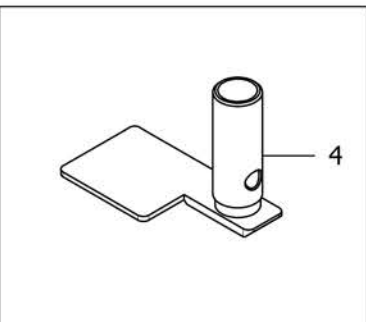
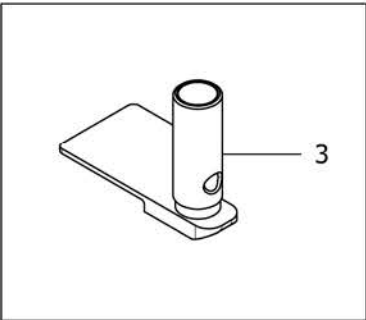
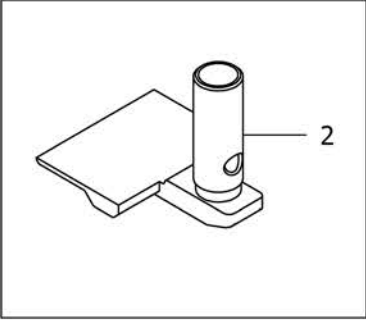
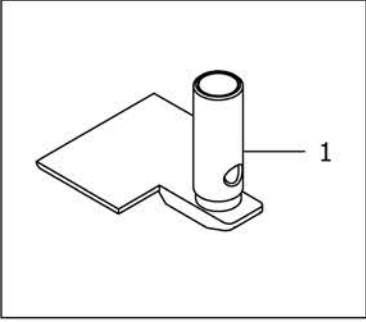

SELECT DEVICE(EK PRESSER FOOT)選擇配備(EK)-自動切線押腳 **31**

Ref.	Parts			Amt.
<u>No.</u>	<u>No.</u>	<u>Description</u>	<u>品 名</u>	<u>Req.</u>
1	★ 07403101	Yielding Section (One Side Cut).....	押具輔助座(單切用).....	1
2	★ 07403102	Yielding Section(Double Side Cut).....	押具輔助座(雙切用).....	1
3	★ 07403103	Yielding Section (470.480-01DS).....	押具輔助座(限用470.480-01DS).....	1
4	★ 07403104	Yielding Section (02-4L20).....	押具輔助座(限用02-4LXX).....	1
5	★ 07403105	Yielding Section (02R).....	押具輔助座(限用02R).....	1
	★ 請參照附件1【針距規格表】			

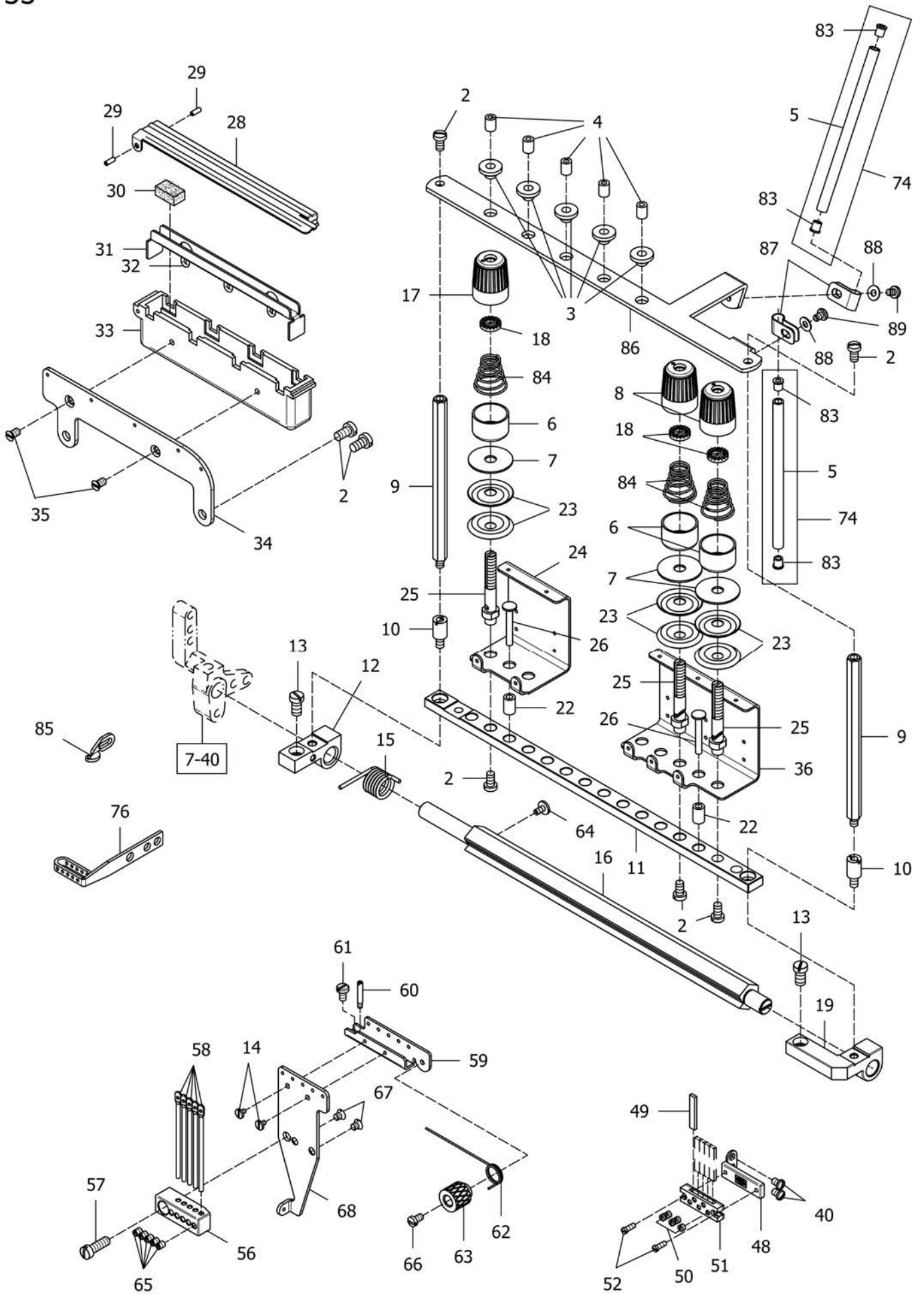

SELECT DEVICE(MISCELLANEOUS THREAD EYELETS-5NEEDLE) 選擇配備(過線機構-五針七線) 33

Ref.	Parts			Amt.
<u>No.</u>	<u>No.</u>	<u>Description</u>	<u>品 名</u>	<u>Req.</u>
2	07400302	Screw (11/64-40X7.8).....	螺絲.....	11
3	07400303	Thread Eyelet Bushing.....	過線孔套圈.....	5
4	07400304	Thread Eyelet.....	過線孔.....	5
5	07870321	Thread Pipe (Long).....	過線管(長).....	2
6	07870306	Spring Retainer.....	彈簧固定座.....	7
7	07870307	Felt.....	氈墊.....	7
8	07870343	Spring Cap.....	彈簧調整鈕.....	2
9	07400309	Thread Guide Plate Support.....	線架板支撐棒.....	2
10	07400397	Screw (11/64-40X7).....	螺絲.....	2
11	07403311	Thread Tension Support.....	上線張力固定座.....	1
12	07400399	Thread Tension Support Bracket.....	上線張力固定座支架.....	1
13	07400313	Screw (7/32-32X10).....	螺絲.....	2
14	07400314	Screw (3/32-56X3.1).....	螺絲.....	2
15	074003100	Tension Release Shaft Spring.....	張力釋放軸彈簧.....	1
16	07403316	Tension Release Shaft.....	張力釋放軸.....	1
17	07870301	Spring Cap.....	彈簧調整鈕.....	5
18	07870302A	Tension Spring Disc Support.....	張力彈簧調整圓盤.....	7
19	07403319	Thread Tension Support Bracket.....	上線張力固定座支架.....	1
22	07400322	Tension Release Pin Bushing.....	張力釋放插銷套管.....	8
23	07400323	Thread Tension Disc.....	張力調整盤.....	14
24	07400324	Thread Tension Disc Eyelet.....	張力調整過線架.....	2
25	07400325A	Tension Post.....	張力彈簧支柱.....	7
26	074003102	Tension Release Pin.....	張力釋放插銷.....	8
28	07400328	Oil Cup Lip.....	矽油儲存槽蓋.....	1
29	07400329	Hinge Pin.....	鉸鏈插銷.....	2
30	07400330	SP Felt.....	SP吸油氈.....	4
31	07400331	SP Felt Stay.....	SP吸油氈支柱.....	1
32	07400332	Oil Wick.....	油芯.....	1
33	07400333	SP Container.....	矽油儲存槽.....	1
34	07403334	SP Container Support.....	矽油儲存槽固定座.....	1
35	07400335	Screw (9/64-40X4.6).....	螺絲.....	2
36	07403336	Thread Tension Disc Eyelet.....	張力調整過線架.....	1
48	07403348	Needle Thread Strike-off Pin Holder Bracket...	打線片固定架.....	1

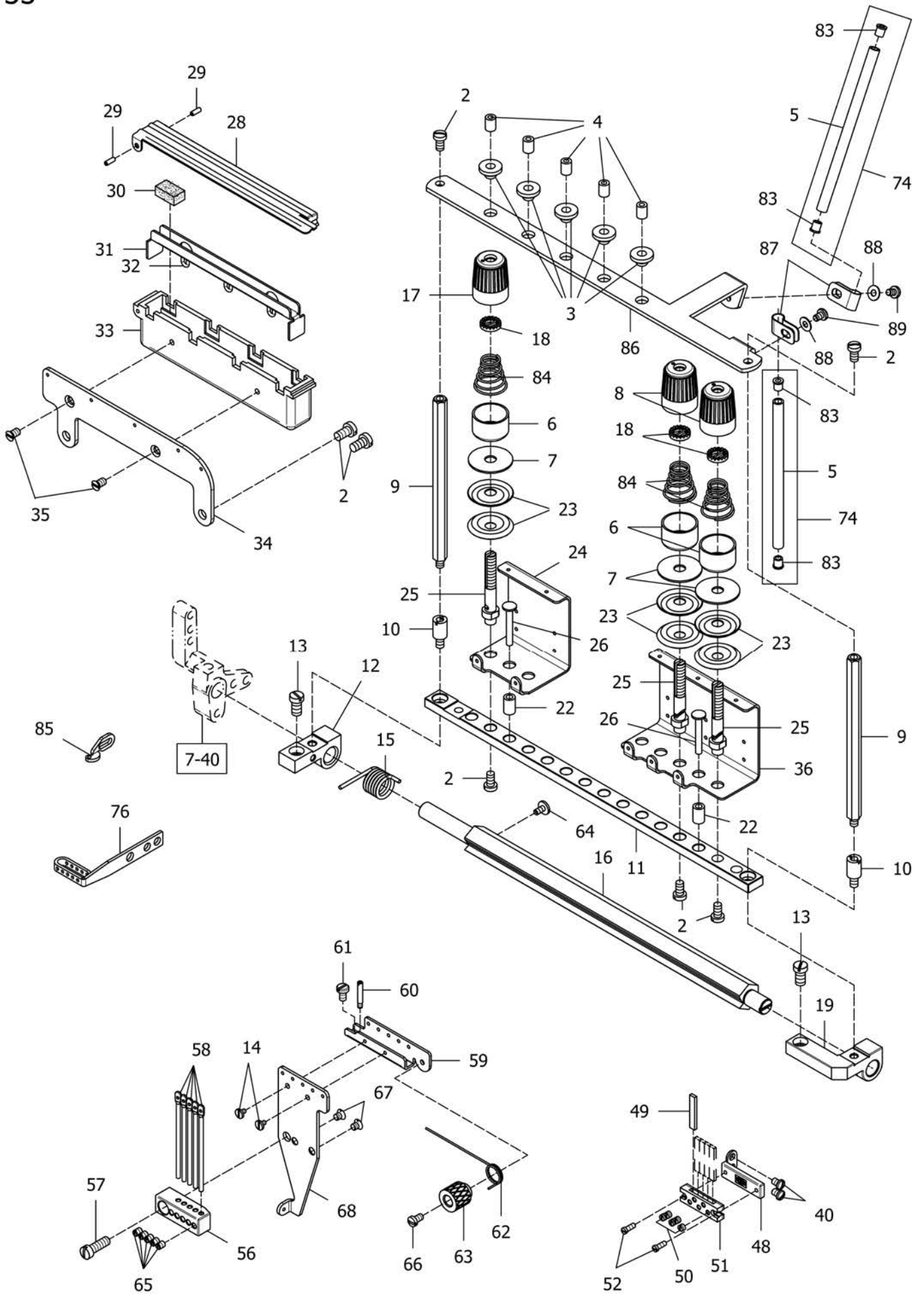

SELECT DEVICE(MISCELLANEOUS THREAD EYELETS-5NEEDLE) 選擇配備(過線機構-五針七線) 33

Ref.	Parts			Amt.
<u>No.</u>	<u>No.</u>	<u>Description</u>	<u>品 名</u>	<u>Req.</u>
49	07400349	Needle Thread Strike-off Pin.....	打線片.....	5
50	07400350	Screw (1/8-44X2).....	螺絲.....	5
51	07403351	Needle Thread Strike-off Pin Holder.....	打線片固定座.....	1
52	07400352	Screw (3/32-56X6.2).....	螺絲.....	2
56	07403356	Needle Thread Eyelet Holder.....	針線過線棒座.....	1
57	07400357	Screw (11/64-40X13).....	螺絲.....	1
58	07400358	Needle Thread Eyelet.....	針線過線棒.....	5
59	07403359	Stitch Unlocker Mounting Bracket.....	過線架.....	1
60	07400360	Screw (M2.3-0.4X3).....	螺絲.....	1
61	07400361	Screw (1/8-44X5.9).....	螺絲.....	1
62	07403362	Stitch Unlocking Spring.....	過線彈簧.....	1
63	07400363	Stitch Unlocking Spring Holder.....	過線彈簧調節鈕.....	1
64	07400364	Screw (1/8-44X6.4).....	螺絲.....	1
65	07400365	Screw (1/8-44X3.4).....	螺絲.....	5
66	07400366	Screw (1/8-44X5.6).....	螺絲.....	3
67	07400367	Screw (1/8-44X2.7).....	螺絲.....	2
68	07403368	Stitch Unlocking Holder.....	過線座.....	1
74	07400374	Thread Pipe C.Set (Long).....	過線管組(長).....	2
76	07403376	Needle Thread Take-up.....	導線架.....	1
83	07870363	Thread Eyelet.....	過線陶瓷(深灰).....	4
84	074003105	Needle Thread Tension Spring.....	針線張力彈簧.....	7
85	07400354	Head Cover Thread Eyelet.....	車台前蓋過線孔.....	1
86	07403386	Thread Guide Plate.....	線架板.....	1
87	074003111	Tube Clip.....	管夾.....	2
88	07400139	Washer.....	墊片.....	2
89	07400227	Screw (9/64-40X5).....	螺絲.....	2

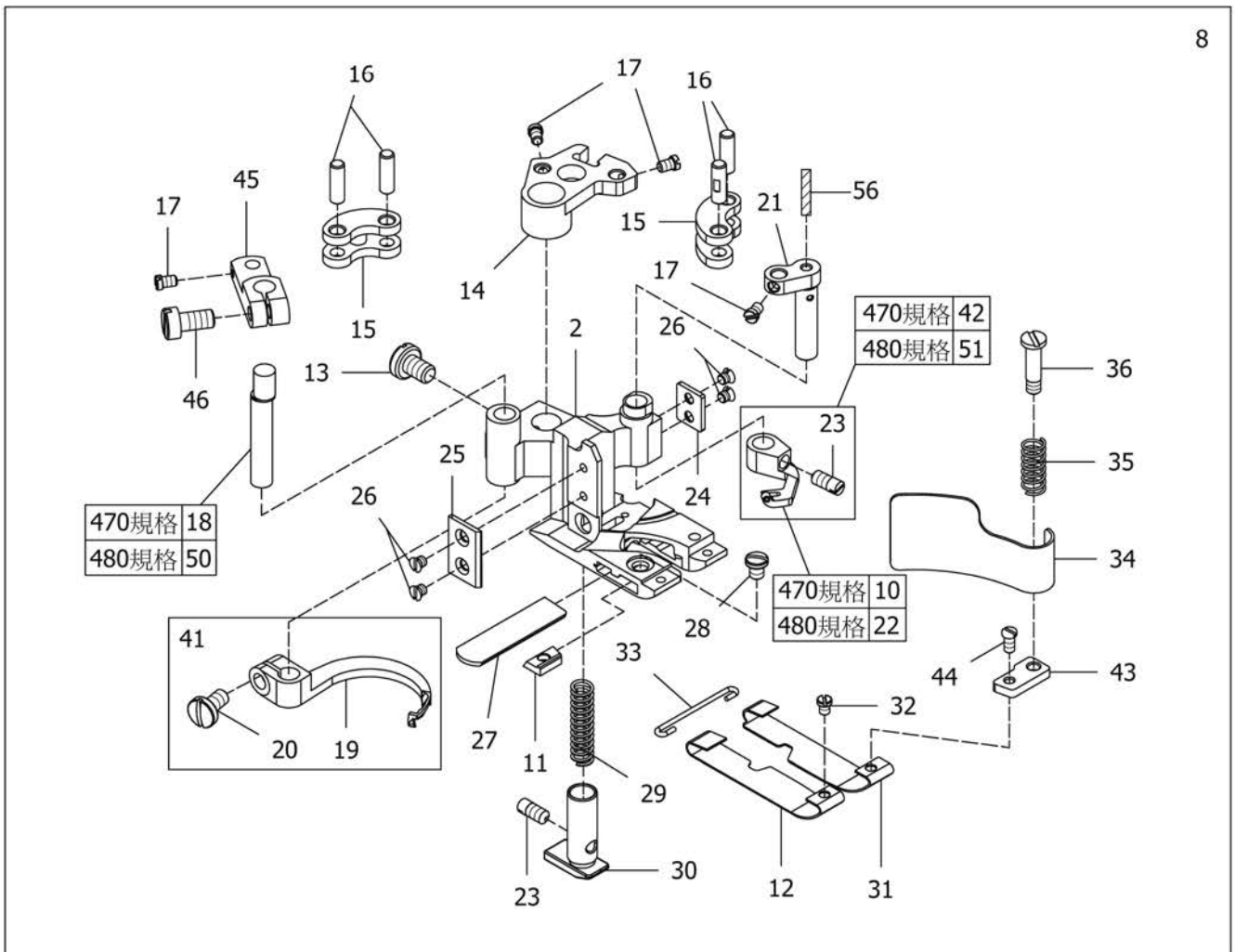
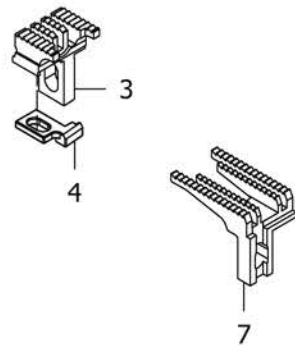
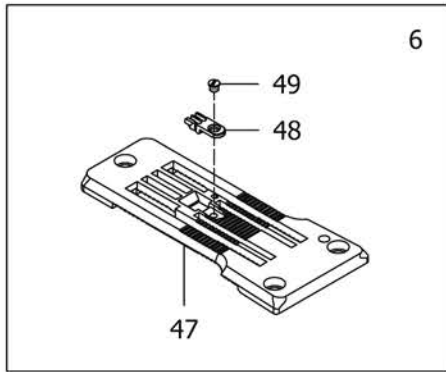
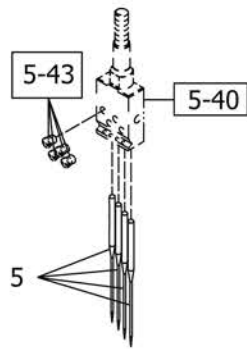

SELECT DEVICE(01-DS)-470.480

選擇配備(01-DS)-潛水衣 **34**

Ref.	Parts			Amt.
No.	No.	Description	品名	Req.
2	★	Presser Foot (01)-470.480.....	專用押腳(01)-規格470.480...	1
3	★ 07403403	Main Feed Dog	單切後送齒.....	1
4	★ 07403404	Needle Guard(Rear).....	針檔(後).....	1
5	★	Needle.....	機針.....	4
6	★	Stitch Plate C.Set.....	針板組.....	1
7	★ 07402407	Differential Feed Dog.....	前送齒.....	1
8	★	Presser Foot C. Set	專用押具組.....	1
10	★ 07403410MF	Top Cover Thread Carrier.....	上飾線勾針(短).....	1
11	★ 07400630	Lower Knife Clamp.....	下切刀夾板.....	1
12	★ 07403412	Presser Foot Spring Plate (Left).....	押具押板(左).....	1
13	07400615	Screw (11/64-40X6.3).....	螺絲.....	1
14	★ 07400616	Carrier/Hook Driving Segment.....	上勾針驅動扇形片.....	1
15	★ 07400617	Carrier/Hook Driving Lever Link.....	上勾針驅動連桿.....	2
16	★ 07400618	Link Pin.....	連桿插銷.....	4
17	07400619	Screw (3/32-56X3.3).....	螺絲.....	4
18	★ 07403418	Thread Hook Driving Lever (For 470 Only)....	勾針驅動槓桿(限用470)....	1
19	★ 07400621MF	Top Cover Thread Hook.....	上飾線勾針(長).....	1
20	07400622	Screw (9/64-40X6.8).....	螺絲.....	1
21	★ 07400623	Top Cover Thread Carrier Driving Lever.....	上飾線托架驅動槓桿.....	1
22	★ 07403422MF	Top Cover Thread Carrier (For 480 Only).....	上飾線勾針(短)(限用480)·	1
23	07400338	Screw (1/8-44X5).....	螺絲.....	2
24	★ 07400626	Presser Foot Attach Piece (Right).....	押腳連接片(右).....	1
25	★ 07400627	Presser Foot Attach Piece (Left).....	押腳連接片(左).....	1
26	07400628	Screw(3/32-56X1.5).....	螺絲.....	4
27	★ 07400629	Lower Knife.....	下切刀片.....	1
28	07400631	Screw (1/8-44X3.5).....	螺絲.....	1
29	07400632	Yielding Section Spring.....	押具輔助座彈簧.....	1
30	★ 07402116	Yielding Section.....	押具輔助座.....	1
31	★ 07403431	Presser Foot Spring Plate (Right).....	押具押板(右).....	1
32	07400637	Screw (3/32-56X2.6).....	螺絲.....	1
33	★ 07400638	Spring Plate Holder.....	彈簧片固定座.....	1
34	★ 07400639	Chip Guard.....	切角防護片.....	1
35	★ 07400640	Chip Guard Spring.....	切角防護片彈簧.....	1
36	07400641	Screw (1/8-44X3.4).....	螺絲.....	1
41	07400646MF	Top Cover Thread Hook C.Set.....	上飾線勾針組(長).....	1
42	07403442MF	Top Cover Thread Carrier C.Set (For 470 Only).....	上飾線勾針組(短)(限用470)...	1
43	★ 07400649	Spacer.....	墊塊.....	1

★ 請參照附件1【針距規格表】

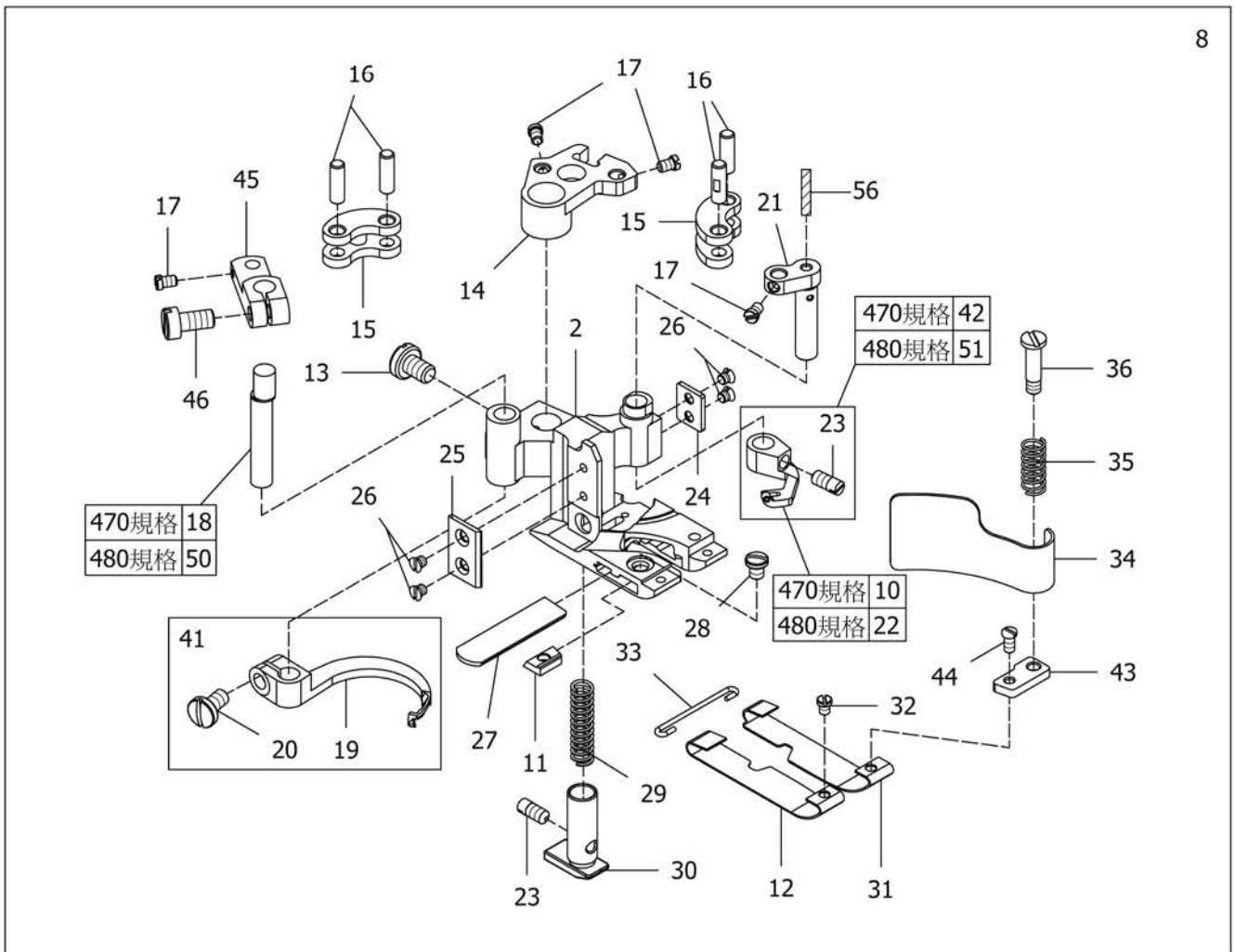
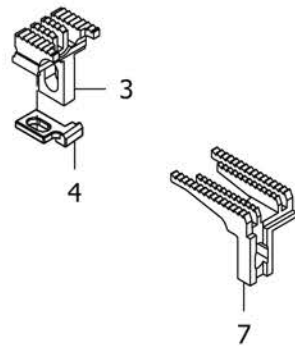
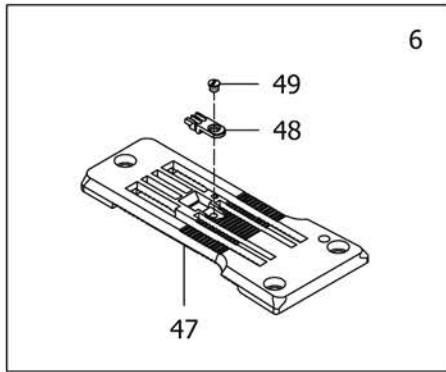
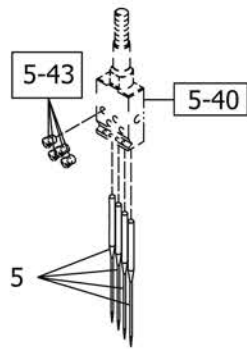

SELECT DEVICE(01-DS)-470.480選擇配備(01-DS)-潛水衣 **34**

Ref.	Parts			Amt.
<u>No.</u>	<u>No.</u>	<u>Description</u>	<u>品 名</u>	<u>Req.</u>
44	07400650	Screw (3/32-56X4.8).....	螺絲.....	1
45	★ 07403445	Driving Lever.....	驅動連桿.....	1
46	07400168	Screw (M4-0.7X8).....	螺絲(一字頭).....	1
47	★	Stitch Plate.....	單切針板.....	1
48	★	Stitch Plate Tongue.....	針板舌.....	1
49	07400547	Screw (3/32-56X2).....	螺絲.....	1
50	★ 07403450	Thread Hook Driving Lever (For 480 Only).....	勾針驅動槓桿(限用480).....	1
51	07403451MF	Top Cover Thread Carrier C.Set (For 480 Only).....	上飾線勾針組(短)(限用480).....	1
56	★ 07400651	Green Wool.....	綠色毛線.....	1
	★ 請參照附件1【針距規格表】			

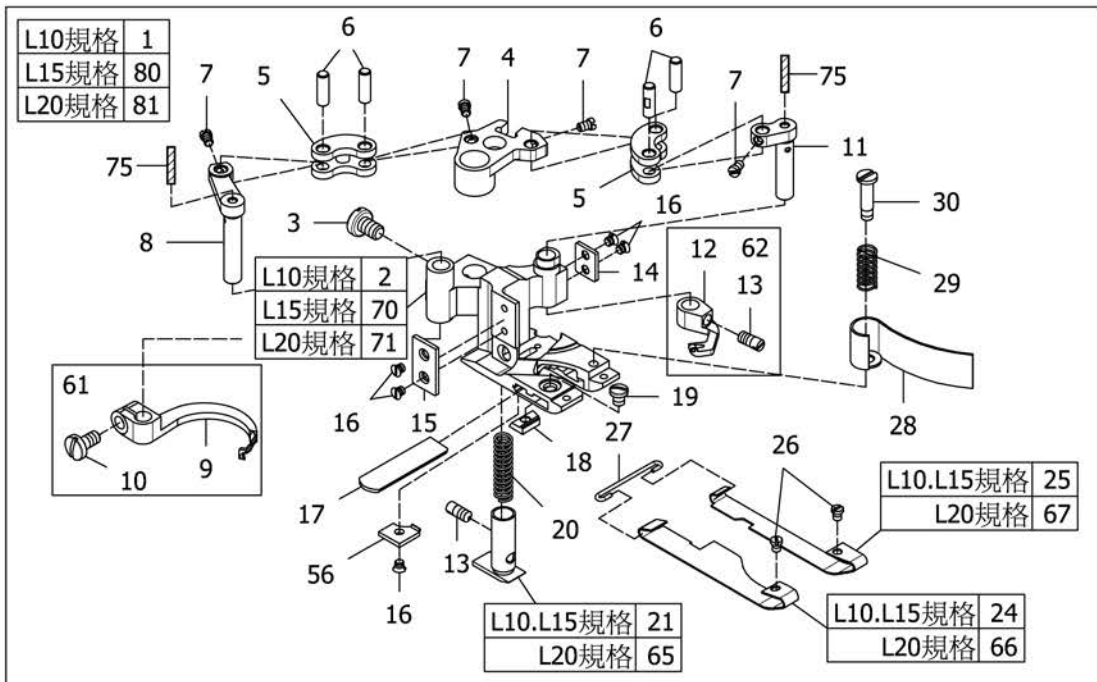
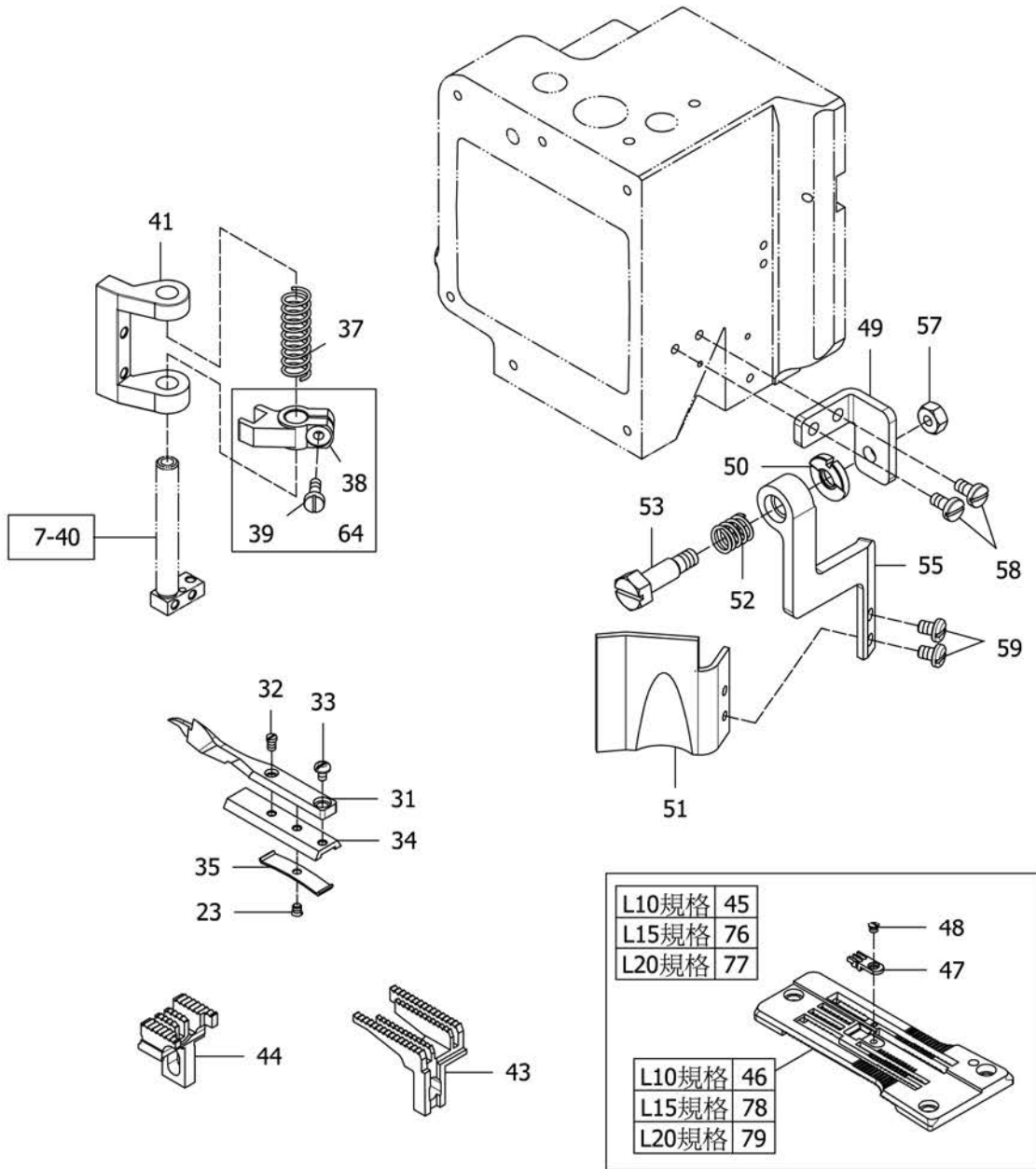

SELECT DEVICE(02-4LXX)

Ref.	Parts			Amt.
No.	No.	Description	品名	Req.
1	★	Double Side Cut Presser Foot C.Set (L10).....	雙切押具組(L10).....	1
2	★	Double Side Cut Presser Foot (L10).....	雙切段差厚料押腳(L10).....	1
3	07400615	Screw (11/64-40X6.3).....	螺絲.....	1
4	★ 07400616	Carrier/Hook Driving Segment.....	上勾針驅動扇形片.....	1
5	★ 07400617	Carrier/Hook Driving Lever Link.....	上勾針驅動連桿.....	2
6	★ 07400618	Link Pin.....	連桿插銷.....	4
7	07400619	Screw (3/32-56X3.3).....	螺絲.....	4
8	★ 07400620	Thread Hook Driving Lever.....	勾針驅動槓桿.....	1
9	★ 07400621MF	Top Cover Thread Hook.....	上飾線勾針(長).....	1
10	07400622	Screw (9/64-40X6.8).....	螺絲.....	1
11	★ 07400623	Top Cover Thread Carrier Driving Lever.....	上飾線托架驅動槓桿.....	1
12	★ 07403512MF	Top Cover Thread Carrier.....	上飾線勾針(短).....	1
13	07400338	Screw (1/8-44X5).....	螺絲.....	2
14	★ 07400626	Presser Foot Attach Piece (Right).....	押腳連接片(右).....	1
15	★ 07403515	Presser Foot Attach Piece (Left).....	押腳連接片(左).....	1
16	07400628	Screw(3/32-56X1.5).....	螺絲.....	5
17	★ 07400629	Lower Knife.....	下切刀片.....	1
18	★ 07400630	Lower Knife Clamp.....	下切刀夾板.....	1
19	07400631	Screw (1/8-44X3.5).....	螺絲.....	1
20	★ 07400632	Yielding Section Spring.....	押具輔助座彈簧.....	1
21	★ 07403521	Yielding Section (L10.L15).....	押具輔助座(L10.L15).....	1
23	07401823	Screw (3/32-56X2).....	螺絲.....	1
24	★ 07403524	Presser Foot Spring Plate (Left)(L10.L15).....	押具押板(左)(L10.L15).....	1
25	★ 07403525	Presser Foot Spring Plate (Right)(L10.L15).....	押具押板(右)(L10.L15).....	1
26	07400637	Screw (3/32-56X2.6).....	螺絲.....	2
27	★ 07400638	Spring Plate Holder.....	彈簧片固定座.....	1
28	★ 07403528	Chip Guard.....	切角防護片.....	1
29	★ 07400640	Chip Guard Spring.....	切角防護片彈簧.....	1
30	07400641	Screw (1/8-44X3.4).....	螺絲.....	1
31	★ 07403531	Lap Former Guide.....	導布器.....	1
32	07401832	Screw (3/32-56X3.5).....	螺絲.....	1
33	07401833	Screw (3/32-56X3.9).....	螺絲.....	1
34	07403534	Lap Former Guide Support.....	導布器座.....	1
35	07401835	Lap Former Guide Spring.....	導布器彈簧片.....	1
37	07400772	Knife Holder Spring.....	上切刀固定座彈簧.....	1
38	07403538	Knife Holder Guide Collar.....	刀台襯套.....	1
39	07400739	Screw (9/64-40X9).....	螺絲.....	1

★ 請參照附件1【針距規格表】

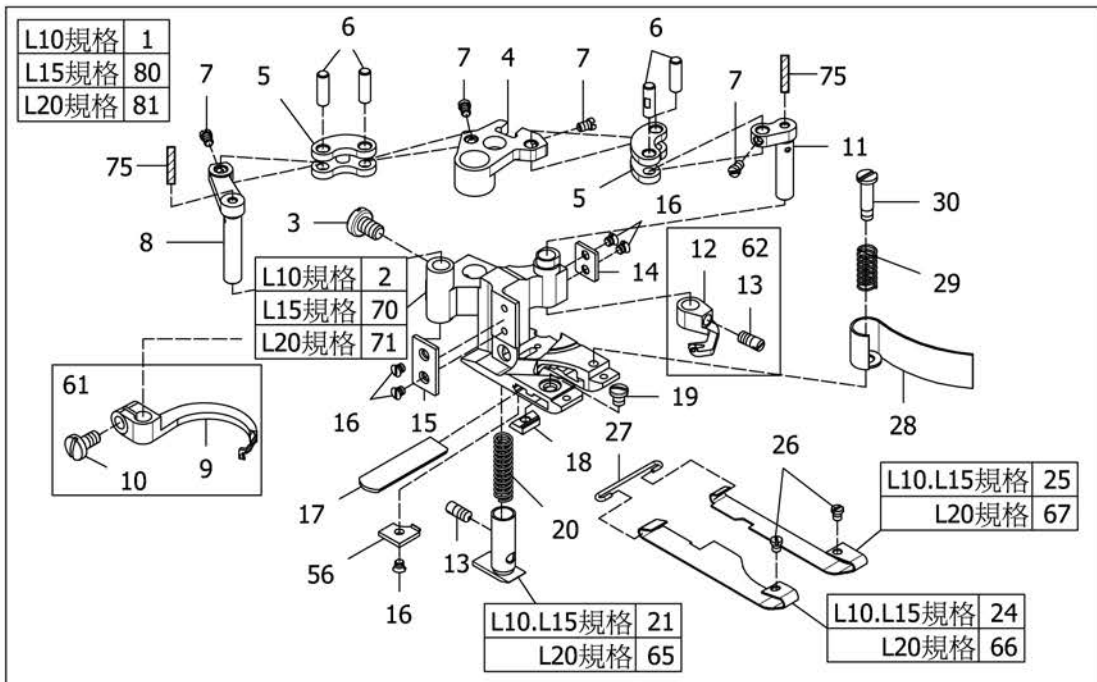
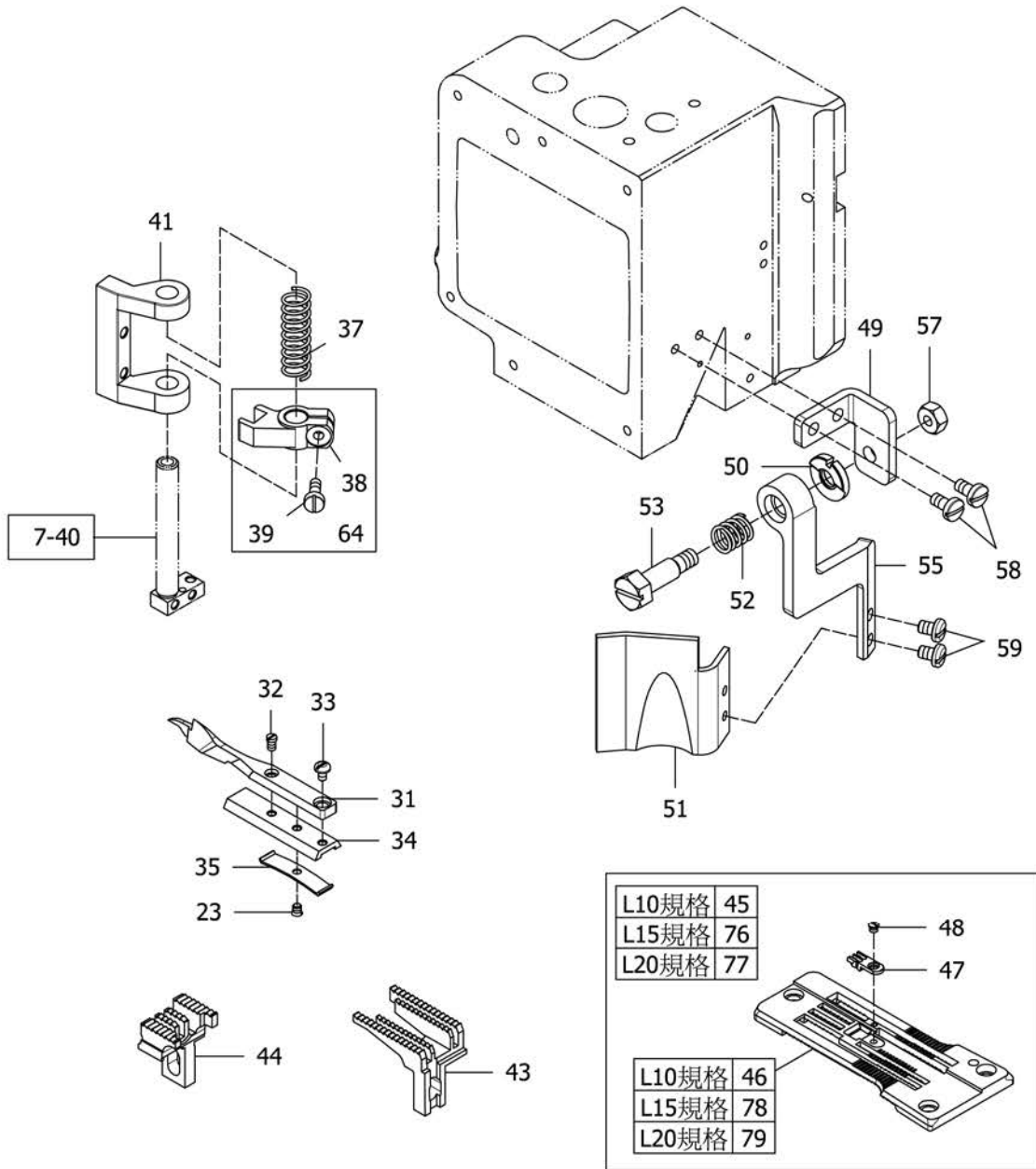

SELECT DEVICE(02-4LXX)

Ref.	Parts			Amt.
No.	No.	Description	品名	Req.
41	07403541	Knife Holder Shank Support.....	上切刀固定座支架.....	1
43	★	Differential Feed Dog.....	前送齒.....	1
44	★	Main Feed Dog.....	後送齒.....	1
45	★	Stitch Plate C.Set (L10).....	針板組(L10).....	1
46	★	Stitch Plate (L10).....	針板(L10).....	1
47	★	Stitch Plate Tongue.....	針板舌.....	1
48	07400547	Screw (3/32-56X2).....	螺絲.....	1
49	07403549	Frame Chip Guard Bracket.....	導布蓋支架.....	1
50	07400182	Frame Chip Guard Washer.....	導布蓋固定墊片.....	1
51	07403551	Frame Chip Guard.....	導布蓋.....	1
52	07400183	Frame Chip Guard Spring.....	導布蓋彈簧.....	1
53	07400184	Screw (M5-0.8X8.5).....	螺絲.....	1
55	07403555	Frame Chip Guard Support.....	導布蓋固定座.....	1
56	★ 07403556	Presser Foot Tongue.....	導布板.....	1
57	07871028	Nut.....	螺帽.....	1
58	07400150	Screw (9/64-40X7).....	螺絲.....	2
59	07400227	Screw (9/64-40X5).....	螺絲.....	2
61	07400646MF	Top Cover Thread Hook C.Set.....	上飾線勾針組(長).....	1
62	07403562MF	Top Cover Thread Carrier C.Set.....	上飾線勾針組(短).....	1
64	07403564	Knife Holder Guide Collar C.Set.....	刀台襯套組.....	1
65	★ 07403565	Yielding Section(L20).....	押具輔助座(L20).....	1
66	★ 07403566	Presser Foot Spring Plate (Left)(L20).....	押具押板(左)(L20).....	1
67	★ 07403567	Presser Foot Spring Plate (Right)(L20).....	押具押板(右)(L20).....	1
70	★	Double Side Cut Presser Foot (L15).....	雙切段差厚料押腳(L15).....	1
71	★	Double Side Cut Presser Foot (L20).....	雙切段差厚料押腳(L20).....	1
75	★ 07400651	Green Wool.....	綠色毛線.....	2
76	★	Stitch Plate C.Set (L15).....	針板組(L15).....	1
77	★	Stitch Plate C.Set (L20).....	針板組(L20).....	1
78	★	Stitch Plate (L15).....	針板(L15).....	1
79	★	Stitch Plate (L20).....	針板(L20).....	1
80	★	Double Side Cut Presser Foot C.Set (L15).....	雙切押具組(L15).....	1
81	★	Double Side Cut Presser Foot C.Set (L20).....	雙切押具組(L20).....	1

★ 請參照附件1【針距規格表】

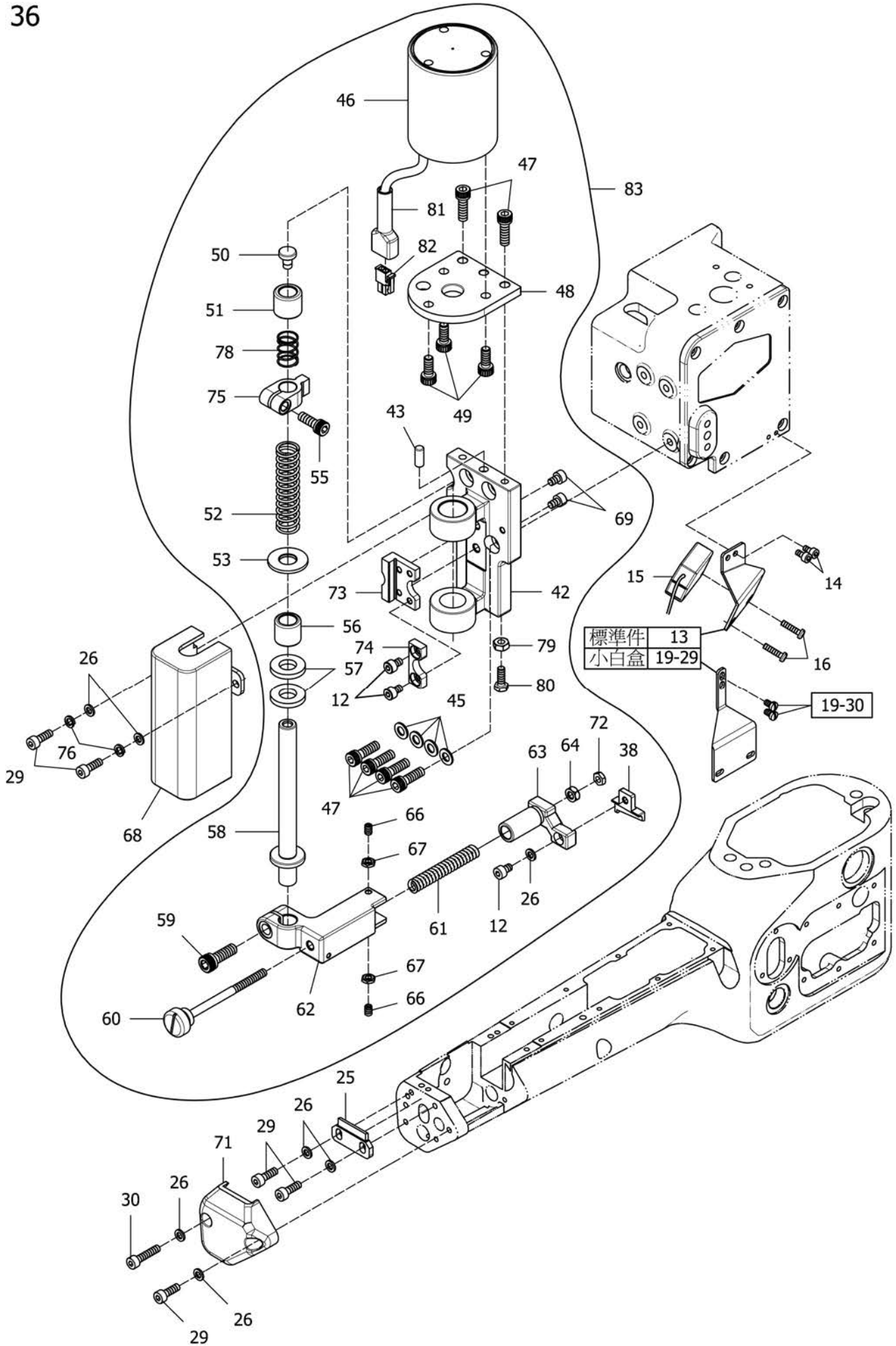

SELECT DEVICE(EK)**選擇配備(EK)-自動切線****36**

Ref.	Parts			Amt.
<u>No.</u>	<u>No.</u>	<u>Description</u>	<u>品 名</u>	<u>Req.</u>
12	07403012	Screw(M4-0.7X6).....	螺絲.....	3
13	07403013	Switches Holder.....	電眼架(側面).....	1
14	07403014	Screw(M3-0.5X6).....	螺絲.....	2
15	07403015	Photoelectric Switches.....	光電感應器.....	1
16	07872110	Screw(M3-0.5X12).....	螺絲.....	2
25	07403025	Lower Knife.....	下切刀.....	1
26	07870650	Washer.....	墊片.....	7
29	07403029	Screw (M4-0.7X12).....	螺絲.....	5
30	07403030	Screw (M4-0.7X18).....	螺絲.....	1
38	07403038	Upper Knife.....	上切刀.....	1
42	07403642	EK Holder.....	電磁式自動切線固定架.....	1
43	07403643	Pin.....	插銷.....	1
45	07401547	Washer.....	墊片.....	4
46	07403646	Solenoid.....	電磁鐵.....	1
47	07401534	Screw (M5-0.8X16)	螺絲.....	6
48	07403648	Solenoid Bracket.....	電磁鐵吊架.....	1
49	07401429	Screw (M5-0.8X10)	螺絲.....	3
50	07403650	Plug.....	橡膠塞.....	1
51	07403651	Bushing(Upper).....	套管(上).....	1
52	07403652	Spring.....	定位緩衝壓簧.....	1
53	07870921	Washer.....	墊片.....	1
55	07804106	Screw (M5-0.8X14)	螺絲.....	1
56	07403656	Bushing(Lower).....	套管(下).....	1
57	07403657	Rubber Cushion.....	避震膠墊.....	1
58	07403658	Upper Knife Driving Rod.....	上切刀驅動桿.....	1
59	07872212	Screw (M6-1X18)	螺絲.....	1
60	07403660	Knife Adjusting Post (11/64-40X25).....	上切刀調節支柱.....	1
61	07403661	Knife Holder Spring.....	上切刀固定座彈簧.....	1
62	07403662	Upper Knife Holder Sleeve.....	上切刀固定座套筒.....	1
63	07403663	Upper Knife Holder.....	上切刀固定座.....	1
64	07403664	Nut.....	螺帽.....	1
66	07870261	Screw (M4-0.7X6).....	螺絲.....	2
67	07403667	Nut.....	螺帽.....	2

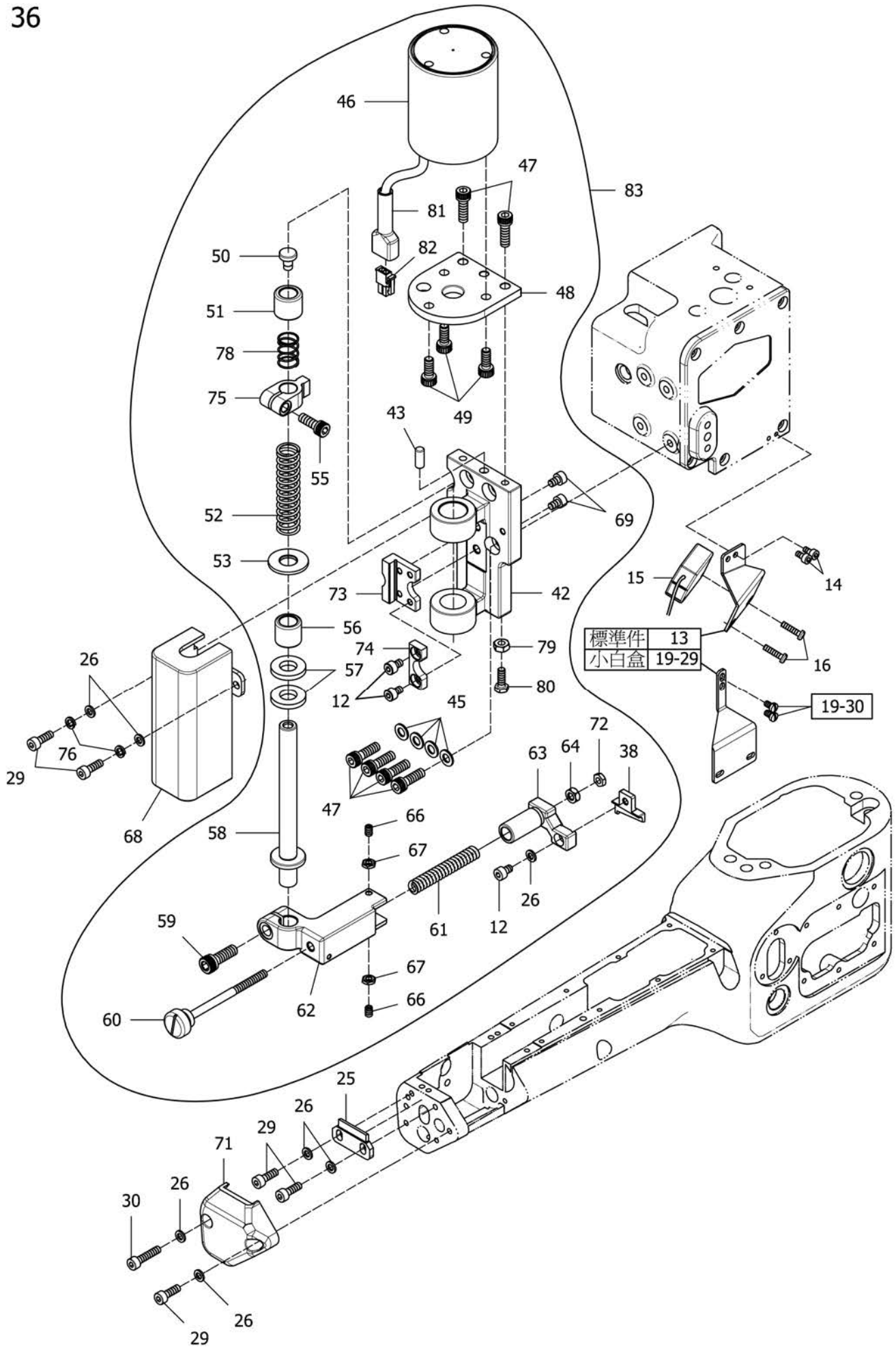

SELECT DEVICE(EK)

選擇配備(EK)-自動切線

36

Ref.	Parts			Amt.
<u>No.</u>	<u>No.</u>	<u>Description</u>	<u>品 名</u>	<u>Req.</u>
68	07403668	EK Cover.....	電磁式自切護罩.....	1
69	07870256	Screw (M4-0.7X8).....	螺絲.....	2
71	07403671	Lower Knife Cover.....	下切刀護罩.....	1
72	07400110	Nut.....	螺帽.....	1
73	07403673	Shank Support.....	固定座支架.....	1
74	07403674	Slide Block.....	定位滑塊.....	1
75	07403675	Upper Knife Driving Rod Connecting Bracket..	上切刀驅動桿連結架.....	1
76	07300249	Spring Washer.....	彈簧墊片.....	1
78	07403678	Spring.....	緩衝壓簧.....	1
79	07870244	Nut.....	螺帽.....	1
80	07403680	Screw (M4-0.7X12).....	螺絲.....	1
81	07871744	Wiper Terminal Rubber Cover.....	撥線端子護套.....	1
82	07871745	Joint.....	端子座.....	1
83	07403683	EK Upper Knife C.Set.....	自切上切刀組.....	1

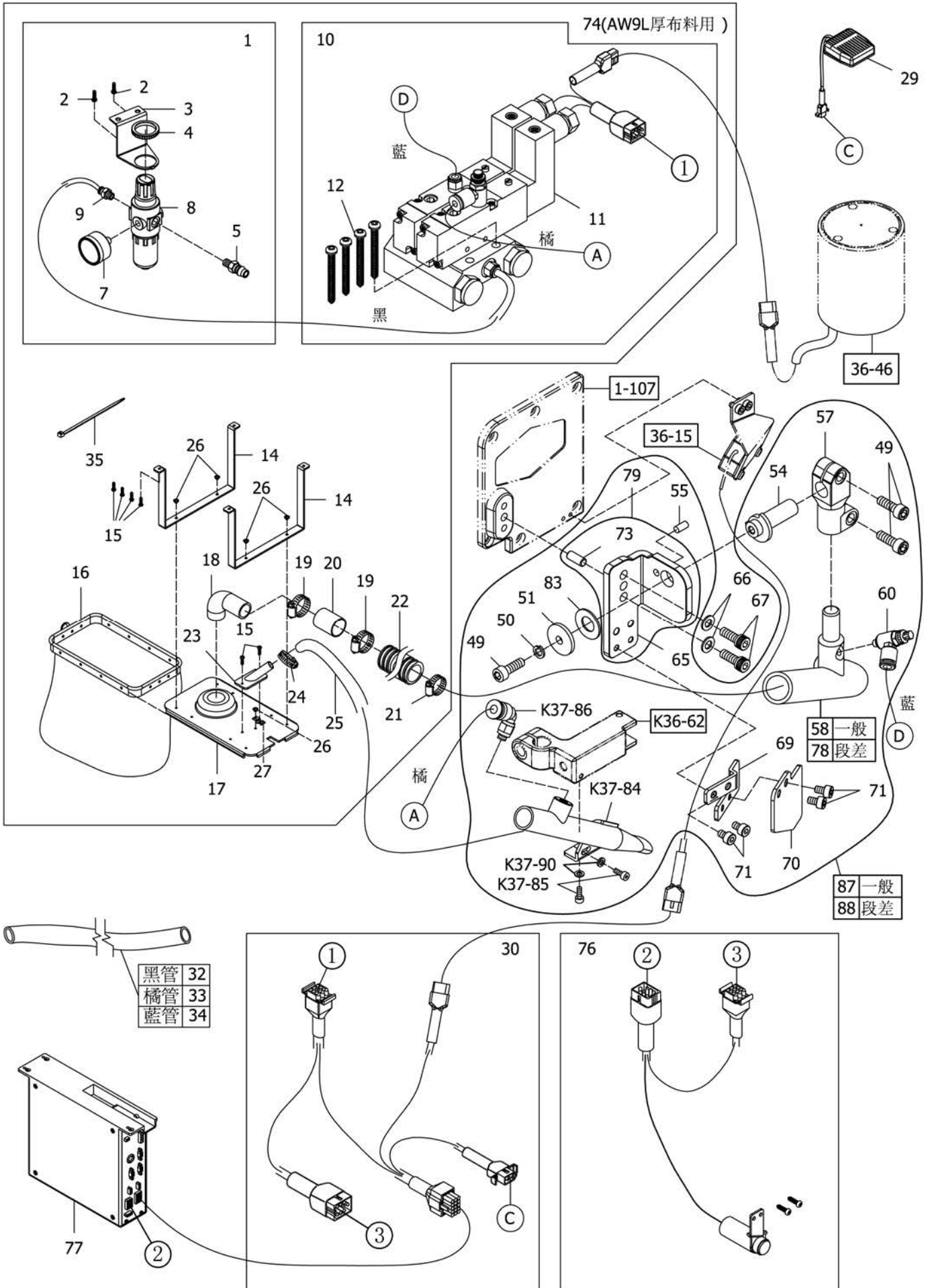

EK集塵裝置-AW9L、AW9S(選擇配備)

Ref. No.	Parts No.	Description	品名	Amt. Req.
1	07804716	Pneumatic Regulator C.Set.....	氣壓調節器組.....	1
2	07872402	Wood Screw.....	木螺絲.....	2
3	07872403	Bracket.....	托架.....	1
4	07872404	Screw Ring.....	螺環.....	1
5	07872405	Coupler.....	轉接頭.....	1
7	07872407	Gauge.....	氣磅表.....	1
8	07872408	Pneumatic Regulator.....	氣壓調節器.....	1
9	07872401	Coupler.....	轉接頭.....	1
10	07403710	Solenoid Valve C.Set.....	電磁閥組.....	1
11	07403711	Solenoid Valve.....	電磁閥.....	1
12	07403212	Wood Screw.....	木螺絲.....	4
14	07804732	Holder.....	固定座.....	2
15	07804705	Wood Screw.....	木螺絲.....	6
16	07804728	Bag.....	布屑袋.....	1
17	07403217	Cover.....	布屑蓋.....	1
18	07401545	Clear Pipe.....	吸屑管.....	1
19	07401529	Fixed Ring.....	套環.....	2
20	07401503A	Connect Tube.....	接管.....	1
21	07401517	Fixed Ring.....	套環.....	1
22	07401506A	Tube.....	風管(大).....	1
23	07403223	Clear Pipe.....	吸屑管.....	1
24	07403224	Fixed Ring.....	套環.....	1
25	07403225	Tube.....	風管(小).....	1
26	07804733	Screw (M4-0.7X3.5).....	螺絲.....	5
27	07804734	Spring Washer.....	彈片.....	1
29	07403229	Knee Switch.....	膝動開關.....	1
30	07403230	Relay Line.....	中繼線.....	1
32	07403232	Tube (Blue).....	氣管(黑)(6mmX28in).....	1
33	07403233	Tube (Orange).....	氣管(橘)(6mmX60in).....	2
34	07401549	Tube (Blue).....	氣管(藍)(6mmX60in).....	2
35	130101002	Ties.....	束線帶(CV-250).....	15
41	07401553	Connect Tube.....	接管.....	1
42	07401504	Fixed Ring.....	套環.....	1
43	07401554	Tube.....	風管(小).....	1

EK集塵裝置-AW9L、AW9S(選擇配備)

Ref.	Parts			Amt.
No.	No.	Description	品 名	Req.
49	07401534	Screw(M5-0.8X16).....	螺絲(內六角).....	3
50	07401548	Spring Washer.....	彈簧防振墊片.....	1
51	07401531	Washer.....	墊片.....	1
54	07401536	Connecting Rod Pin.....	連桿插銷.....	1
55	07401535	Pin.....	插銷.....	1
57	07401533	Connecting Rod.....	連桿.....	1
58	07401527A	Clear Pipe.....	吸屑管(大)(一般用).....	1
59	07401551	Clear Pipe.....	吸屑管(小).....	1
60	07401538A	Speed Connector.....	調速接頭(B式).....	1
61	07401552	Speed Connector.....	調速接頭(B式).....	1
65	07403765	Bracket.....	托架.....	1
66	07401547	Washer.....	墊片.....	2
67	07804106	Screw(M5-0.8X14).....	螺絲.....	2
69	07403769	Safety Plate Support.....	護目鏡固定座.....	1
70	07403770	Safety Plate.....	護目鏡片.....	1
71	07403012	Screw(M4-0.7X6).....	螺絲.....	4
73	07403643	Pin.....	插銷.....	1
74	07403731	Clear System.....	吸風組(大管-厚布料用).....	1
75	07403775	AK Clear System.....	吸風組(小管-薄布料用).....	1
76	07403776	Knife Switch C.Set.....	切刀開關組.....	1
77	07401242	Control Box.....	控制箱.....	1
78	07401560	Clear Pipe (For 02-4LXX).....	吸屑管(大)(段差用).....	1
79	07403779	Bracket C.Set.....	托架組.....	1
83	07401562	Conical Spring Washer.....	錐形彈簧墊圈.....	1
84	07403784	Clear Pipe.....	吸屑管.....	1
85	07201104	Screw(M3-0.5X8).....	螺絲.....	2
86	07403786	Speed Connector.....	調速接頭.....	1
87	07403787	Clear Pipe C.Set (For EK).....	吸屑管組(大)(EK專用).....	1
88	07403788	Clear Pipe C.Set (For 02-4LXX).....	吸屑管組(大)(EK段差專用).....	1
89	07403789	Clear Pipe C.Set (For EK).....	吸屑管組(小)(EK專用).....	1
90	07870650	Washer.....	墊片.....	2

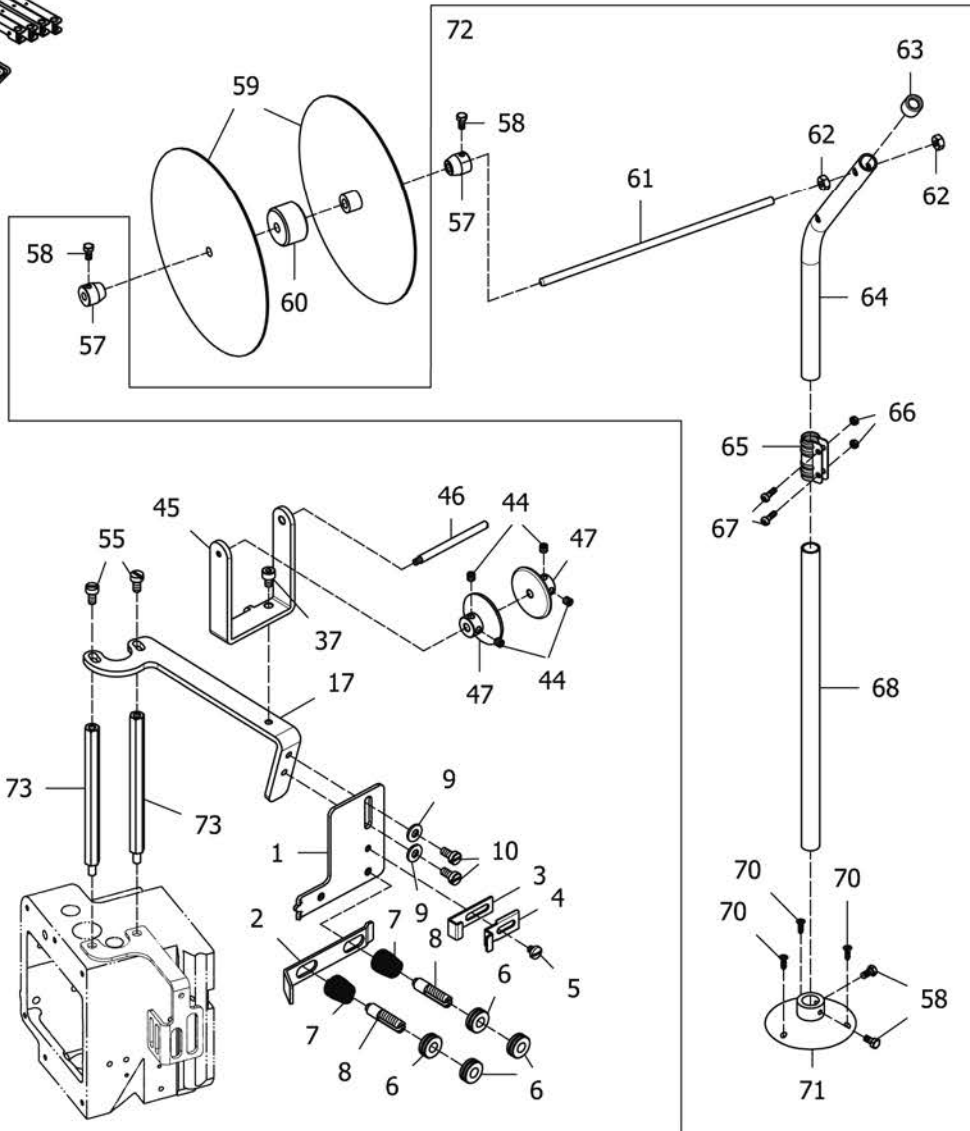
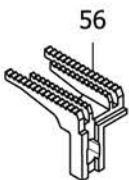
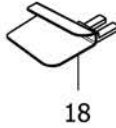
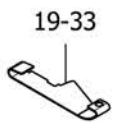
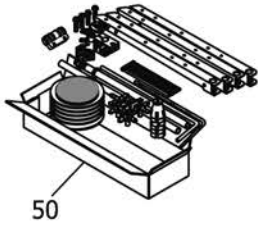
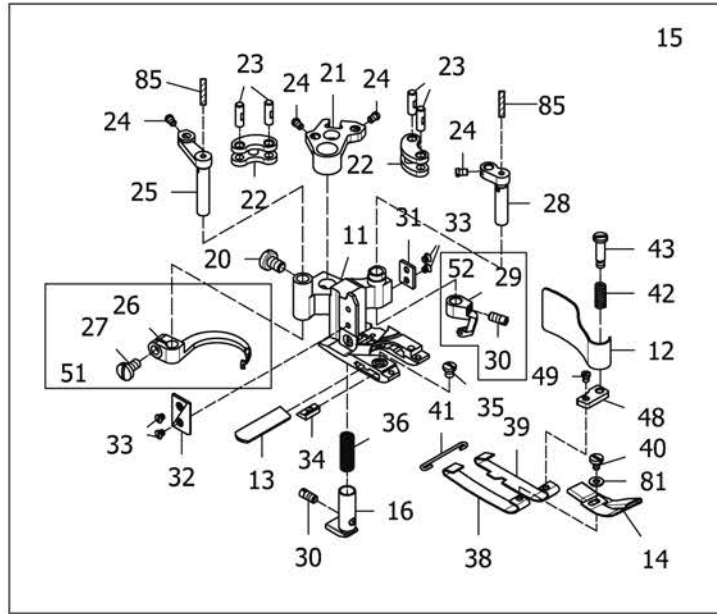
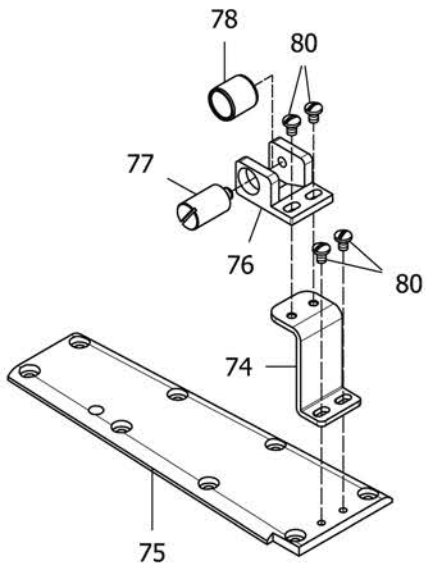

SELECT DEVICE(01-T3)

Ref.	Parts			Amt.
No.	No.	Description	品 名	Req.
1	07402101	Tape Holder.....	織帶固定座.....	1
2	07403802	Tape Tension Disc Clamp.....	張力調整夾板.....	1
3	07402103	Tape Thread Guard (Rear).....	過線架(後).....	1
4	07402104	Tape Thread Guard (Front).....	過線架(前).....	1
5	07402105	Screw (9/64-40X4).....	螺絲.....	1
6	07402106	Spring Disc Nut.....	彈簧調整螺帽.....	4
7	07402107	Tape Spring.....	彈簧.....	2
8	07402108	Tension Post.....	張力彈簧支柱.....	2
9	07872903	Wash.....	墊片.....	2
10	07400302	Screw (11/64-40X7.8).....	螺絲.....	2
11	★	Presser Foot (T3).....	專用押腳(T3).....	1
12	★ 07401828	Chip Guard.....	切角防護片.....	1
13	★ 07400629	Lower Knife.....	下切刀.....	1
14	07403814	Binder.....	喇叭器.....	1
15	★	Presser Foot C. Set.....	押具組.....	1
16	★ 07402116	Yielding Section.....	押具輔助座.....	1
17	07403817	Tape Control Bracket.....	織帶控制架.....	1
18	07403818	Folder.....	導布器.....	1
20	07400615	Screw (11/64-40X6.3).....	螺絲.....	1
21	★ 07400616	Carrier/Hook Driving Segment.....	上勾針驅動扇形片.....	1
22	★ 07400617	Carrier/Hook Driving Lever Link.....	上勾針驅動連桿.....	2
23	★ 07400618	Link Pin.....	連桿插銷.....	4
24	07400619	Screw (3/32-56X3.3).....	螺絲.....	4
25	★ 07400620	Thread Hook Driving Lever.....	勾針驅動槓桿.....	1
26	★ 07400621MF	Top Cover Thread Hook.....	上飾線勾針(長).....	1
27	07400622	Screw (9/64-40X6.8).....	螺絲.....	1
28	★ 07400623	Top Cover Thread Carrier Driving Lever.....	上飾線托架驅動槓桿.....	1
29	★ MF	Top Cover Thread Carrier.....	上飾線勾針(短).....	1
30	07400338	Screw (1/8-44X5).....	螺絲.....	2
31	★ 07400626	Presser Foot Attach Piece (Right).....	押腳連接片(右).....	1
32	★ 07400627	Presser Foot Attach Piece (Left).....	押腳連接片(左).....	1
33	07400628	Screw(3/32-56X1.5).....	螺絲.....	4
34	★ 07400630	Lower Knife Clamp.....	下切刀夾板.....	1
35	07400631	Screw (1/8-44X3.5).....	螺絲.....	1
36	★ 07403836	Yielding Section Spring.....	押具輔助座彈簧.....	1
37	07403012	Screw(M4-0.7X6).....	螺絲(內六角).....	1
38	★ 07403838	Presser Foot Spring Plate (Left).....	押具押板(左).....	1
39	★ 07403839	Presser Foot Spring Plate (Right).....	押具押板(右).....	1
40	07400314	Screw (3/32-56X3.1).....	螺絲.....	1
41	★ 07400638	Spring Plate Holder.....	彈簧片固定座.....	1
42	★ 07400640	Chip Guard Spring.....	切角防護片彈簧.....	1

★ 請參照附件1【針距規格表】

SELECT DEVICE(01-T3)

Ref.	Parts			Amt.
No.	No.	Description	品 名	Req.
43	07400641	Screw (1/8-44X3.4).....	螺絲.....	1
44	07870229	Screw (M4-0.7X4).....	螺絲.....	4
45	07403845	Bracket.....	托架.....	1
46	07403846	Shaft.....	軸心.....	1
47	07403847	Tape Guide.....	織帶導件.....	2
48	★ 07400649	Spacer.....	墊塊.....	1
49	07400650	Screw (3/32-56X4.8).....	螺絲.....	1
50	07401729	Thread Stand.....	線架(五針七線).....	1
51	07400646MF	Top Cover Thread Hook C.Set.....	上飾線勾針組(長).....	1
52	07400647MF	Top Cover Thread Carrier C.Set.....	上飾線勾針組(短).....	1
54	★ 07402907	Main Feed Dog(Coarse Mesh) For Single Cutter.....	單切後勾齒(細齒).....	1
55	07400168	Screw (M4-0.7X8).....	螺絲.....	2
56	★ 07402906	Differential Feed Dog(Coarse Mesh).....	前勾齒(細齒).....	1
57	07421301	Collar.....	軸環.....	2
58	07421302	Screw.....	螺絲.....	4
59	07402206	Tape Reel.....	貼條盤.....	2
60	07402215	Cushion Block.....	墊塊.....	1
61	07421305	Tape Reel Shaft.....	貼條主軸.....	1
62	07421306	Nut.....	螺帽.....	2
63	07421307	Rubber Column Cap.....	橡膠柱頭蓋.....	1
64	07421308	Tape Column Pipe.....	貼條圓柱管.....	1
65	07421309	Tape Column Pipe Connector.....	接頭.....	1
66	07421310	Nut.....	螺帽.....	2
67	07421311	Screw.....	螺絲.....	2
68	07421312	Fixing Lever.....	固定螺桿.....	1
70	07421314	Wood Screw.....	木螺絲.....	3
71	07421315	Tape Holder.....	貼條固定座.....	1
72	07421333	Tape Reel Holder C.Set.....	貼條架組.....	1
73	07403873	Tape Control Bracket Support.....	織帶控制架支撐棒.....	2
74	07403874	Tape Roller Bracket.....	織帶滾輪架.....	1
75	07403875	Cylinder Frame Cover (Upper).....	上蓋.....	1
76	07403876	Tape Roller Holder.....	織帶滾輪座.....	1
77	07403877	Screw (11/64-40X4).....	螺絲.....	1
78	07403878	Roller.....	滾輪.....	1
80	07400355	Screw (1/8-44X4.4).....	螺絲.....	4
81	07403881	Washer.....	墊片.....	1
85	★ 07400651	Green Wool.....	綠色毛線.....	2

★ 請參照附件1【針距規格表】

◎ 補充說明：01-T3押腳更換K19-33、K19-34，可當普通單切押腳功能使用

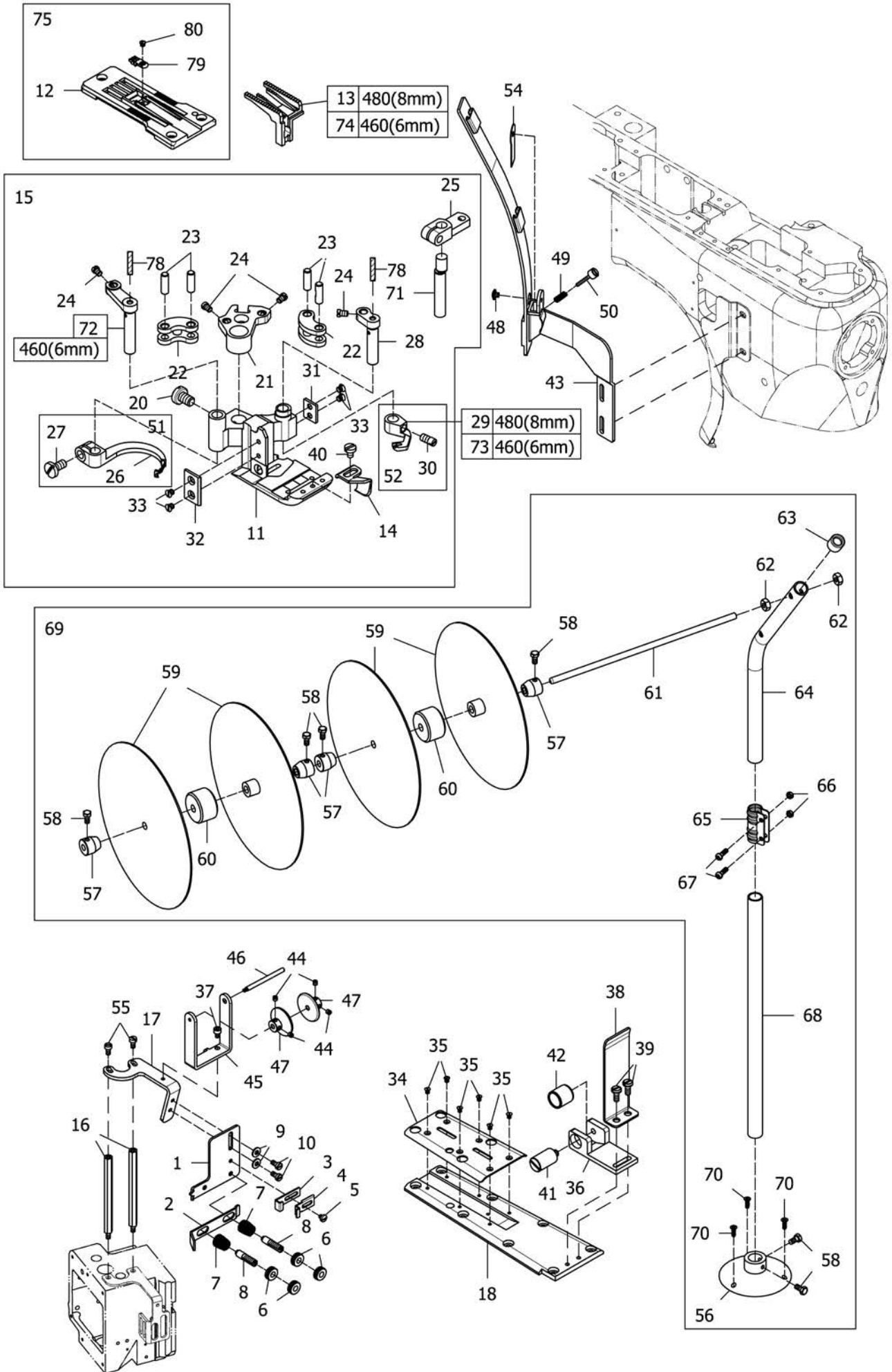

SELECT DEVICE(T4)

Ref.	Parts			Amt.
No.	No.	Description	品名	Req.
1	07402101	Tape Holder.....	織帶固定座.....	1
2	07403802	Tape Tension Disc Clamp.....	張力調整夾板.....	1
3	07402103	Tape Thread Guard (Rear).....	過線架(後).....	1
4	07402104	Tape Thread Guard (Front).....	過線架(前).....	1
5	07402105	Screw (9/64-40X4).....	螺絲.....	1
6	07402106	Spring Disc Nut.....	彈簧調整螺帽.....	4
7	07402107	Tape Spring.....	彈簧.....	2
8	07402108	Tension Post.....	張力彈簧支柱.....	2
9	07872903	Wash.....	墊片.....	2
10	07400302	Screw (11/64-40X7.8).....	螺絲.....	2
11	★	Presser Foot (480.8mm)(460.6mm).....	專用押腳(480.8mm)(460.6mm).....	1
12	★	Stitch Plate (480.8mm)(460.6mm).....	專用針板(480.8mm)(460.6mm).....	1
13	★ 07403913	Differential Feed Dog(480.8mm).....	前送齒(480.8mm).....	1
14	07403914	Fabric Guide.....	壓腳舌.....	1
15	★	Presser Foot C. Set(480.8mm)(460.6mm).....	押具組(480.8mm)(460.6mm).....	1
16	07403873	Tape Control Bracket Support.....	織帶控制架支撐棒.....	2
17	07403917	Tape Control Bracket.....	織帶控制架.....	1
18	07403918	Cylinder Frame Cover (Upper).....	上蓋.....	1
20	07400615	Screw (11/64-40X6.3).....	螺絲.....	1
21	★ 07400616	Carrier/Hook Driving Segment.....	上勾針驅動扇形片.....	1
22	★ 07400617	Carrier/Hook Driving Lever Link.....	上勾針驅動連桿.....	2
23	★ 07400618	Link Pin.....	連桿插銷.....	4
24	07400619	Screw (3/32-56X3.3).....	螺絲.....	4
25	★ 07403445	Driving Lever.....	驅動連桿.....	1
26	★ 07400621MF	Top Cover Thread Hook.....	上飾線過線勾.....	1
27	07400622	Screw (9/64-40X6.8).....	螺絲.....	1
28	★ 07400623	Top Cover Thread Carrier Driving Lever.....	上飾線托架驅動槓桿.....	1
29	★ 07403422MF	Top Cover Thread Carrier.....	上飾線托架.....	1
30	07400338	Screw (1/8-44X5).....	螺絲.....	1
31	★ 07400626	Presser Foot Attach Piece (Right).....	押腳連接片(右).....	1
32	★ 07400627	Presser Foot Attach Piece (Left).....	押腳連接片(左).....	1
33	07400628	Screw(3/32-56X1.5).....	螺絲.....	4
34	07403934	Fabric Edge Guide.....	擋邊.....	1
35	07403935	Screw (3/32-56X3).....	螺絲.....	6
36	07403936	Tape Roller Holder.....	織帶滾輪座.....	1
37	07403012	Screw(M4-0.7X6).....	螺絲(內六角).....	1
38	07403938	Fabric Edge Guide.....	擋邊.....	1
39	07400218	Screw (1/8-44X8).....	螺絲.....	2

★ 請參照附件1【針距規格表】

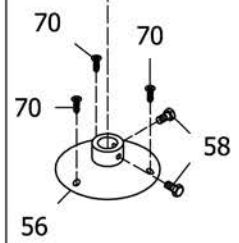
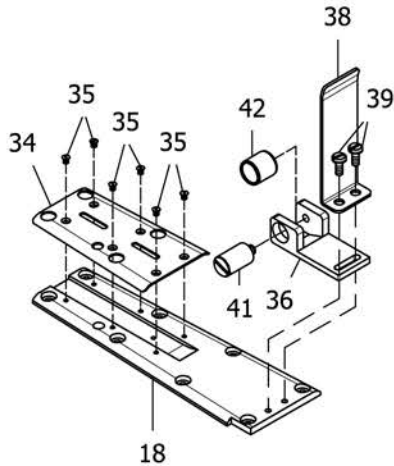
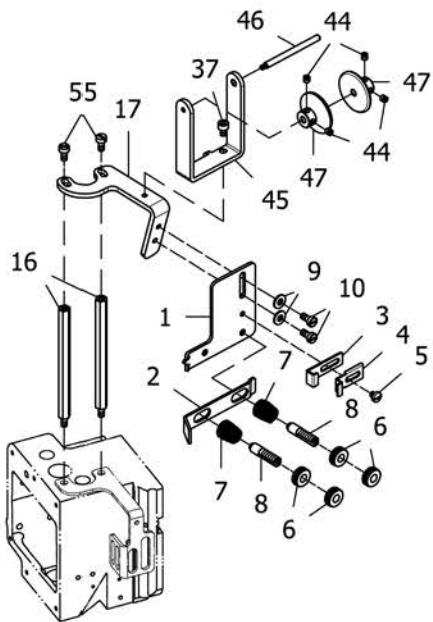
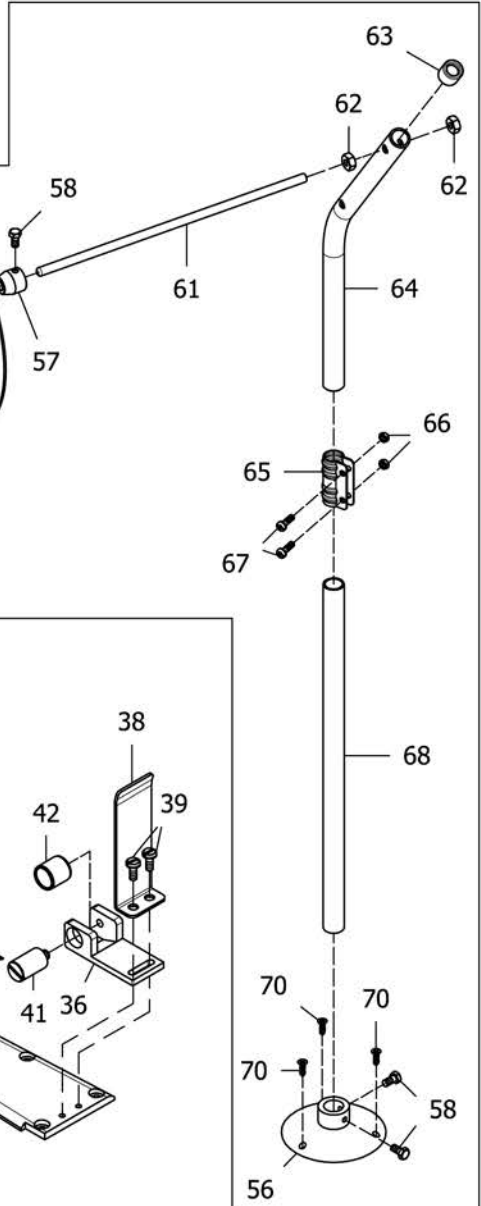
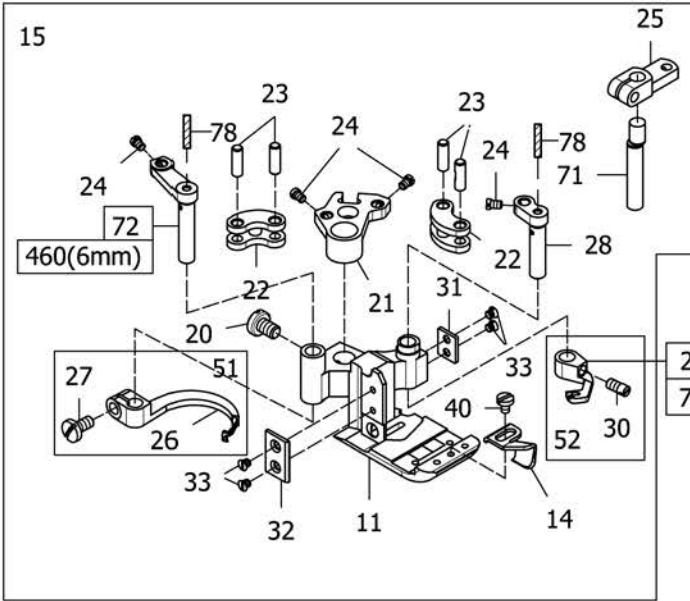
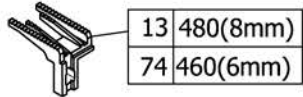
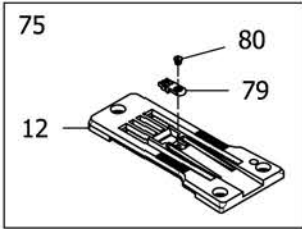

SELECT DEVICE(T4)

Ref.	Parts			Amt.
No.	No.	Description	品 名	Req.
40	07400314	Screw (3/32-56X3.1).....	螺絲.....	1
41	07403877	Screw (11/64-40X4).....	螺絲.....	1
42	07403878	Roller.....	滾輪.....	1
43	07403943	Bracket.....	托架.....	1
44	07870229	Screw (M4-0.7X4).....	螺絲.....	4
45	07403845	Bracket.....	托架.....	1
46	07403846	Shaft.....	軸心.....	1
47	07403847	Tape Guide.....	織帶導件.....	2
48	07403948	Screw (9/64-40X3).....	螺絲.....	1
49	07403949	Spring.....	彈簧.....	1
50	07403950	Screw (M2.3-0.45X16).....	螺絲.....	1
51	07400646MF	Top Cover Thread Hook C.Set.....	上飾線勾針組(長).....	1
52	07400647MF	Top Cover Thread Carrier C.Set.....	上飾線勾針組(短).....	1
54	07403954	Cover Spring.....	彈片.....	1
55	07400168	Screw (M4-0.7X8).....	螺絲.....	2
56	07421315	Tape Holder.....	貼條固定座.....	1
57	07421301	Collar.....	軸環.....	4
58	07421302	Screw.....	螺絲.....	6
59	07402206	Tape Reel.....	貼條盤.....	4
60	07402215	Cushion Block.....	墊塊.....	2
61	07421305	Tape Reel Shaft.....	貼條主軸.....	1
62	07421306	Nut.....	螺帽.....	2
63	07421307	Rubber Column Cap.....	橡膠柱頭蓋.....	1
64	07421308	Tape Column Pipe.....	貼條圓柱管.....	1
65	07421309	Tape Column Pipe Connector.....	接頭.....	1
66	07421310	Nut.....	螺帽.....	2
67	07421311	Screw.....	螺絲.....	2
68	07421312	Fixing Lever.....	固定螺桿.....	1
69	07403969	Tape Reel Holder C.Set.....	貼條架組.....	1
70	07421314	Wood Screw.....	木螺絲.....	3
71	★ 07403450	Thread Hook Driving Lever (For 480 Only)....	勾針驅動槓桿(限用480).....	1
72	07400620	Driving Lever.....	驅動連桿.....	1
73	★MF	Thread Hook Driving Lever.....	勾針驅動槓桿.....	1
74	★ 07403974	Differential Feed Dog(460.6mm).....	前送齒(460.6mm).....	1
75	★	Stitch Plate C.Set.....	針板組.....	1
78	★ 07400651	Green Wool.....	綠色毛線.....	2
79	★	Stitch Plate Tongue.....	針板舌.....	1
80	07400547	Screw (3/32-56X2).....	螺絲.....	1

★ 請參照附件1【針距規格表】

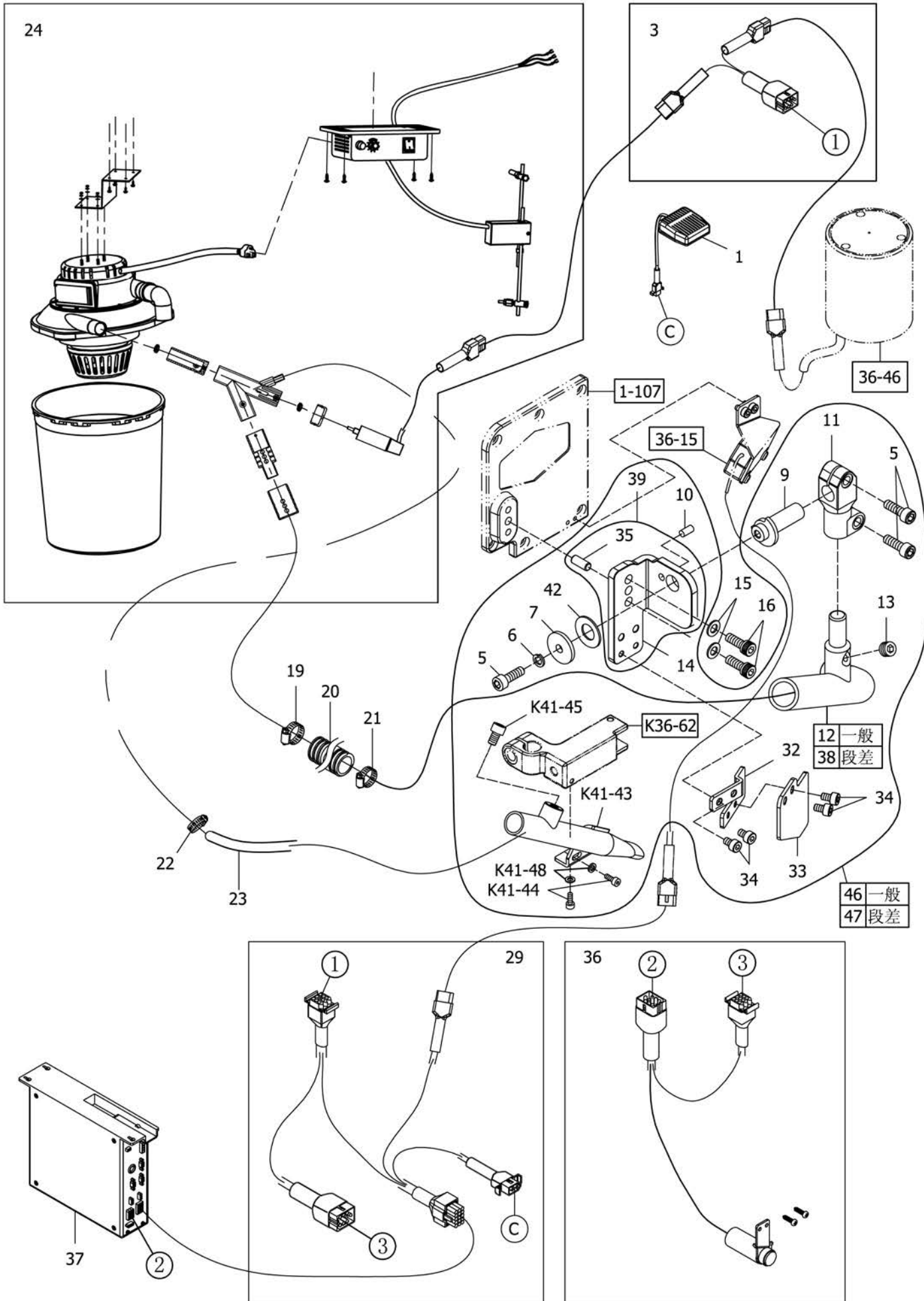

" AW10" DEVICE C.SET (SELECT DEVICE)EK集塵裝置-AW10(選擇配備) **41**

Ref.	Parts			Amt.
No.	No.	Description	品名	Req.
1	07403229	Knee Switch.....	膝動開關.....	1
3	07404103	Relay Line.....	中繼線.....	1
5	07401534	Screw(M5-0.8X16).....	螺絲(內六角).....	3
6	07401548	Spring Washer.....	彈簧防振墊片.....	1
7	07401531	Washer.....	墊片.....	1
9	07401536	Connecting Rod Pin.....	連桿插銷.....	1
10	07401535	Pin.....	插銷.....	1
11	07401533	Connecting Rod.....	連桿.....	1
12	07401527A	Clear Pipe.....	吸屑管(大)(一般用).....	1
13	07401618	Screw (1/8PTX7).....	螺絲.....	1
14	07403765	Bracket.....	托架.....	1
15	07401547	Washer.....	墊片.....	2
16	07404106	Screw(M5-0.8X14).....	螺絲.....	4
19	07401529	Fixed Ring.....	套環.....	2
20	07401506A	Tube.....	風管(大).....	1
21	07401517	Fixed Ring.....	套環.....	1
22	07403224	Fixed Ring.....	套環.....	1
23	07403225	Tube.....	風管(小).....	1
24	07404124	Bucket Collector.....	集塵筒.....	1
29	07403230	Relay Line.....	中繼線.....	1
32	07403769	Safety Plate Support.....	護目鏡固定座.....	1
33	07403770	Safety Plate.....	護目鏡片.....	1
34	07403012	Screw(M4-0.7X6).....	螺絲.....	4
35	07403643	Pin.....	插銷.....	1
36	07403776	Knife Switch C.Set.....	切刀開關組.....	1
37	07401242	Control Box.....	控制箱.....	1
38	07401560	Clear Pipe (For 02-4LXX).....	吸屑管(大)(段差用).....	1
39	07403779	Bracket C.Set.....	托架組.....	1
42	07401562	Conical Spring Washer.....	錐形彈簧墊圈.....	1
43	07403784	Clear Pipe.....	吸屑管.....	1
44	07201104	Screw(M3-0.5X8).....	螺絲.....	2
45	07403254	Screw(M5-0.8X8).....	螺絲.....	1
46	07404146	Clear Pipe C.Set (For EK).....	吸屑管組(大)(EK專用).....	1
47	07404147	Clear Pipe C.Set (For 02-4LXX).....	吸屑管組(大)(EK段差專用).....	1
48	07870650	Washer.....	墊片.....	2

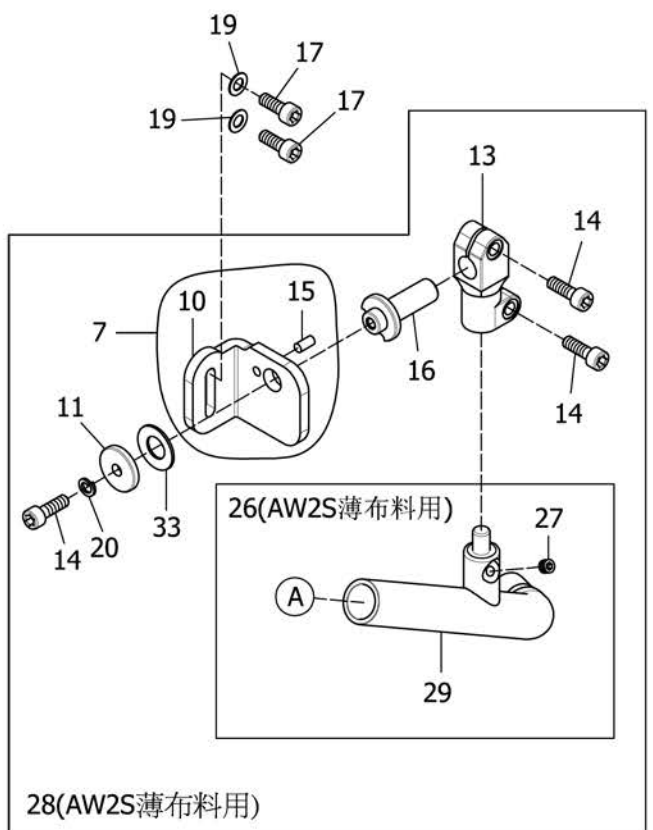
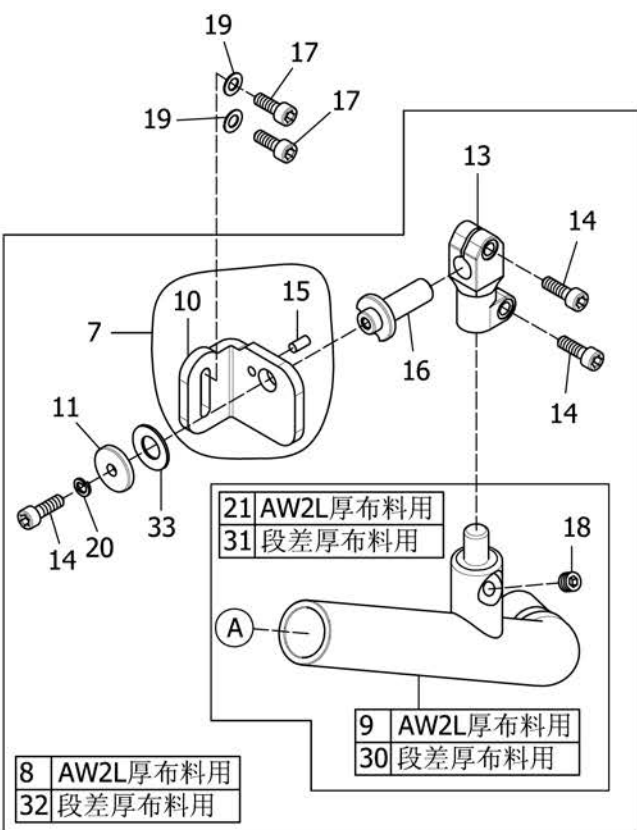
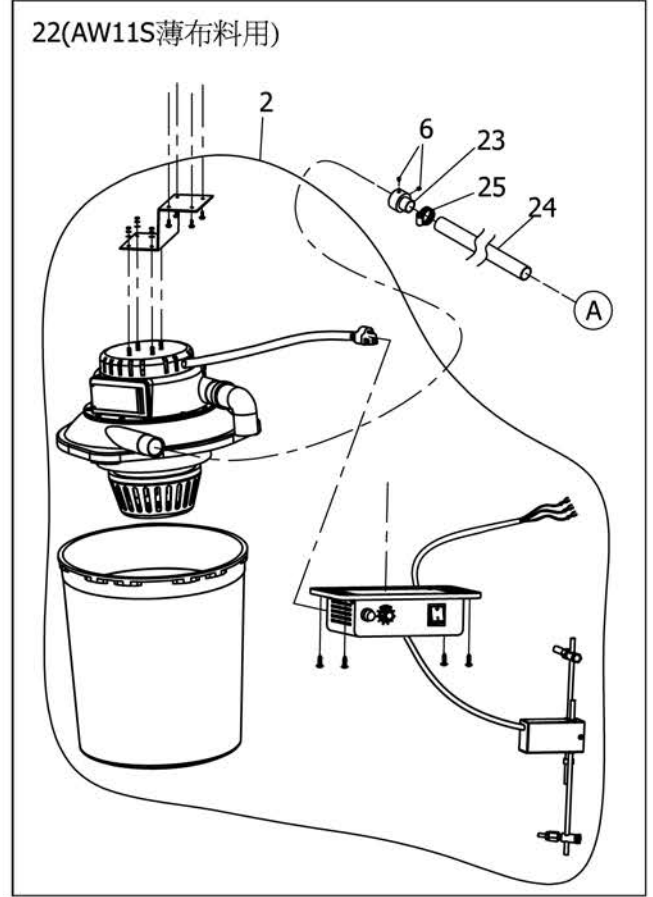
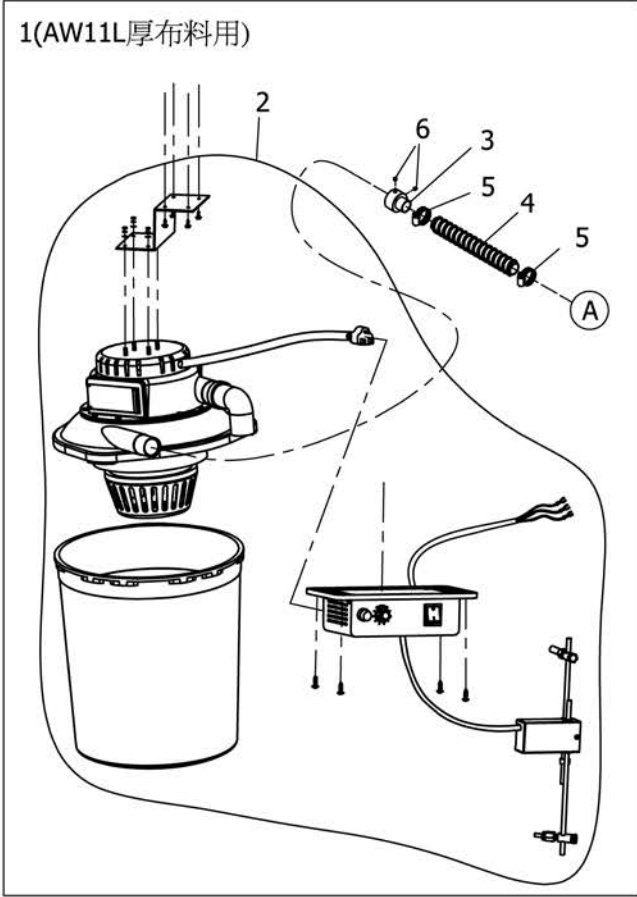

筒型吸布屑組-AW11L、AW11S(選擇配備)

Ref. No.	Parts No.	Description	品名	Amt. Req.
1	07401601	AW Case C.Set.....	吸風箱組(AW11L厚布料用)	1
2	07404202	Bucket Collector.....	集塵筒.....	1
3	07404203	Connect Tube.....	接管.....	1
4	07401506A	Tube.....	風管(大).....	1
5	07401517	Fixed Ring.....	套環.....	2
6	07401626	Screw (M6-1X5).....	螺絲.....	2
7	07401559	Bracket C.Set.....	托架組.....	1
8	07401608	AW Tube System.....	吸風管組(AW11L厚布料用)	1
9	07401527A	Clear Pipe.....	吸屑管(大)(一般用).....	1
10	07401530	Bracket.....	托架.....	1
11	07401531	Washer.....	墊片.....	1
13	07401533	Connecting Rod.....	連桿.....	1
14	07401534	Screw (M5-0.8X16).....	螺絲.....	3
15	07401535	Pin.....	插銷.....	1
16	07401536	Connecting Rod Pin.....	連桿插銷.....	1
17	07804106	Screw (M5-0.8X14).....	螺絲.....	2
18	07401618	Screw (1/8PTX7).....	螺絲.....	1
19	07401547	Washer.....	墊片.....	2
20	07401548	Washer.....	彈簧防振墊片.....	1
21	07401621A	Clear Pipe C.Set.....	吸屑管組(AW11L厚布料用)	1
22	07401633	AW Case C.Set.....	吸風箱組(AW11S薄布料用)	1
23	07404223	Connect Tube.....	接管.....	1
24	07401554	Tube.....	風管(小).....	1
25	07401504	Fixed Ring.....	套環.....	1
26	07401631	Clear Pipe C.Set.....	吸屑管組(AW11S薄布料用)	1
27	07401211	Screw (M5-0.8X6).....	螺絲.....	1
28	07401632	AW Tube System.....	吸風管組(AW11S薄布料用)	1
29	07401551	Clear Pipe.....	吸屑管(小).....	1
30	07401560	Clear Pipe (For 02-4LXX).....	吸屑管(大)(段差用).....	1
31	07401639	Clear Pipe C.Set (For 02-4LXX).....	吸屑管組(AW2L段差用).....	1
32	07401640	AW Tube System (For 02-4LXX).....	吸風管組(AW2L段差用).....	1
33	07401562	Conical Spring Washer.....	錐形彈簧墊圈.....	1

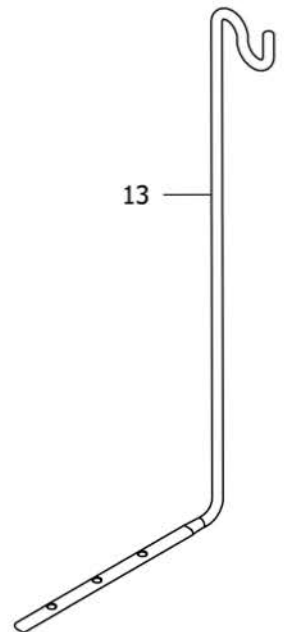
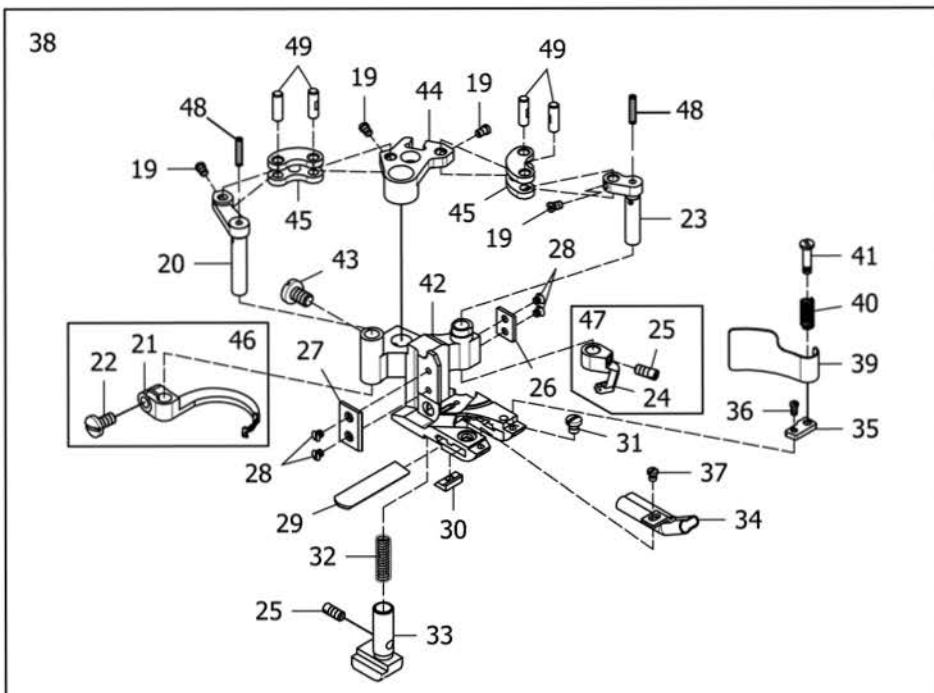
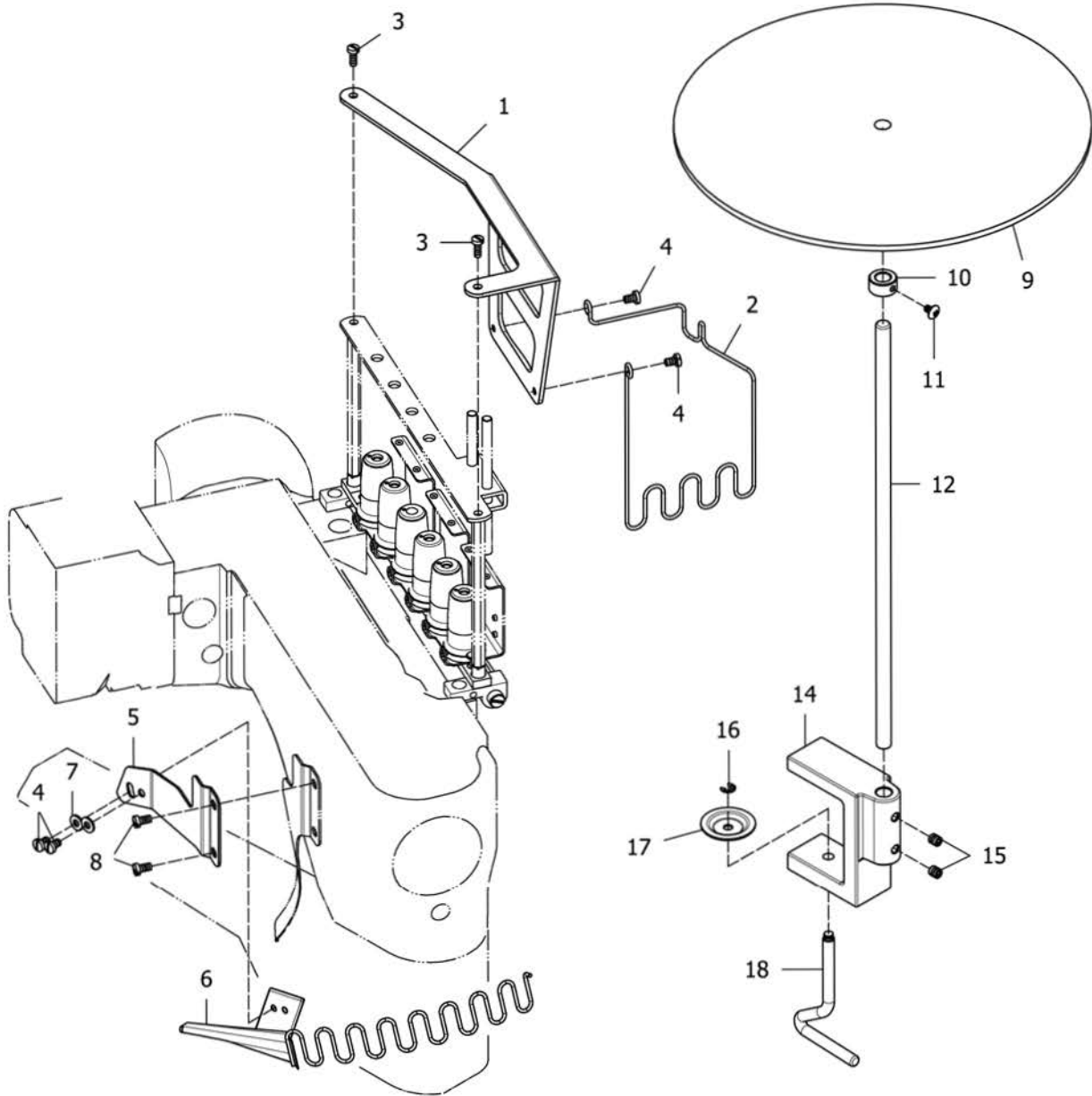

SELECT DEVICE(T5)

Ref.	Parts			Amt.
No.	No.	Description	品名	Req.
1	07404301	Binding Cloth Guider Holder.....	滾條布導架固定座.....	1
2	07404302	Binding Cloth Guider.....	滾條布導架.....	1
3	07400103	Screw(11/64-40X10.5).....	螺絲.....	2
4	07400109	Screw (11/64-40X6.5).....	螺絲.....	4
5	07404305	Binder Holder.....	喇叭包邊器固定座.....	1
6	07404306	Binder.....	喇叭包邊器.....	1
7	07872903	Wash.....	墊片.....	2
8	07400302	Screw (11/64-40X7.8).....	螺絲.....	2
9	07872706A	Tope Disc.....	布條盤.....	1
10	07404310	Collar	軸環.....	1
11	07404311	Screw (M2.3-0.45X16).....	螺絲.....	1
12	07404312	Tape Disc Post.....	布條盤軸.....	1
13	07404313	Tape Guide.....	織帶導引支架.....	1
14	07872703A	Fixture.....	固定夾架.....	1
15	07872705A	Screw(M6-1×6).....	螺絲.....	2
16	07872701A	Pin.....	插銷.....	1
17	07872702A	Fixed Disc.....	固定圓盤.....	1
18	07872704A	Fixing Lever.....	固定螺桿.....	1
19	07400619	Screw (3/32-56X3.3).....	螺絲.....	4
20	★ 07400620	Thread Hook Driving Lever.....	勾針驅動槓桿.....	1
21	★ 07400621MF	Top Cover Thread Hook.....	上飾線勾針(長).....	1
22	07400622	Screw (9/64-40X6.8).....	螺絲.....	1
23	★ 07400623	Top Cover Thread Carrier Driving Lever.....	上飾線托架驅動槓桿.....	1
24	★ MF	Top Cover Thread Carrier.....	上飾線勾針(短).....	1
25	07400338	Screw (1/8-44X5).....	螺絲.....	2
26	★ 07400626	Presser Foot Attach Piece (Right).....	押腳連接片(右).....	1
27	★ 07400627	Presser Foot Attach Piece (Left).....	押腳連接片(左).....	1
28	07400628	Screw(3/32-56X1.5).....	螺絲.....	5
29	★ 07400629	Lower Knife.....	下切刀片.....	1
30	★ 07400630	Lower Knife Clamp.....	下切刀夾板.....	1
31	07400631	Screw (1/8-44X3.5).....	螺絲.....	1
32	★ 07400632	Yielding Section Spring.....	押具輔助座彈簧.....	1
33	★ 07404333	Yielding Section.....	押具輔助座.....	1
34	07404334	Lap Former Guide.....	導布器.....	1
35	★ 07400649	Spacer.....	墊塊.....	1
36	07400650	Screw (3/32-56X4.8).....	螺絲.....	1
37	07400637	Screw (3/32-56X2.6).....	螺絲.....	1
38	★	Presser Foot C. Set (T5).....	押具組(T5).....	1
39	★ 07401828	Chip Guard.....	切角防護片.....	1

★ 請參照附件1【針距規格表】

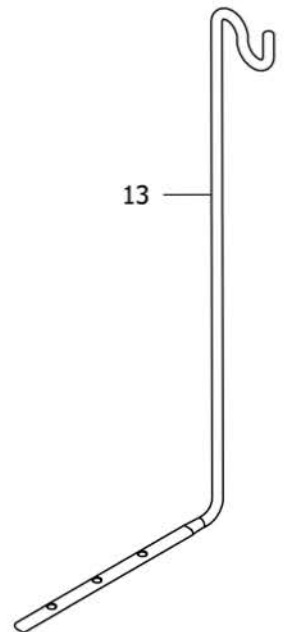
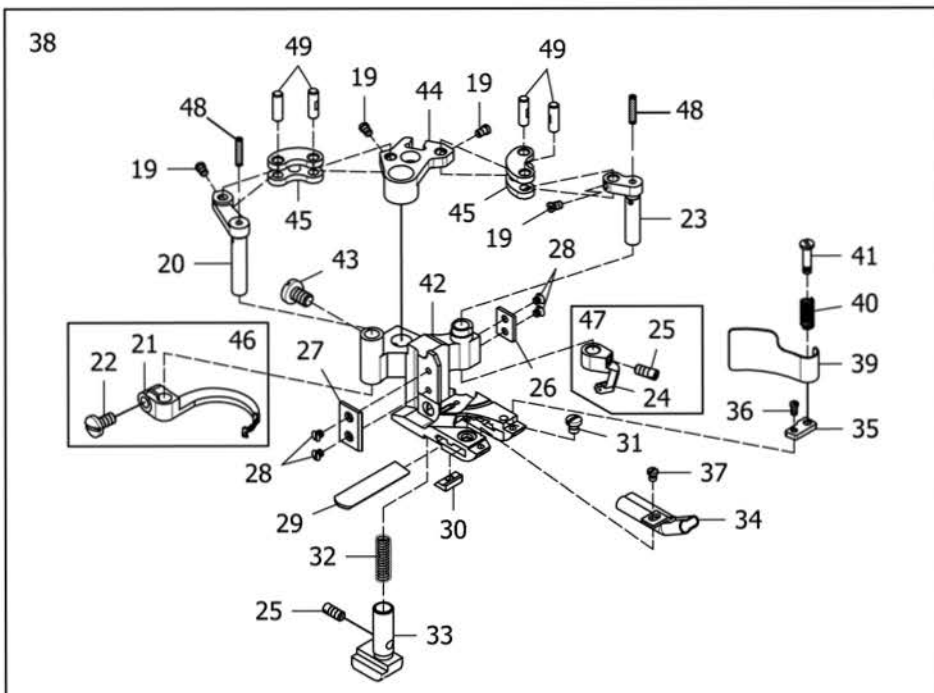
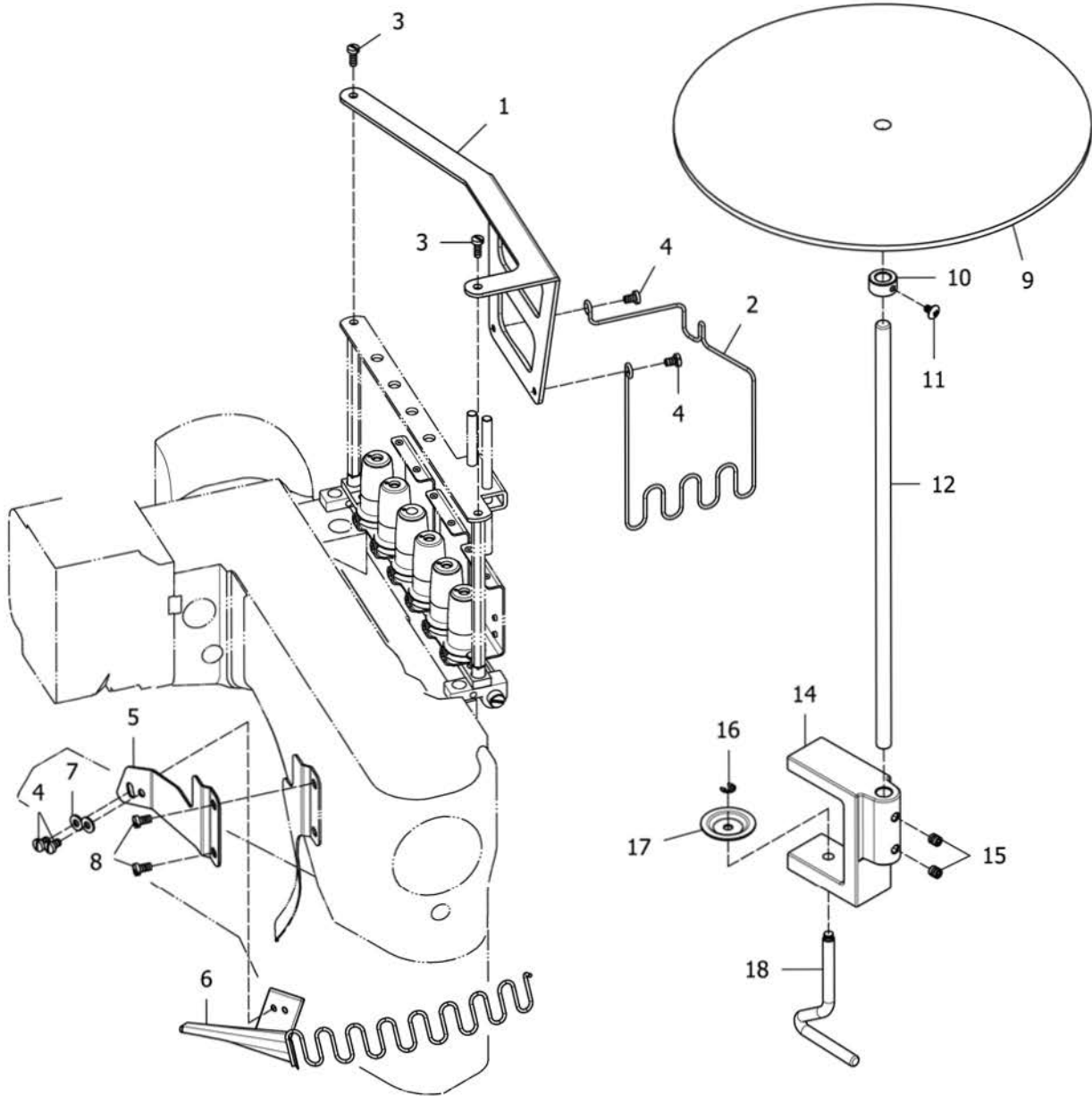

SELECT DEVICE(T5)

Ref.	Parts			Amt.
<u>No.</u>	<u>No.</u>	<u>Description</u>	<u>品 名</u>	<u>Req.</u>
40	★ 07400640	Chip Guard Spring.....	切角防護片彈簧.....	1
41	07400641	Screw (1/8-44X3.4).....	螺絲.....	1
42	★	Presser Foot.....	押腳.....	1
43	07400615	Screw (11/64-40X6.3).....	螺絲.....	1
44	★ 07400616	Carrier/Hook Driving Segment.....	上勾針驅動扇形片.....	1
45	★ 07400617	Carrier/Hook Driving Lever Link.....	上勾針驅動連桿.....	2
46	07400646MF	Top Cover Thread Hook C.Set.....	上飾線勾針組(長).....	1
47	07400647MF	Top Cover Thread Carrier C.Set.....	上飾線勾針組(短).....	1
48	★ 07400651	Green Wool.....	綠色毛線.....	2
49	★ 07400618	Link Pin.....	連桿插銷.....	4
	★ 請參照附件1【針距規格表】			

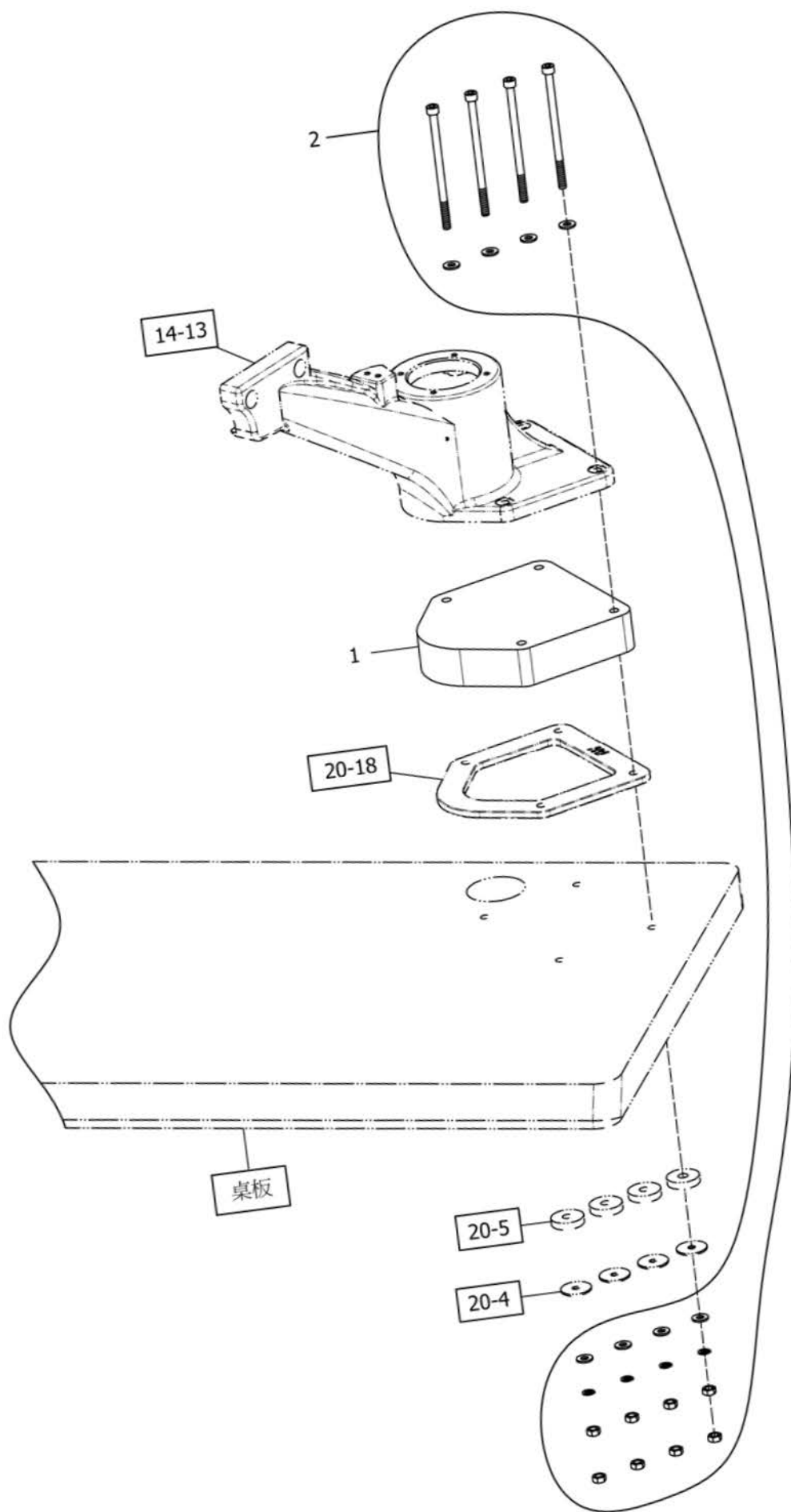

SELECT DEVICE (Motor Support)

底座增高選配件 **45**

Ref.	Parts			Amt.
<u>No.</u>	<u>No.</u>	<u>Description</u>	<u>品 名</u>	<u>Req.</u>
1	07404501	Motor Support.....	底座增高板.....	1
2	07404502	Screw C. Set.....	螺絲組.....	1

技術通報

〈平面式桌板・車架及相關配件安裝位置示意圖〉

2010年06月22日 版本

單位 = mm

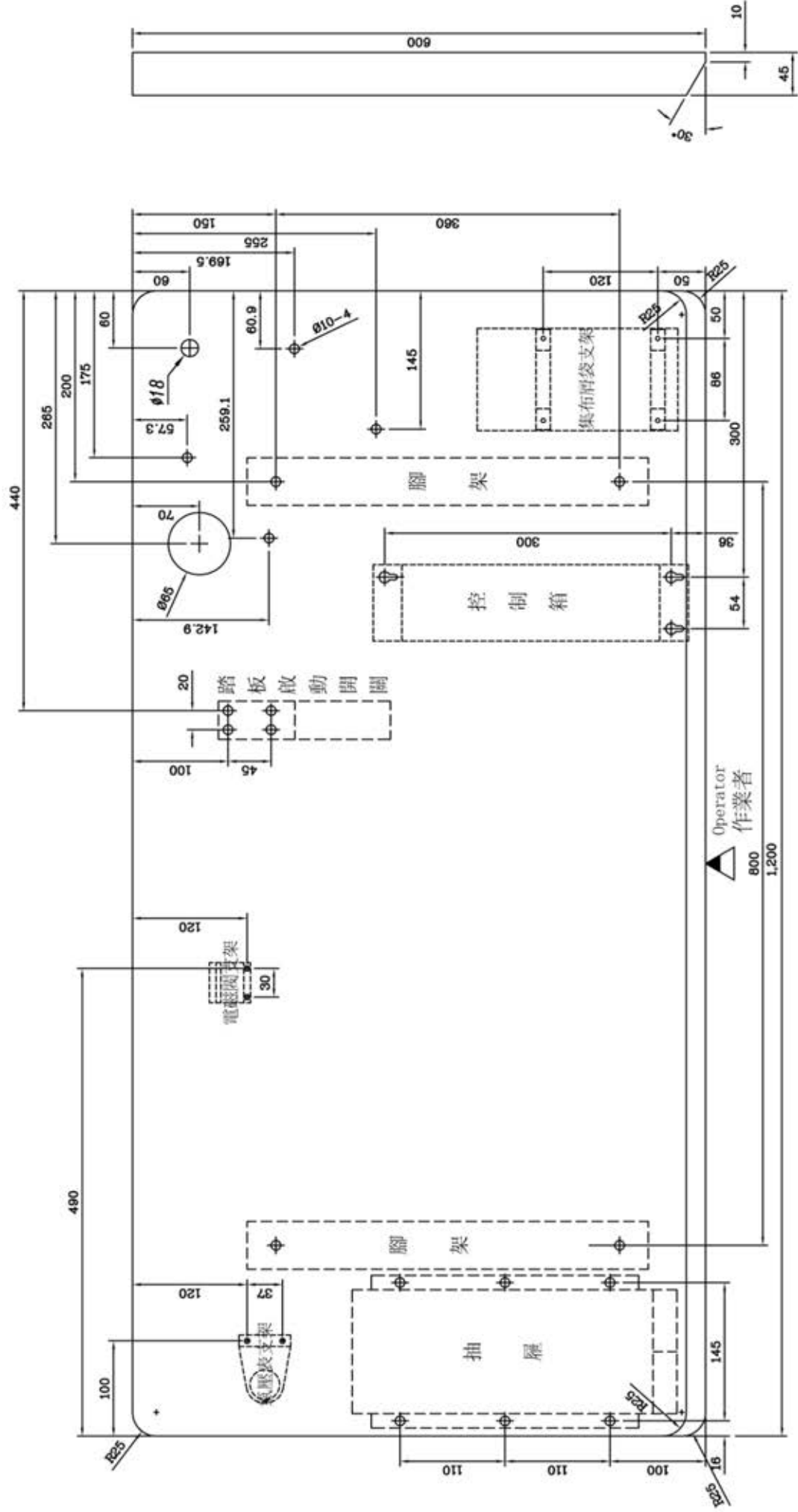

附件 1

STITCH LENGTH SPECIFICATION

針具規格表

注意事項：

- **【押具整組】**：包含 1 ~ 25 的零件，下單時請特別注意，避免重複訂購。
- **產品使用注意事項**：當原使用產品的規格，欲變更其他規格；
例如：4針5.2mm變更為4針6.0mm，必須使用校車定規組由專業技師調校。

針具規格	Main Parts Models	1	2	3	4	5	6	7	8	9	10	11	12	13	14	15	16	17	18	19	20	21	22	23	24	25		
		Driving Segment	Driving Lever Link	Link Pin	Thread Hook Driving Lever	Thread Hook	Thread Carrier Driving Lever	Thread Carrier	Attach Piece (Right)	Attach Piece (Left)	Lower Knife	Lower Knife Clamp		Yielding Section	Spring Plate (Left)-Short	Spring Plate (Right)-Short	Spring Plate (Left)-Long	Spring Plate (Right)-Long		Chip Guard		Spacer	Green Wool	Presser Foot Tongue	Driving Lever	Driving Lever		
		1.上勾針驅動扇形片	2.上勾針驅動連桿	3.連桿插銷	4.勾針驅動槓桿	5.上飾線勾針(長)	6.上飾線托架驅動槓桿	7.上飾線勾針(短)	8.押腳連接片(右)	9.押腳連接片(左)	10.下切刀片	11.下切刀夾板	12.押具輔助座彈簧	13.押具輔助座	14.押具押板(左)-短	15.押具押板(右)-短	16.押具押板(左)-長	17.押具押板(右)-長	18.彈簧固定座	19.切角防護片	20.切角防護片彈簧	21.墊塊	22.綠色毛線	23.導布板	24.勾針驅動槓桿	25.驅動連桿		
448	FW-740TA-448-01	07400616	07400617	07400618	07400620	07400621	07400623	07400624-452MF	07400626	07400627	07400629	07400630	07400632	07400633	07400635A	07400636A	07401924	07401925	07400638	07400639	07400640	07400649	07400651	x	x	x		
	FW-740TA-448-02	"	"	"	"	"	"	"	"	"	"	"	"	07401821	07401824	07401825	07401914	07401915	"	07401828	"	"	"	07401822	x	x		
	FW-740TA-448-02R	"	"	"	"	"	"	"	"	"	"	"	"	07402116	"	"	"	"	"	"	"	"	"	"	"	x	x	
452	FW-740TA-452-01	07400616	07400617	07400618	07400620	07400621	07400623	07400624-452MF	07400626	07400627	07400629	07400630	07400632	07400633	07400635A	07400636A	07401924	07401925	07400638	07400639	07400640	07400649	07400651	x	x	x		
	FW-740TA-452-02	"	"	"	"	"	"	"	"	"	"	"	"	07401821	07401824	07401825	07401914	07401915	"	07401828	"	"	"	07401822	x	x		
	FW-740TA-452-02R	"	"	"	"	"	"	"	"	"	"	"	"	07402116	"	"	"	"	"	"	"	"	"	"	"	x	x	
	FW-740TA-452-02H	"	"	"	"	"	"	"	"	"	07402617	"	"	07401821	07402624	07402625	07402624	07402625	"	"	"	"	"	"	"	x	x	
	FW-740TA-452-02H(特厚寬刀)	"	"	"	"	"	"	"	"	"	"	"	"	07401821	07402651	07402652	07402651	07402652	"	"	"	"	"	"	"	x	x	
	FW-740TA-452-02H(特厚窄刀)	"	"	"	"	"	"	"	"	"	07400629	"	"	07401821	"	"	"	"	"	"	"	"	"	"	"	"	x	x
	FW-740TA-452-02RH	"	"	"	"	"	"	"	"	"	07402617	"	"	07402116	07402624	07402625	07402624	07402625	"	"	"	"	"	"	"	x	x	
	FW-740TA-452-02-T1(5mm)	"	"	"	"	"	"	"	"	"	"	07402113	"	"	07402116	07401824	07401825	07401914	07401915	"	07402112	"	x	"	"	x	x	
	FW-740TA-452-02-T1(7mm)	"	"	"	"	"	"	"	"	"	"	"	"	"	07402116	"	"	"	"	"	"	"	x	"	"	"	x	x
	FW-740TA-452-01-T2	x	x	x	x	x	x	x	"	"	07400629	"	"	07400633	07402219	07402220	07402219	07402220	"	07402216	"	x	"	x	"	x	x	
	FW-740TA-452-02-T2	x	x	x	x	x	x	x	"	"	"	"	"	07401821	07402819	07402820	07402819	07402820	"	"	"	x	"	07401822	x	x		
	FW-740TA-452-02R-T2	x	x	x	x	x	x	x	"	"	"	"	"	07402116	"	"	"	"	"	"	"	x	"	"	"	x	x	
	FW-740TA-452-02H-T2	x	x	x	x	x	x	x	"	"	07402617	"	"	07401821	"	"	"	"	"	"	"	x	"	"	"	x	x	
	FW-740TA-452-01-T3	07400616	07400617	07400618	07400620	07400621	07400623	07400624-452MF	"	"	07400629	"	07403836	07402116	07403838.83	07403839	07403838.83	07403839	"	07401828	"	07400649	"	x	"	x	x	
	FW-740TA-452-01-T5	"	"	"	"	"	"	"	"	"	"	"	07400632	07404333	x	x	x	x	"	"	"	"	"	"	x	"	x	x
	FW-740TA-452-01-S	"	"	"	"	"	"	"	"	"	"	07402302	"	07400633	07400635A	07400636A	07401924	07401925	"	07400639	"	"	"	"	x	"	x	x
FW-740TA-452-02-S	"	"	"	"	"	"	"	"	"	"	07400630	"	07401821	07401824	07401825	07401914	07401915	"	07401828	"	"	"	"	07401822	x	x		
FW-740TA-452-01-DS	"	"	"	"	"	"	"	"	"	"	"	"	07400633	07400635A	07400636A	07401924	07401925	"	07400639	"	"	"	"	x	"	x	x	
FW-740TA-452-02-4L10	"	"	"	"	"	"	07403512	"	07403515	"	"	"	07403521	07403524	07403525	07403524	07403525	"	07403528	"	x	"	07403556	x	x	x		
FW-740TA-452-02-4L15	"	"	"	"	"	"	"	"	"	"	"	"	07403521	"	"	"	"	"	"	"	"	x	"	"	"	x	x	
FW-740TA-452-02-4L20	"	"	"	"	"	"	"	"	"	"	"	"	07403565	07403566	07403567	07403566	07403567	"	"	"	x	"	"	"	x	x		
552	FW-740TA-552-01	07400616	07400617	07400618	07400620	07400621	07400623	07400624-452MF	07400626	07400627	07400629	07400630	07400632	07400633	07400635A	07400636A	07401924	07401925	07400638	07400639	07400640	07400649	07400651	x	x	x		
	FW-740TA-552-02	"	"	"	"	"	"	"	"	"	"	"	"	07401821	07401824	07401825	07401914	07401915	"	07401828	"	"	"	07401822	x	x		
	FW-740TA-552-02R	"	"	"	"	"	"	"	"	"	"	"	"	07402116	"	"	"	"	"	"	"	"	"	"	"	"	x	x

- 【押具整組】：包含 1 ~ 25 的零件，下單時請特別注意，避免重複訂購。
- 產品使用注意事項：當原使用產品的規格，欲變更其他規格；例如：4針5.2mm變更為4針6.0mm，必須使用校車定規組由專業技師調校。

(V 為選擇配備)

附件1

針具規格	Main Parts Models																														
		押具整組	真針	假針	針鑷	針鑷組	針板組	針板	針板舌	後送齒	前送齒	針檔(後)	導布器	導布器座	導布器彈簧片	導布器滑軌(左)	導布器滑軌(右)	下巴蓋板	上蓋	上刀片支架	上刀片	上切刀固定座	導布蓋	控制架	織帶喇叭組	貼條喇叭組	T.T反打結繡送料機(含控制箱)	AW1吸風組	AW2箱型吸風組		
448	FW-740TA-448-01	07400613-448	07400541-448	07400542-448	07400540-448	07400531-448	07400532A-448	07400544A-448	07400546-448	07401008	07401007	07401010	x	x	x	x	x	07400216	07400742	07400744	07400745	07400145	07400167A	x	x	x	V	V			
	FW-740TA-448-02	07401801-448	"	"	"	"	07401852A-448	07401842A-448	"	07401841	"	"	07401831	07401834	07401835	07401836	07401837	07401839	x	"	"	"	"	x	x	x	V	V			
	FW-740TA-448-02R	07402501-448	"	"	"	"	07400532A-448	07400544A-448	"	07401008	"	"	"	"	"	"	"	"	x	"	"	"	"	x	x	x	V	V			
452	FW-740TA-452-01	07400613-452	07400541-452	07400542-452	07400540-452	07400531-452	07400532A-452	07400544A-452	07400546-452	07401008	07401007	07401010	x	x	x	x	x	07400216	07400742	07400744	07400745	07400145	07400167A	x	x	x	V	V			
	FW-740TA-452-02	07401801-452	"	"	"	"	07401852A-452	07401842A-452	"	07401841	"	"	07401831	07401834	07401835	07401836	07401837	07401839	x	"	"	"	"	x	x	x	V	V			
	FW-740TA-452-02R	07402501-452	"	"	"	"	07400532A-452	07400544A-452	"	07401008	"	"	"	"	"	"	"	"	x	"	"	"	"	x	x	x	V	V			
	FW-740TA-452-02H	07402601-452	"	"	"	"	07401852A-452	07401842A-452	"	07401841	"	07402631	"	"	"	"	"	"	x	07402636	07402637	07402638	"	"	x	x	x	V	V		
	FW-740TA-452-02H(特厚寬刀)	07404001-452	"	"	"	"	"	"	"	"	"	"	"	"	"	"	"	"	x	"	"	"	"	x	x	x	V	V			
	FW-740TA-452-02H(特厚窄刀)	07404002-452	"	"	"	"	"	"	"	"	"	"	"	"	"	"	"	"	x	"	"	"	"	x	x	x	V	V			
	FW-740TA-452-02RH	07402701-452	"	"	"	"	07400532A-452	07400544A-452	"	07401008	"	"	"	"	"	"	"	"	x	"	"	"	"	x	x	x	V	V			
	FW-740TA-452-02-T1(5mm)	07402157-452	"	"	"	"	07401852A-452	07401842A-452	"	07401841	"	"	07401831	"	"	"	"	"	x	07402114	07400744	07400745	"	07402117A	V	x	V	V	V		
	FW-740TA-452-02-T1(7mm)	07402115-452	"	"	"	"	"	"	"	"	"	"	"	"	"	"	"	"	x	"	"	"	"	"	V	x	V	V	V		
	FW-740TA-452-01-T2	07402218-452	07402240-452	"	"	"	07400532A-452	07400544A-452	"	07401008	"	"	x	x	x	x	x	x	07400216	07400742	"	"	07402212	07400167A	x	V	x	V	V		
	FW-740TA-452-02-T2	07402818-452	"	"	"	"	07401852A-452	07401842A-452	"	07401841	"	"	07401831	07401834	07401835	07401836	07401837	07401839	x	"	"	"	"	x	V	x	V	V			
	FW-740TA-452-02R-T2	07404005-452	"	"	"	"	07400532A-452	07400544A-452	"	07401008	"	"	"	"	"	"	"	"	x	"	"	"	"	x	V	x	V	V			
	FW-740TA-452-02H-T2	07404006-452	"	"	"	"	07401852A-452	07401842A-452	"	07401841	"	07402631	"	"	"	"	"	"	x	07402636	07402637	07402638	"	"	x	V	x	V	V		
	FW-740TA-452-01-T3	07403815-452	07400541-452	"	"	"	07400532A-452	07400544A-452	"	07402907	07402906	"	x	x	x	x	x	x	07403875	07400742	07400744	07400745	07400145	07403817	x	x	V	V	V		
	FW-740TA-452-01-T5	07404338-452	"	"	"	"	"	"	"	07401008	07401007	"	x	x	x	x	x	x	07400216	"	"	"	"	07400167A	x	x	x	V	V		
	FW-740TA-452-01-S	07402306-452	"	"	"	"	"	"	"	07401008	"	"	x	x	x	x	x	x	"	"	"	"	"	"	x	x	x	V	V		
FW-740TA-452-02-S	07402307-452	"	"	"	"	07401852A-452	07401842A-452	"	07401841	"	"	07401831	07401834	07401835	07401836	07401837	07401839	x	"	"	"	"	"	x	x	x	V	V			
FW-740TA-452-01-DS	07402408-452	07402405-452	07402506-452	"	"	07400532A-452	07400544A-452	"	07402403	07402407	"	x	x	x	x	x	x	07400216	"	"	"	"	"	x	x	x	V	V			
FW-740TA-452-02-4L10	07403501-452	07400541-452	07400542-452	"	"	07403545-452	07403546-452	"	07403544-4L10	07403543-4L10	"	07403531	07403534	07401835	07401836	07401837	07401839	x	"	"	"	07403551	"	x	x	x	V	V			
FW-740TA-452-02-4L15	07403580-452	"	"	"	"	07403576-452	07403578-452	"	07403544-4L15	07403543-4L15	"	"	"	"	"	"	"	x	"	"	"	"	"	x	x	x	V	V			
FW-740TA-452-02-4L20	07403581-452	"	"	"	"	07403577-452	07403579-452	"	07403544-4L20	07403543-4L20	"	"	"	"	"	"	"	x	"	"	"	"	"	x	x	x	V	V			
552	FW-740TA-552-01	07400613-552	07400541-552	07400542-552	07400540-552	07400531-552	07400532A-552	07400544A-552	07400546-552	07401008	07401007	07401010	x	x	x	x	x	07400216	07400742	07400744	07400745	07400145	07400167A	x	x	x	V	V			
	FW-740TA-552-02	07401801-552	"	"	"	"	07401852A-552	07401842A-552	"	07401841	"	"	07401831	07401834	07401835	07401836	07401837	07401839	x	"	"	"	"	x	x	x	V	V			
	FW-740TA-552-02R	07402501-552	"	"	"	"	07400532A-552	07400544A-552	"	07401008	"	"	"	"	"	"	"	"	x	"	"	"	"	x	x	x	V	V			

- 【押具整組】：包含 1 ~ 25 的零件，下單時請特別注意，避免重複訂購。
- 產品使用注意事項：當原使用產品的規格，欲變更其他規格；例如：4針5.2mm變更為4針6.0mm，必須使用校車定規組由專業技師調校。

針具規格	Main Parts Models	1	2	3	4	5	6	7	8	9	10	11	12	13	14	15	16	17	18	19	20	21	22	23	24	25	
		Driving Segment	Driving Lever Link	Link Pin	Thread Hook Driving Lever	Thread Hook	Thread Carrier Driving Lever	Thread Carrier	Attach Piece (Right)	Attach Piece (Left)	Lower Knife	Lower Knife Clamp		Yielding Section	Spring Plate (Left)-Short	Spring Plate (Right)-Short	Spring Plate (Left)-Long	Spring Plate (Right)-Long		Chip Guard		Spacer	Green Wool	Presser Foot Tongue	Driving Lever	Driving Lever	
		1.上勾針驅動扇形片	2.上勾針驅動連桿	3.連桿插銷	4.勾針驅動槓桿	5.上飾線勾針(長)	6.上飾線托架驅動槓桿	7.上飾線勾針(短)	8.押腳連接片(右)	9.押腳連接片(左)	10.下切刀片	11.下切刀夾板	12.押具輔助座彈簧	13.押具輔助座	14.押具押板(左)-短	15.押具押板(右)-短	16.押具押板(左)-長	17.押具押板(右)-長	18.彈簧固定座	19.切角防護片	20.切角防護片彈簧	21.墊塊	22.綠色毛線	23.導布板	24.勾針驅動槓桿	25.驅動連桿	
460	FW-740TA-460-01	07400616	07400617	07400618	07400620	07400621	07400623	07400624-460MF	07400626	07400627	07400629	07400630	07400632	07400633	07400635A	07400636A	07401924	07401925	07400638	07400639	07400640	07400649	07400651	x	x	x	
	FW-740TA-460-02	"	"	"	"	"	"	"	"	"	"	"	"	07401821	07401824	07401825	07401914	07401915	"	07401828	"	"	"	07401822	x	x	
	FW-740TA-460-02R	"	"	"	"	"	"	"	"	"	"	"	"	07402116	"	"	"	"	"	"	"	"	"	"	x	x	
	FW-740TA-460-02H	"	"	"	"	"	"	"	"	"	07402617	"	"	07401821	07402624	07402625	07402624	07402625	"	"	"	"	"	"	x	x	
	FW-740TA-460-02H(特厚寬刀)	"	"	"	"	"	"	"	"	"	"	"	"	07401821	07402651	07402652	07402651	07402652	"	"	"	"	"	"	x	x	
	FW-740TA-460-02H(特厚窄刀)	"	"	"	"	"	"	"	"	"	07400629	"	"	07401821	"	"	"	"	"	"	"	"	"	"	"	x	x
	FW-740TA-460-02RH	"	"	"	"	"	"	"	"	"	07402617	"	"	07402116	07402624	07402625	07402624	07402625	"	"	"	"	"	"	x	x	
	FW-740TA-460-01-T2	x	x	x	x	x	x	x	"	"	07400629	"	"	07400633	07402219	07402220	07402219	07402220	"	07402216	"	x	"	x	x	x	x
	FW-740TA-460-02-T2	x	x	x	x	x	x	x	"	"	"	"	"	07401821	07402819	07402820	07402819	07402820	"	"	"	x	"	07401822	x	x	x
	FW-740TA-460-02R-T2	x	x	x	x	x	x	x	"	"	"	"	"	07402116	"	"	"	"	"	"	"	x	"	"	x	x	x
	FW-740TA-460-02H-T2	x	x	x	x	x	x	x	"	"	07402617	"	"	07401821	"	"	"	"	"	"	"	x	"	"	x	x	x
	FW-740TA-460-T4	07400616	07400617	07400618	07400620	07400621	07400623	07400624-460MF	"	"	x	x	x	x	x	x	x	x	x	x	x	x	x	"	x	x	x
	FW-740TA-460-01-T5	"	"	"	"	"	"	"	"	"	07400629	07400630	07400632	07404333	x	x	x	x	x	x	07401828	07400640	07400649	"	x	x	x
	FW-740TA-460-01-S	"	"	"	"	"	"	"	"	"	"	07402302	"	07400633	07400635A	07400636A	07401924	07401925	07400638	07400639	"	"	"	x	x	x	x
	FW-740TA-460-02-S	"	"	"	"	"	"	"	"	"	"	07400630	"	07401821	07401824	07401825	07401914	07401915	"	07401828	"	"	"	07401822	x	x	x
	FW-740TA-460-01-DS	"	"	"	"	"	"	"	"	"	"	"	"	07400633	07400635A	07400636A	07401924	07401925	"	07400639	"	"	"	x	x	x	x
FW-740TA-460-02-4L10	"	"	"	"	"	"	07403512	"	07403515	"	"	"	07403521	07403524	07403525	07403524	07403525	"	07403528	"	x	"	07403556	x	x	x	
FW-740TA-460-02-4L15	"	"	"	"	"	"	"	"	"	"	"	"	07403521	"	"	"	"	"	"	"	x	"	"	"	x	x	x
FW-740TA-460-02-4L20	"	"	"	"	"	"	"	"	"	"	"	"	07403565	07403566	07403567	07403566	07403567	"	"	"	x	"	"	x	x	x	
464	FW-740TA-464-01	07400616	07400617	07400618	07400620	07400621	07400623	07400624-460MF	07400626	07400627	07400629	07400630	07400632	07400633	07400635A	07400636A	07401924	07401925	07400638	07400639	07400640	07400649	07400651	x	x	x	
	FW-740TA-464-02	"	"	"	"	"	"	"	"	"	"	"	"	07401821	07401824	07401825	07401914	07401915	"	07401828	"	"	"	07401822	x	x	
	FW-740TA-464-02R	"	"	"	"	"	"	"	"	"	"	"	"	07402116	"	"	"	"	"	"	"	"	"	"	x	x	
470	FW-740TA-470-01-DS	07400616	07400617	07400618	x	07400621	07400623	07403410	07400626	07400627	07400629	07400630	07400632	07402116	07403412	07403431	07403412	07403431	07400638	07400639	07400640	07400649	07400651	x	07403418	07403445	
480	FW-740TA-480-01-DS	07400616	07400617	07400618	x	07400621	07400623	07403422	07400626	07400627	07400629	07400630	07400632	07402116	07403412	07403431	07403412	07403431	07400638	07400639	07400640	07400649	07400651	x	07403450	07403445	
	FW-740TA-480-T4	"	"	"	x	"	"	"	"	"	x	x	x	x	x	x	x	x	x	x	x	x	"	x	"	"	
356	FW-740TA-356-01	07400616	07400617	07400618	07400620	07400621	07400623	07400624-460MF	07400626	07400627	07400629	07400630	07400632	07400633	07400635A	07400636A	07401924	07401925	07400638	07400639	07400640	07400649	07400651	x	x	x	
	FW-740TA-356-02	"	"	"	"	"	"	"	"	"	"	"	"	07401821	07401824	07401825	07401914	07401915	"	07401828	"	"	"	07401822	x	x	
560	FW-740TA-560-01	07400616	07400617	07400618	07400620	07400621	07400623	07400624-460MF	07400626	07400627	07400629	07400630	07400632	07400633	07400635A	07400636A	07401924	07401925	07400638	07400639	07400640	07400649	07400651	x	x	x	
	FW-740TA-560-02	"	"	"	"	"	"	"	"	"	"	"	"	07401821	07401824	07401825	07401914	07401915	"	07401828	"	"	"	07401822	x	x	
564	FW-740TA-564-01	07400616	07400617	07400618	07400620	07400621	07400623	07400624-460MF	07400626	07400627	07400629	07400630	07400632	07400633	07400635A	07400636A	07401924	07401925	07400638	07400639	07400640	07400649	07400651	x	x	x	
	FW-740TA-564-02	"	"	"	"	"	"	"	"	"	"	"	"	07401821	07401824	07401825	07401914	07401915	"	07401828	"	"	"	07401822	x	x	
580	FW-740TA-580-01	07400616	07400617	07400618	x	07400621	07400623	07403422	07400626	07400627	07400629	07400630	07400632	07402116	07403412	07403431	07403412	07403431	07400638	07400639	07400640	07400649	07400651	x	07403450	07403445	

- 【押具整組】：包含 1 ~ 25 的零件，下單時請特別注意，避免重複訂購。
- 產品使用注意事項：當原使用產品的規格，欲變更其他規格；例如：4針5.2mm變更為4針6.0mm，必須使用校車定規組由專業技師調校。

(V 為選擇配備)

附件1

針具規格	Main Parts Models																														
		押具整組	真針	假針	針鑷	針鑷組	針板組	針板	針板舌	後送齒	前送齒	針檔(後)	導布器	導布器座	導布器彈簧片	導布器滑軌(左)	導布器滑軌(右)	下巴蓋板	上蓋	上刀片支架	上刀片	上切刀固定座	導布蓋	控制架	織帶喇叭組	貼條喇叭組	T.T反打結調送料機(含控制箱)	AW1吸風組	AW2箱型吸風組		
		FW-740TA-460-01	FW-740TA-460-02	FW-740TA-460-02R	FW-740TA-460-02H	FW-740TA-460-02H(特厚寬刀)	FW-740TA-460-02H(特厚窄刀)	FW-740TA-460-02RH	FW-740TA-460-01-T2	FW-740TA-460-02-T2	FW-740TA-460-02R-T2	FW-740TA-460-02H-T2	FW-740TA-460-T4	FW-740TA-460-01-T5	FW-740TA-460-01-S	FW-740TA-460-02-S	FW-740TA-460-01-DS	FW-740TA-460-02-4L10	FW-740TA-460-02-4L15	FW-740TA-460-02-4L20	FW-740TA-464-01	FW-740TA-464-02	FW-740TA-464-02R	FW-740TA-470-01-DS	FW-740TA-480-01-DS	FW-740TA-480-T4	FW-740TA-356-01	FW-740TA-356-02	FW-740TA-560-01	FW-740TA-560-02	FW-740TA-564-01
460	07400613-460	07400541-452	07400542-452	07400540-460	07400531-460	07400532A-460	07400544A-460	0740546-460	07401008	07401007	07401010	x	x	x	x	x	x	07400216	07400742	07400744	07400745	07400145	07400167A	x	x	x	V	V			
	07401801-460	"	"	"	"	07401852A-460	07401842A-460	"	07401841	"	"	07401831	07401834	07401835	07401836	07401837	07401839	x	"	"	"	"	"	x	x	x	V	V			
	07402501-460	"	"	"	"	07400532A-460	07400544A-460	"	07401008	"	"	"	"	"	"	"	"	x	"	"	"	"	"	x	x	x	V	V			
	07402601-460	"	"	"	"	07401852A-460	07401842A-460	"	07401841	"	"	07402631	"	"	"	"	"	x	07402636	07402637	07402638	"	"	x	x	x	V	V			
	07404001-460	"	"	"	"	"	"	"	"	"	"	"	"	"	"	"	"	x	"	"	"	"	"	x	x	x	V	V			
	07404002-460	"	"	"	"	"	"	"	"	"	"	"	"	"	"	"	"	x	"	"	"	"	"	x	x	x	V	V			
	07402701-460	"	"	"	"	07400532A-460	07400544A-460	"	07401008	"	"	"	"	"	"	"	"	x	"	"	"	"	"	x	x	x	V	V			
	07402218-460	07402240-452	"	"	"	"	"	"	"	"	"	x	x	x	x	x	x	07400216	07400742	07400744	07400745	07402212	"	x	V	x	V	V			
	07402818-460	"	"	"	"	07401852A-460	07401842A-460	"	07401841	"	"	07401831	07401834	07401835	07401836	07401837	07401839	x	"	"	"	"	"	x	V	x	V	V			
	07404005-460	"	"	"	"	07400532A-460	07400544A-460	"	07401008	"	"	"	"	"	"	"	"	x	"	"	"	"	"	x	V	x	V	V			
	07404006-460	"	"	"	"	07401852A-460	07401842A-460	"	07401841	"	"	07402631	"	"	"	"	"	x	07402636	07402637	07402638	"	"	x	V	x	V	V			
	07403915-460	07400541-452	"	"	"	07403975-460	07403912-460	"	07401008	07403974	"	x	x	x	x	x	x	07403918	x	x	x	07400145	07403917	x	x	V	V	V			
	07404338-460	"	"	"	"	07400532A-460	07400544A-460	"	"	07401007	"	x	x	x	x	x	x	07400216	07400742	07400744	07400745	"	07400167A	x	x	x	V	V			
	07402306-460	"	"	"	"	"	"	"	"	"	"	x	x	x	x	x	x	07400216	"	"	"	"	"	x	x	x	V	V			
	07402307-460	"	"	"	"	07401852A-460	07401842A-460	"	07401841	"	"	07401831	07401834	07401835	07401836	07401837	07401839	x	"	"	"	"	"	x	x	x	V	V			
	07402408-460	07402405-452	07402506-452	"	"	07400532A-460	07400544A-460	"	07402403	07402407	"	x	x	x	x	x	x	07400216	"	"	"	"	"	x	x	x	V	V			
07403501-460	07400541-452	07400542-452	"	"	07403545-460	07403546-460	"	07403544-4L10	07403543-4L10	"	07403531	07403534	07401835	07401836	07401837	07401839	x	"	"	"	07403551	"	x	x	x	V	V				
07403580-460	"	"	"	"	07403576-460	07403578-460	"	07403544-4L15	07403543-4L15	"	"	"	"	"	"	"	x	"	"	"	"	"	"	x	x	x	V	V			
07403581-460	"	"	"	"	07403577-460	07403579-460	"	07403544-4L20	07403543-4L20	"	"	"	"	"	"	"	x	"	"	"	"	"	"	x	x	x	V	V			
464	07400613-464	07400541-452	07400542-452	07400540-464	07400531-464	07400532A-464	07400544A-464	0740546-464	07401008	07401007	07401010	x	x	x	x	x	x	07400216	07400742	07400744	07400745	07400145	07400167A	x	x	x	V	V			
	07401801-464	"	"	"	"	07401852A-464	07401842A-464	"	07401841	"	"	07401831	07401834	07401835	07401836	07401837	07401839	x	"	"	"	"	"	x	x	x	V	V			
	07402501-464	"	"	"	"	07400532A-464	07400544A-464	"	07401008	"	"	"	"	"	"	"	"	x	"	"	"	"	"	x	x	x	V	V			
470	07403408-470	07403405-470	x	07400540-470	07400531-470	07400532A-470	07400544A-470	0740546-470	07403403	07402407	07403404	x	x	x	x	x	x	07400216	07400742	07400744	07400745	07400145	07400167A	x	x	x	V	V			
	07403408-480	07403405-470	x	07400540-480	07400531-480	07400532A-480	07400544A-480	0740546-480	07403403	07402407	07403404	x	x	x	x	x	x	07400216	07400742	07400744	07400745	07400145	07400167A	x	x	x	V	V			
480	07403915-480	"	x	"	"	07403975-480	07403912-480	"	07401008	07403913	07401010	x	x	x	x	x	x	07403918	x	x	x	"	07403917	x	x	V	V	V			
	07403915-480	"	x	"	"	07403975-480	07403912-480	"	07401008	07403913	07401010	x	x	x	x	x	x	07403918	x	x	x	"	07403917	x	x	V	V	V			
356	07400613-460	07400541-452	07400542-452	07400540-356	07400531-356	07400532A-356	07400544A-460	07400546-356	07401008	07401007	07401010	x	x	x	x	x	x	07400216	07400742	07400744	07400745	07400145	07400167A	x	x	x	V	V			
	07401801-460	"	"	"	"	07401852A-356	07401842A-460	"	07401841	"	"	07401831	07401834	07401835	07401836	07401837	07401839	x	"	"	"	"	"	x	x	x	V	V			
560	07400613-460	07400541-452	07400542-452	07400540-560	07400531-560	07400532A-560	07400544A-460	0740546-560	07401008	07401007	07401010	x	x	x	x	x	x	07400216	07400742	07400744	07400745	07400145	07400167A	x	x	x	V	V			
	07401801-460	"	"	"	"	07401852A-560	07401842A-460	"	07401841	"	"	07401831	07401834	07401835	07401836	07401837	07401839	x	"	"	"	"	"	x	x	x	V	V			
564	07400613-464	07400541-452	07400542-452	07400540-564	07400531-564	07400532A-564	07400544A-464	0740546-564	07401008	07401007	07401010	x	x	x	x	x	x	07400216	07400742	07400744	07400745	07400145	07400167A	x	x	x	V	V			
	07401801-464	"	"	"	"	07401852A-564	07401842A-464	"	07401841	"	"	07401831	07401834	07401835	07401836	07401837	07401839	x	"	"	"	"	"	x	x	x	V	V			
580	07403408-480	07403405-470	x	07400540-580	07400531-580	07400532A-580	07400544A-480	0740546-580	07403403	07402407	07403404	x	x	x	x	x	x	07400216	07400742	07400744	07400745	07400145	07400167A	x	x	x	V	V			

- 【押具整組】：包含 1 ~ 25 的零件，下單時請特別注意，避免重複訂購。
- 產品使用注意事項：當原使用產品的規格，欲變更其他規格；例如：4針5.2mm變更為4針6.0mm，必須使用校車定規組由專業技師調校。

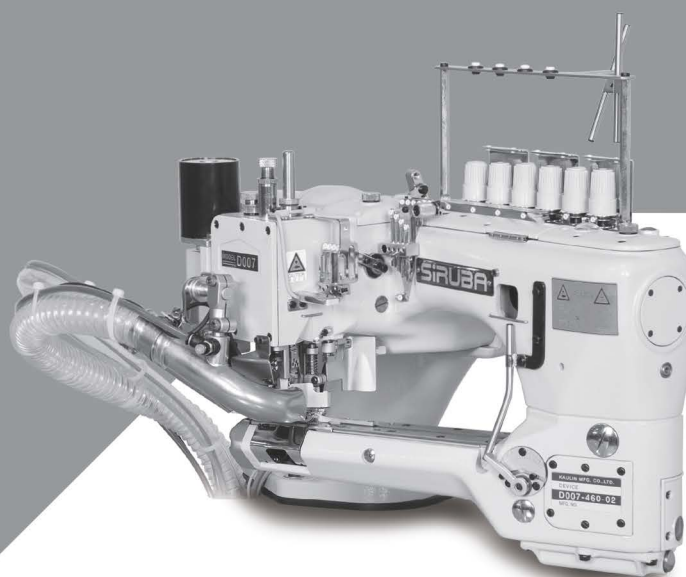

 高林股份有限公司
KAULIN MFG. CO., LTD.

由於對產品的改良及更新，本產品使用說明書中與零件圖之產品及外觀的修改恕不事先通知！
The specification and/or appearances of the equipment described in this instruction book & parts list are subject to change because of modification which will without previous notice.
D007R(B).JUL.2018